





Index

1- System description	6
1.1- Warnings.....	6
1.2- Introduction	6
1.3.- Principle of operation	6
1.4.- Characteristics	7
1.5.- Composition of the control panel	7
1.6. – Loop Elements Capacity	8
1.6.1.- Addressable sensors.....	10
1.6.1.1.- Addressable smoke sensors (A30XHA & A30XHA-S).....	10
1.6.1.2.- Addressable temperature sensor (A30XTA)	11
1.6.1.3.- Addressable multi-sensor (A30XHTCO).....	12
1.6.1.4- Addressable Smoke-Heat and CO sensors with Isolator (A50SHCOI)	14
1.6.1.5 Smoke-Heat addressable sensors with/without isolator (A50SHI / A50SH).....	15
1.6.1.6- Smoke addressable sensors with/without isolator (A50SI / A50S).....	16
1.6.1.7- Heat addressable sensors with/without isolator (A50HI / A50H)	17
1.6.2.- Addressable alarm Manual Call Point (PUCAY)	19
1.6.3. - Modules	20
1.6.3.1- Master detection module (KMAY)	20
1.6.3.2- Technical signals module (MSTAY).....	21
1.6.3.3- Master relay and technical signals module (MYOA)	22
1.6.3.4- Master relays module (MDA1Y)	23
1.6.3.5- Master relay module (MDA2Y).....	23
1.6.3.6 –Two relay dry contact output module (MDA2YLT)	25
1.6.3.7-Module to connect 32 detectors / 10 manual call points (KMAY32)	26
1.6.3.8 –Module with 8 inputs (MSTAY8)	27
1.6.3.9- Loop isolator (KABY).....	29
1.6.3.10- Addressable sounder (SIRAY / SIRAYL / SIRAY+BSLC)	30
1.6.3.11- Remote indicator (PIAL).....	31
1.6.3.12-Base with siren and visual alarm (A50ZSLDR / A50ZSDDR).....	32
1.6.3.13-Base with siren and visual alarm (A30XZSLDR / A30XZSDDR)	34
1.6.3.14- A50 family detectors with Light and sound integrated (A50xxLD/A50xxD/A50xxL)	36
1.6.4- Repeaters	39
1.6.4.1- Installation	39
1.6.4.2. Operation and Configuration	40
1.6.4.3.- Repeater menus	42
1.6.5- Control panel network	44
1.6.5.1- Installation	44
1.6.5.2- Operation and configuration.....	45
1.6.5.3- Control panels network menu.....	46
1.7- Accessories.....	46
1.7.1- PC based configuration software.....	46
2- Installation.....	47
2.1- Control panel installation.....	47
2.2- Onix/Quartz system connection.....	48
2.2.1- Electrical supply	49
2.2.2- Loop driver/ CPU LOGIC BOARD	50
2.2.3- Output card	50
2.3- Components.....	51
2.3.1- Batteries.....	51
2.3.2- Connection schematic of a typical loop.....	51
2.3.3- Sounder and controls with relays.....	53
2.3.3.1- Connection of the internal two tone 24V Sounder (SIR-24B / SIR-24BL).....	53
2.3.3.2- Connection of the non-flashing internal 24V Sounder (SIR24P).....	53
2.3.3.3- Connection of the flashing internal 24V Sounder (SIR24F)	54

2.3.3.4.- External Siren 24V alarm box (CAEC).....	54
2.4- Accessories.....	55
2.4.1.- Computer.....	55
3- Operation and configuration.....	57
3.1- Description of the front panel.....	57
3.1.1- Keypad.....	57
3.1.2.- Light indicators.....	57
3.1.3- LCD.....	58
3.2- Access levels.....	58
3.2.1.- Level 1 access.....	62
3.2.1.1.- Activation of the control panel.....	62
3.2.1.2. Incident and anomaly display.....	63
3.2.1.3- Moving through incidents.....	65
3.2.1.4- Look up incidents.....	66
3.2.1.5.- Silence buzzer.....	66
3.2.2. - Level 2 access.....	66
3.2.2.1. - Access code.....	66
3.2.2.2- Front panel keypad.....	66
3.2.2.3- Reset events.....	66
3.2.2.4.- Monitor.....	67
3.2.2.5.- Activate / Deactivate logical relays.....	67
3.2.2.6.- Activate / Deactivate general relays.....	67
3.2.2.7.- System configuration.....	68
3.2.2.8.- Enable/ Disable elements and zones.....	68
3.2.2.9- System test.....	68
3.2.2.10.- Welcome message.....	69
3.2.2.11. - General reset/rearm.....	69
3.2.2.12. - Review history.....	69
3.2.3- Level 3 access.....	70
3.2.3.1- Access code.....	70
3.2.3.2.- Label points.....	71
3.2.3.3.- Configure.....	71
3.2.3.3.1. - Loop configuration.....	71
3.2.3.3.2- Logic In/out configuration.....	72
3.2.3.3.2.1- Configure logical relays.....	73
3.2.3.3.2.2.- Relay Auto. Configuration.....	75
3.2.3.3.2.3.- Delete Configured Relays.....	75
3.2.3.3.3.- Configure alarm zones.....	75
3.2.3.3.4.- Configure element sensitivity.....	76
3.2.3.3.5.- Additional passwords.....	76
3.2.3.3.6.- Configure auto-evacuation.....	76
3.2.3.3.7- Added Delay Setup.....	77
3.2.3.3.8- Fast Trigger Zone.....	77
3.2.3.3.9- Send Zones to Repeaters.....	77
3.2.3.4- Update date and time.....	77
3.2.3.5.- Day/ Night timetable.....	77
3.2.3.6.- Put into test/ normal mode.....	78
3.2.3.7- Led ON / OFF.....	78
3.2.3.8.- Language menu.....	78
3.2.3.9.- Communications.....	79
3.2.3.10.- Stop Sounder Function.....	81
4- Set-up.....	82
4.1- Prior verifications.....	82
4.2- Supply.....	83
4.3- Loops and relays.....	83
4.4- Faults.....	84
Annex 1: Use of the Control Panel RUBI / QUARTZ / ONIX System.....	89

1. What is a control panel RUBI / QUARTZ / ONIX?.....	89
2. Front panel of the system.....	89
3. What happens if the buzzer sounds?.....	89
4. Checking the incident	89
5. Evacuation	90
6. SILENCE SIRENS	90
7. RESET EVENTS	90
Annex 2: Elements configuration RUBI / QUARTZ / ONIX	91
1. Introduction.....	91
2. Keypad access.....	92
3. Configuration of points in a loop	93
3.1. System Programming.....	93
3.2. Configure	93
3.3-Configure Loop.....	94
3.4.-Loop Configuration	94
3.5.-Assign a number to Point.....	95
4.-Programming verification process.....	95
5. -Configure Zones	96
6.-Replacing a loop element	96

CERTIFICATION

   <p>2821</p>	
 <p>C/ Compositor Wagner,8 —P.I. Can Jardí CP 08191-- Rubí, Barcelona (España)</p> <p>2821-CPR-0377 25</p>	
<p>EN 54-2</p> <p>Equipo de control e indicación para sistemas de detección y alarma de incendios de edificios <i>Control and indicating equipment for fire detection and alarm systems in buildings</i></p> <p>“ONIX/QUARTZ”</p>	<p>EN 54-4</p> <p>Equipo de suministro de alimentación para sistemas de detección y alarma de incendios de edificios <i>Power supply equipment for fire detection and alarm systems in buildings</i></p> <p>“ONIX/QUARTZ”</p>
<p>Comportamiento frente a incendios <i>Performance under fire condition</i></p> <p style="text-align: right;">Cumple/ Passed</p>	<p>Comportamiento de suministro de alimentación/ <i>Performances of Power Supply</i></p> <p style="text-align: right;">Cumple/ Passed</p>
<p>Intervalo de respuesta (tiempo de respuesta al fuego) <i>Response delay (response time to fire)</i></p> <p style="text-align: right;">Cumple/ Passed</p>	<p>Fiabilidad en el funcionamiento/ <i>Operational reliability</i></p> <p style="text-align: right;">Cumple/ Passed</p>
<p>Seguridad Operacional <i>Operational reliability</i></p> <p style="text-align: right;">Cumple/ Passed</p>	<p>Duración de la seguridad operacional y retardo a la respuesta; resistencia a la temperatura <i>Durability of operational reliability, Temperature resistance</i></p> <p style="text-align: right;">Cumple/ Passed</p>
<p>Duración de la seguridad operacional y retardo a la respuesta; resistencia a la vibración <i>Durability of operational reliability, Vibration resistance</i></p> <p style="text-align: right;">Cumple/ Passed</p>	<p>Duración de la seguridad operacional y retardo a la respuesta; resistencia a la vibración <i>Durability of operational reliability Vibration resistance</i></p> <p style="text-align: right;">Cumple/ Passed</p>
<p>Duración de la seguridad operacional y retardo a la respuesta; estabilidad eléctrica <i>Durability of operational reliability: electrical stability</i></p> <p style="text-align: right;">Cumple/ Passed</p>	<p>Duración de la seguridad operacional y retardo a la respuesta; estabilidad eléctrica <i>Durability of operational reliability: electrical stability</i></p> <p style="text-align: right;">Cumple/ Passed</p>
<p>Duración de la seguridad operacional y retardo a la respuesta; resistencia a la humedad <i>Durability of operational reliability: humidity resistance</i></p> <p style="text-align: right;">Cumple/ Passed</p>	<p>Duración de la seguridad operacional y retardo a la respuesta; resistencia a la humedad <i>Durability of operational reliability: humidity resistance</i></p> <p style="text-align: right;">Cumple/ Passed</p>
<p>Salida a dispositivos de alarma de incendio <i>Output to fire alarm devices</i></p> <p style="text-align: right;">Cumple/ Passed</p>	
<p>Retardo de salidas <i>Delay to outputs</i></p> <p style="text-align: right;">Cumple/ Passed</p>	
<p>Contador de alarmas <i>Alarm counter</i></p> <p style="text-align: right;">Cumple/ Passed</p>	
<p>Señales de avería de puntos <i>Fault Signal from points</i></p> <p style="text-align: right;">Cumple/ Passed</p>	
<p>Estado de prueba <i>Test condition</i></p> <p style="text-align: right;">Cumple/ Passed</p>	

1- System description

Onix/Quartz control panels are supplied with the following material:

- 2 end of line resistances 4K7 2W 5%
- 2 diodes DBY252
- 4 fuses: 1 A, 2 A, 4 A y 8 A.

1.1- Warnings



All equipments described in this manual are professional equipments. They must be used and handle ONLY by trained and skilled professionals under the national or local specific laws.



All equipments described in this manual must be installed in the specified ambient conditions covering the requirements of the equipments and the national or local laws.

1.2- Introduction

The Digital Fire detection Control Panel **Onix/Quartz** is EN54-2 and EN 54-4 standard certified according to the latest CE directives and can successfully overcome difficult environmental conditions, electrical interference, electromagnetic radiate upsets, vibrations, etc.

The **Digital Detection System** represents the most modern technology in fire detection and constitutes a natural evolution from the Identifiable Detection System towards equipment that not only is able to identify the element that produces the alarm (detector or button), but that also allows for the total configuration of detection parameters (alarm levels, sensitivity,...) as well as the adaptation of the set-up to the environmental conditions and the dirtiness of the sensor.

In the Cofem Digital Detection System, the loop elements (sensors, manual call points, relay modules, masters, addressable sounders and technical indicator modules) are auto-identifiable, in other words, all of them can be installed with no need for prior manual encoding, facilitating enormously the assembly of and subsequent modifications to the installation.

1.3.- Principle of operation

The **Digital Detection System** is based on the measurement and transmission of the instant value of the monitored magnitude (smoke, temperature or monoxide concentration), for their subsequent processing in the control panel, which will consider the alert or standby status of the sensor.

The temperature, the smoke concentration and the amount of monoxide are sent through the corresponding sensor in electrical voltages related to the measured magnitude.

After an adaptation process, an optimal relationship between the measured magnitude and the electrical voltage is obtained.

Each sensor incorporates a microprocessor responsible for the digitisation of the analogue value read in the sensor, for transmission of this value to the control panel and for identification of the sensor.

The main difference between the conventional and addressable detection systems lies in that for the former the voltage delivered by the transducer is compared with a predetermined and fixed threshold (V_{alarm}), obtaining from that comparison the *system in standby* or *system in alarm* status.

In the digital (addressable) detection system, on the contrary, the value given by the transducer is constantly recorded and processed, being possible to act on the detection parameters, as well as, for example, the alarm threshold.

With this type of system, not only we can vary the sensitivity of the sensor, but we can even adapt the sensitivity to the environmental conditions.

Each sensor on the Cofem Digital Detection System transmits its digital value to the control panel with a regularity of less than 10 seconds. The control panel gathers the readings from each sensor and determines the status thereof according to these instant readings, any previous readings (history), the pre-programmed parameters and on the decision algorithm.

Note: Within the detection and fire alarm systems, there are 2 different technologies. In the CONVENTIONAL SYSTEM, the detector or the alarm call point is causing alarm in the control panel. In the ADDRESSABLE SYSTEM, the sensor, the alarm call point or the module, is the device which communicates the value of reading or state to the control panel, and this one processes the alarm state

1.4.- Characteristics

- Base Control Panel of 1 or 2 loops.
- Allows 226 connection elements per loop in Onix / 99 elements per loop in Quartz.
- All the loop elements are monitored, except the **KABY** loop isolator.
- Capacity for up to 128 configurable relays (64 per loop) in Onix / 64 relays (32 per loop) in Quartz.
- Enables programming of 99 zones.
- Memory stores up to 6460 events with date and time.
- Monitored delayable general siren output identified as **S1** and **S2** (Sounder).
- Voltage-free non-monitored alarm output identified as **ALARM**.
- Non-monitored delayable free voltage general failure output identified as **FAULT**.
- Evacuation button.
- Backlit LCD display of 4 lines and 40 characters.
- Incorporates Spanish, English, French, Portuguese, etc.
- Configurable and manageable through I-Link PC software.
- Allows connection of up to 15 repeaters and 15 control panels in network.
- MODBUS (See specific manual of this functionality).
- Cofem Remote on demand.
- CRI functionality on demand.
- Size: 363 x331 x 96 mm
- IP30.
- Certified and CE mark according to EN 54-2 and EN 54-4 Standards.
- For indoor use only

1.5.- Composition of the control panel

- Backlit LCD display of 4 lines and 40 characters.
- Keyboard made up of 13 keys that form two groups; one where the menu handling keys can be found and the other where specific control panel functions may be performed.
- 15 LEDs that enable quick viewing of the control panel status (Supply, Mode of operation, Alarms and Failures).
- Communications port: RS485 and USB 2.0.
- Power supply: independent module responsible for controlling the Voltage of the primary 30V supply that supplies the other boards. There are inside: protection fuses, 30 V output, battery connection terminals, relay outputs:
 - **S1 & S2** : Sounder: delayable monitored relay.
 - **Alarm** : Voltage-free relay.
 - **Failure** : Monitored free voltage delayable relay
- Multitasking CPU: within the CPU there are a loop controller, a power controller, two-loop driver, communication port 485 and USB 2.0 compatible.

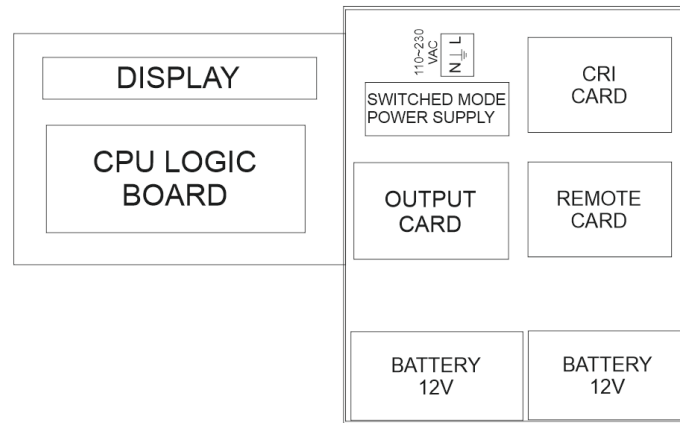

Figure 1. Layout of circuits in the control panel

1.6. – Loop Elements Capacity

The number of devices that it is possible to connect to the loop is calculated of precise form by the software of loop elements capacity calculation.

NOTE: To define the loop, It must be taking into account the limitations established in the installation standards that apply to the premises or building, such as maximum coverage, type of cable (fire-resistant or non-fire-resistant), the installation of short-circuit isolators between zones and functions of the diferent type elements of the loop, etc.

The cable material for the table is Cu with $41 \Omega \cdot \text{mm}^2/\text{Km}$, as it is stated in the corresponding note.

INSTALLATION EXAMPLE

An installation requires 136 A50XHAS sensors, 17 PUCAY manual call points and 18 addressable sounders SIRAY with standard sound level.

It is known that installation requires 1 loop cable of 500 m with $2 \times 1,5 \text{ mm}^2$ section, where the nearest device to control panel is 50 m.

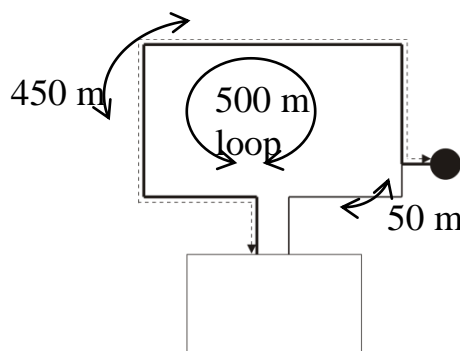

To do this, you must enter the information of the Alarm Control Panel model, cable length, cable section, arrangement of elements in the cable and devices of the loop.

The element layout option in the loop supports **two possibilities**; "**distributed**" refers to the fact that the elements are distributed along the cable that is in a closed loop. It offers a fast and transparent way to calculate general closed-loop operating situations; "**point**" refers to the calculation in open line with all the elements located at the end of the cable length defined in the program. It allows the calculation of distribution situations of complex elements or open-line operation.

LOOP ELEMENTS CAPACITY CALCULATION
CÁLCULO DE CAPACIDAD DE ELEMENTOS DEL BUCLE

GENERAL DATA/ DATOS GENERALES

Control Panel Model/Modelo Central =

Wire length /Longitud del cable = m

Cable section/Sección del cable = mm²

Elements Arrangement in wire / Disposición Elementos en cable =

LOOP ELEMENTS DATA/ DATOS ELEMENTOS BUCLE

Nº Elements/ Nº Equipos	Model / Modelo	Sound dB/ Sonido dB	Power Light/ Potencia Luz
17	PUCAY		
0	KIMAY		
0	KMAY32		
0	MSTAY		
0	MSTAY8		
0	MDA1Y		
0	MDA2Y		
0	MDA2YLT		
0	MYOA		
136	A30XHA/A30XHAS/ A30XTA/A30XHTCO		
0	KABY		
18	SIRAY	Standard	
0	SIRAYL	Standard	
0	(SIRAY + BSLC)	Standard	Standard
0	A30XBLSL		Standard
0	A30XBSD	Standard	

RESULTS/ RESULTADOS

LOOP LOAD/ CARGA DEL BUCLE =	72,73%
Nº Elements / Nº Elementos =	171
Nº Relays/ Nº Relés =	18

The figure shows the result of the previous calculation example for a distributed element arrangement (note: the cable length corresponds to that of the 500m loop).

The result shows that it supports this configuration perfectly. Red color informs that system capacity is exceeded.

1.6.1.- Addressable sensors

1.6.1.1.- Addressable smoke sensors (A30XHA & A30XHA-S)

The addressable smoke sensors measure the smoke particle concentration by unit of volume present in the atmosphere. If we designate by Y an un-dimensioned parameter proportional to the smoke concentration, then Y will have to be close to zero, and will be growing as the atmosphere is contaminated.

The implemented dynamic processing algorithms in the control panel, use the Y_{alarm} value as level for setting off the Alarm. This preset level is at:

$$Y_{\text{alarm}} = 40$$

This level can be manually modified from the control panel.

When the concentration of smoke exceeds the **Alarm Level**

(the average must exceed Y_{alarm}) the alarm for the sensor is activated.

Through the control panel, a level Y_{dirty} (20) is set and when this is exceeded the system warns us of the need to replace or repair the sensor.

The Optical Smoke Sensor is based on the Tyndall effect created in an optical chamber. The variation of the electrical characteristics in the presence of combustion aerosols makes it suitable as a smoke sensor.

The sensor element is formed by an optical chamber provided with an infrared emitter and receiver. In the absence of smoke the intensity of infrared caught by the receiver is null, due to the physical labyrinth created between the two. When smoke is present, the infrared reflections from the particles of the same cause the receiver to obtain a certain luminance intensity, (Voltage value proportional to the level of obscuration), all of which is controlled by the microprocessor system.

This sensor has a thermistor, acting as a temperature sensor, triggering at 60°C, considerably augmenting its response to fire.

An optical smoke sensor without a thermal element is also available, with reference **A30XHAS**.

The **A30XHA** and **A30XHA-S** devices are compliant with EN 54-7 with the conformity mark awarded by AENOR. The head and the base (interchangeable throughout the range of sensors) are made in thermal resistant ABS.

The flashing of the red transparent LEDs indicates communication . If the LEDs remain lit they indicate the device is an alarm state.



Sensor A30XHA
(Optical and temperature)



Sensor A30XHAS (optical)

Technical specifications A30XHA and A30XHA-S	
Supply	24 – 35 V any polarity
Standby consumption	1 mA
Alarm consumption	5 mA
Indicator activation	Double red LED
Remote indicator output	Yes
Humidity	20% – 95% RH
Temperature	-10° + 50°C
Sensitivity	According to EN 54-7
IP	IP40

1.6.1.2.- Addressable temperature sensor (A30XTA)

The Addressable Temperature Sensor (A30XTA) measures the room temperature, as well as its rate of change.

When the ambient temperature experiences slow rates of change (less than 1°C / min), the alarm level remains constant to 60°C. However, for fast variations in temperature (above 1 °C/min), the control panel uses an algorithm capable of evaluating the rate of change of temperature, and of adjusting the alarm level to different gradients (*rate of rise detection of temperature*). In this way, a fast variation causes a decrease in the alarm threshold, thereby accelerating the detection.

The chosen degree of sensitivity will depend on the room temperature of the place where each sensor is installed, and in each case the alarm temperature will adapt to the chosen degree.



Sensor A30XTA (temperature)

Also in the detection of temperature confirmation by means of two consecutive readings is used (less than 10 seconds), before activation of the Alarm.

The operation principle is based on the physical properties of an NTC. The variation in electrical characteristics of the thermistor, due to the variation of the room temperature, is what enables its use as a sensor element.

The measurement made by the sensor is converted in a Voltage value, which is digitized and transmitted to the control panel.

The **A30XTA** device complies with EN 54-5 with the mark of conformity with the regulations awarded by AENOR with an A2R sensitivity degree.

The head and the base (interchangeable throughout the range of sensors) are made in thermal resistant ABS.

The flashing of the red transparent LEDs indicates communication . If the LEDs remain lit they indicate the device is an alarm state.

Technical specifications A30XTA	
Supply	24 – 35 V, any polarity
Standby consumption	1 mA
Alarm consumption	5 mA
Indicator activation	Double red LED
Remote indicator output	Yes
Humidity	20% – 95% RH
Temperature	-10° + 50°C
Sensitivity	According to EN 54-5
IP	IP20
Coverage area	52 m ² (subject to local regulation)

1.6.1.3.- Addressable multi-sensor (A30XHTCO)

The addressable multi-sensor **A30XHTCO** has three detection types: monoxide, temperature and smoke.

The addressable multi-sensors is able to measure three types of parameters so the control panel compute the average by means of a dynamic processing algorithm which will vary with the three phenomena.

This processing algorithm will avoid false alarms to a great extent thanks to the incorporation of the monoxide sensor.

The processing algorithm is able to compensate for dirt on the optical camera by combining the measurements of the three different sensors.



Sensor A30XHTCO
(Temperature + optical + monoxide)

The sensor element is formed by an optical chamber provided with an infrared emitter and receiver. In the absence of smoke the intensity of infrared captured by the receiver is null, due to the physical labyrinth created between the two.

When smoke is present, the infrared reflections from the particles of the same cause the receiver to obtain a certain luminance intensity, (Voltage value proportional to the level of obscuration), all of which is controlled by the microprocessor system.

In addition, it has a carbon monoxide sensor with a fast response in the presence of CO which is present in the vast majority of fires.

Finally this sensor has a thermal probe, acting as a thermal sensor, triggering at 60°C, considerably increasing its response to fire.

The **A30XHTCO** sensor complies with EN 54-7 with the conformity mark awarded by AENOR.

The head and the base (interchangeable with all sensors) are made in thermal resistant ABS.

The flashing of the red transparent LEDs indicates communication . If the LEDs remain lit they indicate the device is an alarm state.

Technical specifications A30XHTCO	
Supply	24 – 35 V any polarity
Standby consumption	1 mA
Alarm consumption	5 mA
Indicator activation	Double red LED
Remote indicator output	Yes
Humidity	20% – 95% RH
Temperature	-10° + 50°C
Sensitivity	According to EN 54-7
IP	IP40
Sensor lifespan	10 years
Coverage area	104 m ² (subject to local regulation)

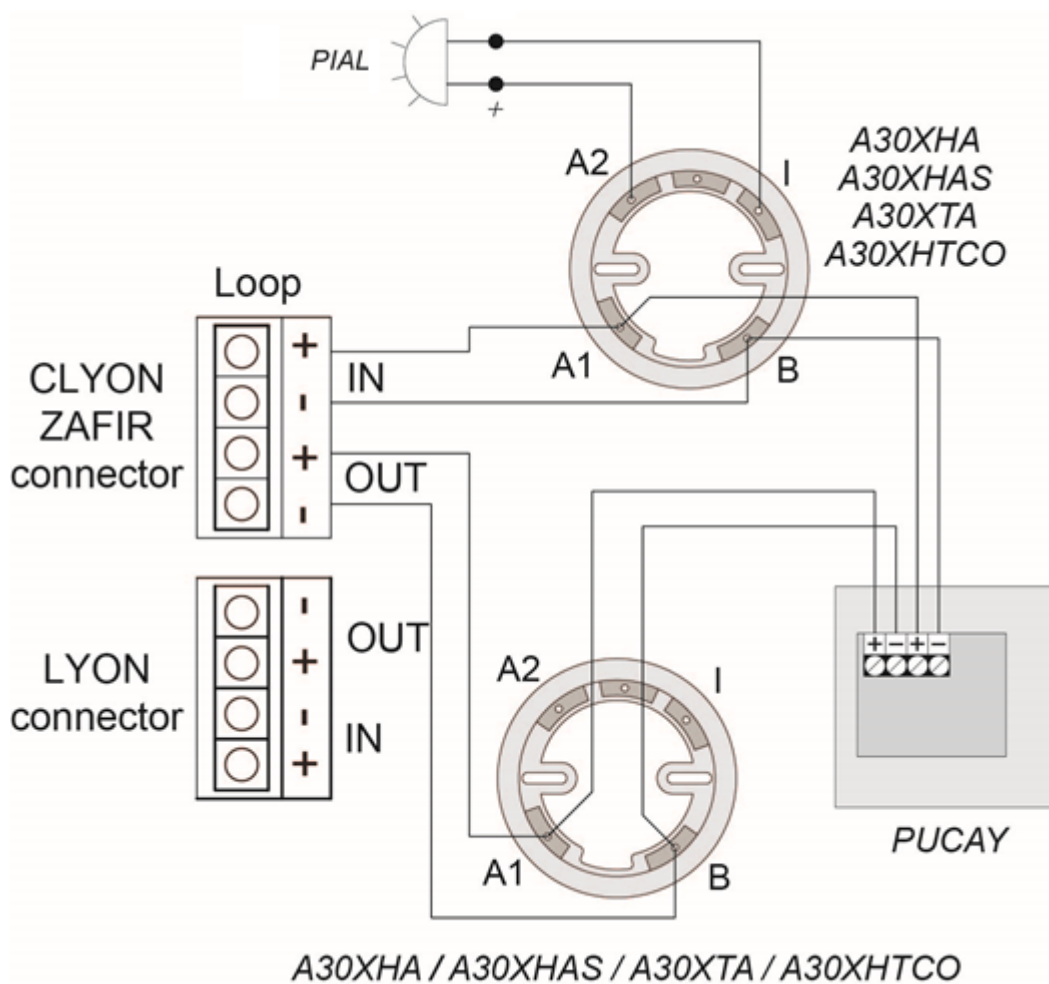

Figure 2. Wiring Diagram of A30XHA, A30XTA, A30XHTCO and PUCAY devices

1.6.1.4- Addressable Smoke-Heat and CO sensors with Isolator (A50SHCOI)

The A50 family of detectors are based on a new refined aesthetic that integrates the latest electronic technology with new, more efficient detection algorithms and a three-dimensional design that makes it more robust against environmental dirt.

The A50 family allows multiple combinations between smoke and heat detection, CO sensor and short-circuit isolator with UL certification.

The A50SHCOI model is a multi-sensor detector that has a short-circuit isolator and three different types of sensors: A smoke sensor, a heat sensor and a Carbon Monoxide (CO) sensor.



Sensor A50SHCOI

The use of the CO sensor is very valuable for the early detection of some types of fire, since the production of this gas is very common, especially in the initial phases of a fire. Its integration with the smoke sensor results in a compact detector that is very robust against false alarms.

To complete its features, a heat sensor with thermovelocimetric response is incorporated, reaching alarm status with a static temperature of 60°C in the case of slow fire developments.

Characteristics:

- Smoke, Heat and CO sensor.
- With short circuit isolator.
- Low profile, total height less than 55 mm (including low base).
- Also available with high base for 20 mm tube.
- Possibility of connection to a remote action indicator.
- Easy connection.
- Bicolor red and yellow LED.
- Indication, by means of the red LED, of the communication with the control panel (single flashing), as well as of the alarm status (LED on).
- Indication, by means of the yellow led (single flash), of the activation of the short-circuit isolator or the lack of communication with the control panel.
- Signaling of the dirty state of the sensor on the control panel display (the sensor allows to differentiate between rapid signal increases due to alarm and small, slow and sustained increases due to the accumulation of dust and dirt).
- Smoke and CO sensor processing algorithm that drastically reduces incidents due to false alarms.
- Easy installation of head and base, interchangeable throughout the A50 family, and made of white heat-resistant ABS.
- UL certified according to Standard EN 54-5 class A2R, EN 54-7 and EN 54 17 with CE marking according to the European Regulation on Construction Products (EU) No. 305/2011.

Technical Specifications - A50SHCOI	
Power supply*	24 – 35 V no polarity *
Standby consumption	0,3 mA
Alarm consumption	2 mA
Activity Indicators	Bicolor LED, red and yellow
Remote indicator output	Yes
Humidity	20 – 95% HR
Temperature	-10° + 50°C
Sensibility	As required by EN 54-5, EN 54-7 y EN 54-17
IP	IP20
CO sensor lifespan	10 years
Coverage area	104 m ² (subject to local regulation)

***NOTE:** The **Isolated** series (**A50SHCOI, A50SHI, A50HI, A50SI,**) have polarity, as the A1 and A2 are positive and B is negative.

1.6.1.5 Smoke-Heat addressable sensors with/without isolator (A50SHI / A50SH)

The A50 family of detectors are based on a new refined aesthetic that integrates the latest electronic technology with new, more efficient detection algorithms and a three-dimensional design that makes it more robust against environmental dirt.

The A50 family allows multiple combinations between smoke and heat detection, CO sensor and short-circuit isolator with UL certification.

The A50HI and A50H models are detectors that have a heat sensor.

The A50HI model additionally incorporates a short circuit isolator.

The heat sensor has thermovelocimetric behavior, reaching alarm status with a static temperature of 60°C in the case of slow fire developments.

Characteristics:

- Heat sensor.
- Model A50HI incorporates short-circuit isolator.
- Low profile, total height less than 42 mm (including low base).
- Also available with high base for 20 mm tube.
- Possibility of connection to a remote action indicator.
- Easy connection (and A50S without polarity).
- Bicolor red and yellow LED.
- Indication, by means of the red LED, of the communication with the control panel (single flashing), as well as of the alarm status (LED on).
- Indication, by means of the yellow led (single flash), of the activation of the short-circuit isolator or the lack of communication with the control panel.
- Easy installation of head and base, interchangeable throughout the A50 series, and made of white heat-resistant ABS.
- UL certificate according to Standard EN 54-5 class A2R with CE marking according to the European Regulation on Construction Products (EU) No. 305/2011. Additionally certified EN 54-17 in the A50HI model.



Sensor A50SHI / A50SH

Technical Specifications - A50SHI / A50SH	
Power supply*	24 – 35 V no polarity*
Standby consumption	0,3 mA
Alarm consumption	2 mA
Activity Indicators	Bicolor LED, red and yellow
Remote indicator output	Yes
Humidity	20 – 95% HR
Temperature	-10° + 50°C
Sensibility	As required by EN 54-5, EN 54-7 (and EN 54-17 A50SHI only)
IP	IP20
Coverage area	104 m ² (subject to local regulation)

***NOTE:** The **Isolated** series (**A50SHCOI, A50SHI, A50HI, A50SI,**) have polarity, as the **A1** and **A2** are positive and **B** is negative.

1.6.1.6- Smoke addressable sensors with/without isolator (A50SI / A50S)

The A50 family of detectors are based on a new refined aesthetic that integrates the latest electronic technology with new, more efficient detection algorithms and a three-dimensional design that makes it more robust against environmental dirt.

The A50 family allows multiple combinations between smoke and heat detection, CO sensor and short-circuit isolator with UL certification.

The A50SI and A50S models are detectors that have a smoke sensor. The A50SI model additionally incorporates a short-circuit isolator.



Sensor A50SI / A50S

The smoke sensor is specially designed to detect the presence of combustion aerosols in a three-dimensional design that makes it more robust against dirt.

Specifications:

- Smoke sensor.
- Model A50SI incorporates short-circuit isolator.
- Low profile, total height less than 42 mm (including low base).
- Also available with high base for 20 mm tube.
- Possibility of connection to a remote action indicator.
- Easy connection (and A50S without polarity).
- Bicolor red and yellow LED.
- Indication, by means of the red LED, of the communication with the control panel (single flashing), as well as of the alarm status (LED on).
- Indication, by means of the yellow led (single flash), of the activation of the short-circuit isolator or the lack of communication with the control panel.
- Signaling of the dirty state of the sensor on the control panel display (the sensor allows to differentiate between rapid signal increases due to alarm and small, slow and sustained increases due to the accumulation of dust and dirt).
- Easy installation head and base, interchangeable throughout the A50 family, and made of white heat-resistant ABS.
- UL certificate according to EN 54-7 Standard with CE marking according to the European Regulation on Construction Products (EU) No. 305/2011. Additionally certified EN 54-17 in the A50SI model.

Technical Specifications - A50SI / A50S	
Power supply*	24 – 35 V no polarity*
Standby consumption	0,3 mA
Alarm consumption	2 mA
Activity Indicators	Bicolor LED, red and yellow
Remote indicator output	Yes
Humidity	20 – 95% HR
Temperature	-10° + 50°C
Sensibility	As required by EN 54-5, EN 54-7 (and EN 54-17 A50SHI only)
IP	IP20
Coverage area	104 m ² (subject to local regulation)

***NOTE:** The **Isolated** series (**A50SHCOI, A50SHI, A50HI, A50SI,**) have polarity, as the **A1** and **A2** are positive and **B** is negative.

1.6.1.7- Heat addressable sensors with/without isolator (A50HI / A50H)

The A50 range of detectors is based on a new refined aesthetic that integrates the latest electronic technology with new, more efficient detection algorithms and a three-dimensional design that makes it more robust against environmental dirt.

The A50 range allows multiple combinations between optical and thermal detection, CO sensor and short-circuit UL certification.

The A50HI and A50H models are detectors that have a thermal sensor.

The A50HI model additionally incorporates a short circuit isolator.



Sensor A50HI / A50H

The thermal sensor allows the detector's thermos-velocimetry response, activated at a static temperature of 60°C in the case of slow fire developments.

Specifications:

- Thermal sensor.
- A50SI has a built in short circuit Isolator.
- Low profile, height less than 42 mm (socket included).
- Also available with bigger socket for 20 mm tube.
- Option for attaching a remote action indicator.
- Simplified connection diagram (A50S does not require polarity).
- Bicolor led (Red and Yellow).
- Indication, by means of the red led, of communication with the control panel (single flashing), as well as of the alarm status (led on).
- Indication, by means of the yellow led (single flash), of the activation of the short-circuit isolator or the lack of communication with the control panel.
- Signaling of the dirty status of the sensor on the control panel display (the sensor allows to differentiate between rapid signal increases due to alarm and small, slow and sustained increases due to the accumulation of dust and dirt).
- Easy-to-install head and plinth, interchangeable throughout the A50 range, and made of white heat-resistant ABS.
- UL certified according to Standard EN 54-5 class A2R, EN 54-7 and CE marking according to the European Regulation on Construction Products (EU) No. 305/2011. In addition the A50SI is EN 54-17 certified.

Technical Specifications - A50SHI / A50SH	
Power supply*	24 – 35 V no polarity*
Standby consumption	0,3 mA
Alarm consumption	2 mA
Activity Indicators	Bicolor LED, red and yellow
Remote indicator output	Yes
Humidity	20 – 95% HR
Temperature	-10° + 50°C
Sensibility	As required by EN 54-5, EN 54-7 (and EN 54-17 A50SHI only)
IP	IP20
Coverage area	52 m ² (subject to local regulation)

***NOTE:** The **Isolated** series (**A50SHCOI, A50SHI, A50HI, A50SI,**) have polarity, as the **A1** and **A2** are positive and **B** is negative.

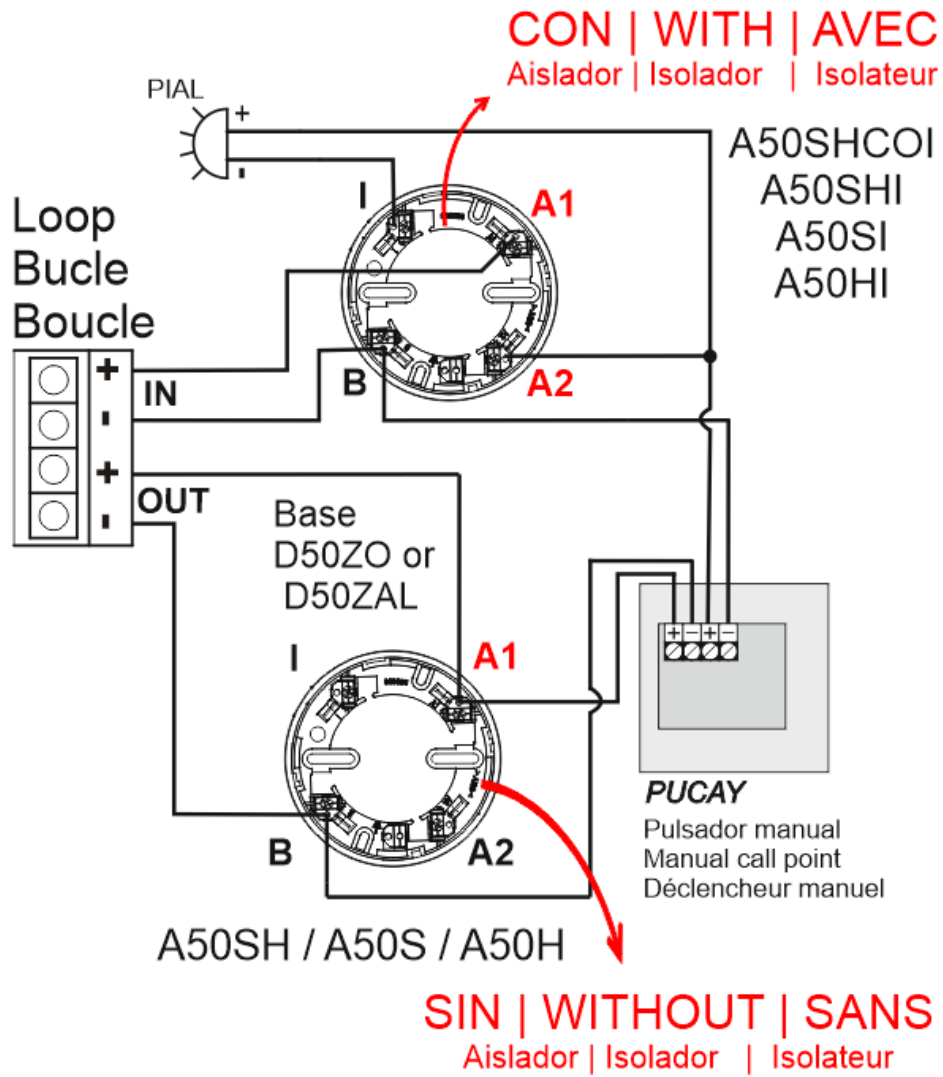

Figure 2B. Schematic diagram for the A50 family and PUCAY

NOTE: If the detector has ISOLATOR the POLARITY must be RESPECTED (B negative, A1 loop input positive B2 loop output positive.)

1.6.2.- Addressable alarm Manual Call Point (PUCA Y)

Microprocessed addressable device (with short-circuit isolator) installed as one more element in the loop.

The re-settable addressable manual call point (with short-circuit isolator) incorporates an action indicator (LED) which is illuminated in the case of being manually activated (alarm).

Push button is easily resettable by actuating the yellow tab on the front face.

The flashing of the transparent red LED indicates communication and if it remains on it indicates the alert status of the button.

There is a version “PUCA YEXT” that it is computed by control panel as the activation of 2 simultaneous devices.



In this way the configured relays can be triggered directly when acting on this version of the switch.

From loop device capacity, PUCA YEXT version is considered identical as a PUCA Y.

The PUCA Y complies with EN 54-11 with the conformity mark awarded by AENOR.

A typical connection diagram is shown in the *figure 2*.

Note: To determine the number of PUCA Y that can be installed in a loop consult the devices limit per control panel table (Chapter 1.5)

Technical specifications PUCA Y	
Supply	24 – 35 V with polarity
Standby consumption	1 mA
Alarm consumption	5 mA
Indicator activation	red LED
Remote indicator output	No
Humidity	20% – 95% RH
Temperature	-10° + 50°C
IP	IP50

1.6.3. - Modules

1.6.3.1- Master detection module (KMAY)

Microprocessed addressable device (with short-circuit isolator) installed as one more element in the loop.

This is a device that allows connecting conventional detectors and/or manual call point inside an addressable fire detection system acting as a bridge between the addressable detection system and the conventional one.

In the “Zone C” terminal, a maximum of 10 conventional call points can be installed. In the “Zone D” terminal allows up to 20 temperature detectors (A30XT, A30XV) or 15 elements between conventional smoke detectors (A30XH, A30XHS) and manual call points. Both terminals are monitored by an end of line capacitor, 10 µF/63V. In this way the status of the line can be known if it is open, shorted to ground or a device entered in alarm state.

The flashing of the transparent red LED indicates communication with the control panel, and if it remains on it indicates the alarm status of a detector or manual call point connected to this module.

This module has an output for activation of a remote indicator which will be activated when alarm status is reached. The Master Detection Module takes the power supply from the loop.

The Master Detection Modules is placed in a rectangular, heat-resistant ABS box.

The KMAY device complies with EN 54-18 with the conformity mark awarded by AENOR.

Note: To determine the number of KMAY it can be installed, consult the devices limit per control panel table (Chapter 1.5)

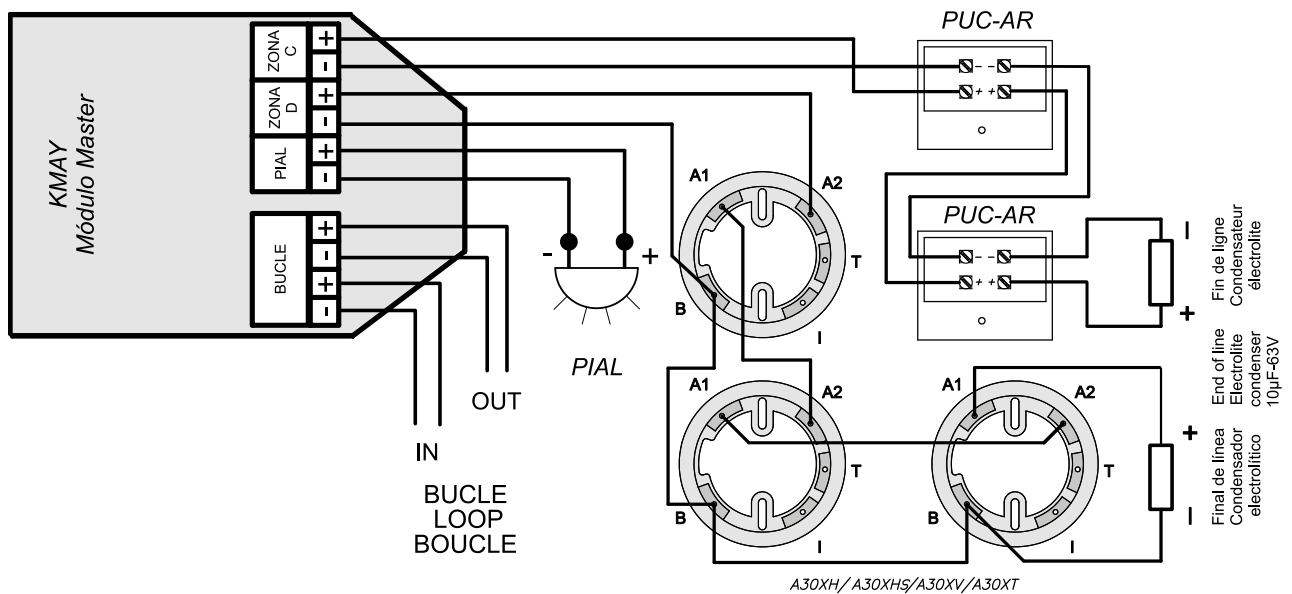

Figure 3. Wiring diagram KMAY

1.6.3.2- Technical signals module (MSTAY)

Microprocessed addressable devices (with short-circuit isolator) installed as one more element in the loop.

It has two inputs to distinguish between the open or close state of a dry contact connected in series with a 10 KΩ resistor. In quiescent condition, the contact has to be open, and in anomaly condition, the contact has to be closed. In the first input (marked with IN1), the closed contact is detected as an ALARM condition. In the second input (marked with IN2), the closed contact is detected as FAULT warning condition. It is possible to associate both inputs having an alarm and fault conditions information.

In the quiescent condition, the device monitors the electrical connection through a 33 KΩ resistor, which allows indication of open or closed electrical connection status.

It is typically used to signal the status of other detection systems that may exist, as for example, connection of flow sensors in the case of sprinkler installations, end of travel in the case of fire-resistant doors, elevators, level of deposits, etc. The flashing of the transparent red LED indicates communication with the Control Panel, and if it remains lit, it indicates an alarm status.



The illumination of the green LED indicates activation of one or both inputs.

This device has an output for connection to a remote action indicator, which is activated when in alarm status. This element is electrical fed through the loop connection.

The MSTAY complies with EN 54-18 with the conformity mark awarded by AENOR.

Note: To determine the number of MSTAY it can be installed, consult the devices limit per control panel table (Chapter 1.5)

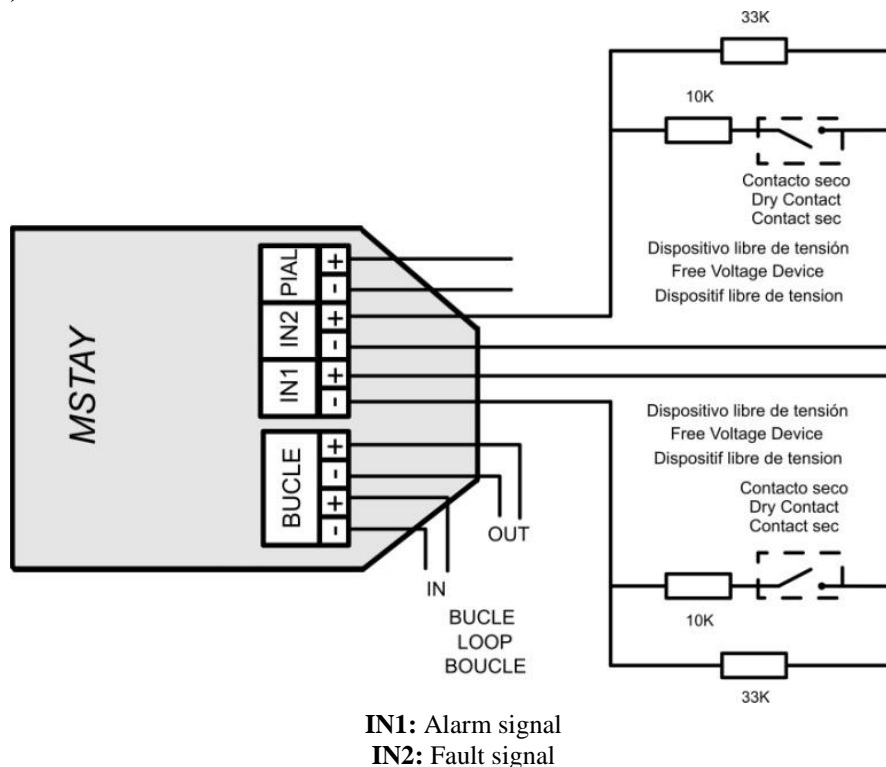

Figure 4. Wiring diagram MSTAY

1.6.3.3- Master relay and technical signals module (MYOA)

Microprocessed addressable devices (with short-circuit isolator) installed as one more element in the loop.

This module has one relay output fed by external 30 V and one technical signal input to distinguish the open or closed state of a dry contact. The Module is protected by 0.9 A resettable fuse and the relay by 0,5 A.

It is required auxiliary 30 V for feeding the equipments connected to the relay output. The relay is configured with only one function (sounder, switched or crossed relay), but also in its timing and in the combination of sensors that activate it. The module monitors the presence of Voltage in the auxiliary supply line of 30V and in the output of the monitored relay. The voltage output of the relay is 30 V.

The technical signal input has a 10 KΩ resistor connected in series with the dry contact. In quiescent condition, the contact has to be open, and in anomaly condition, the contact has to be closed. In the input (marked with **IN2**), the closed contact is detected as **ALARM** condition.

The **MYOA** supervises each external line (relay output and technical signal input) through a 33 KΩ each one, which allows indication of open or closed electrical connection status.

The flashing of the transparent red LED indicates communication with the Control Panel. The illuminated green LED indicates the actuation of the relay an alarm status. Illumination of the green LED indicates activation of the relay or closed dry contact. This module is electrical fed through the loop connection.

The Realy and Technical signal Module is placed in a rectangular, heat-resistant ABS box.

The **MYOA** complies with EN 54-18 with the conformity mark awarded by AENOR.

There is a version with **MYOAF** reference that is identical to MYOA, except the closed contact is detected as a fault.



Note: To determine the number of MYOA devices that can be installed in a loop refer to the devices limit per control panel table (Chapter 1.5)

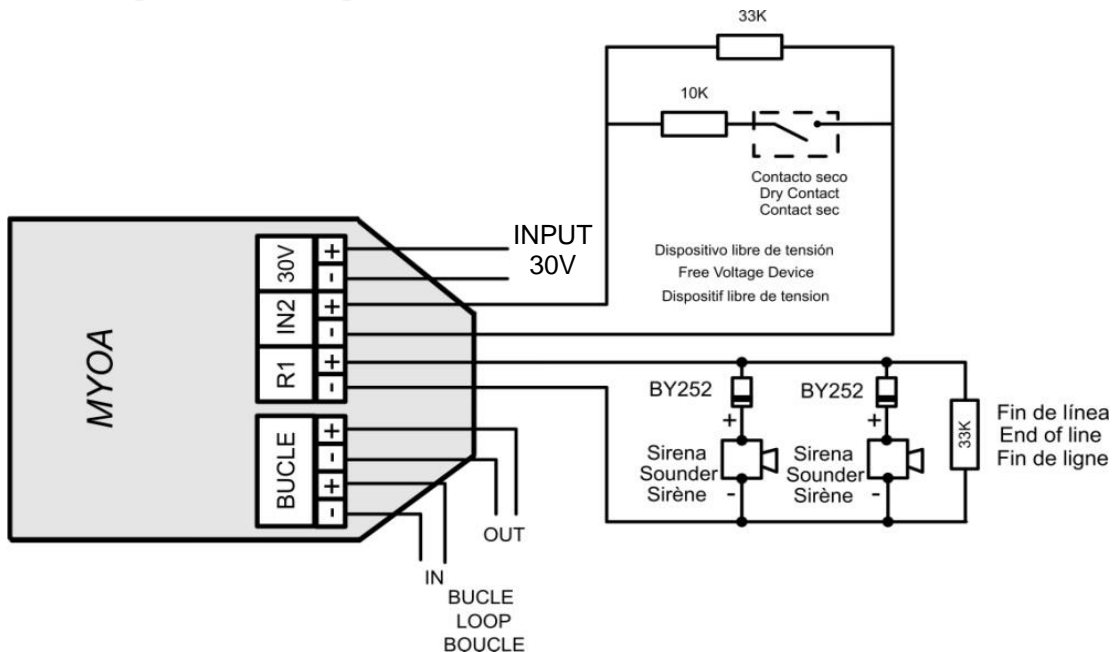

Figure 5. Wiring diagram MYOA

1.6.3.4- Master relays module (MDA1Y)

Microprocessed addressable device (with short-circuit isolator) installed as one more element in the loop.

The module take the power supply from the loop, but they require an auxiliary 30V supply to give the necessary energy to the devices controlled by the relays. They monitor the presence of voltage in the auxiliary supply line of 30V and in the output of the monitored relays. The module is protected by 0.9 A resettable fuse and each monitored output by 0.5 A. The flashing of the transparent red LED indicates communication with the system. Illumination of the green LED indicates the actuation of a relay.

This is a module with two relay outputs of simultaneous activation (with a single function), not only in its type of application (sounder, switches or crossed relay), but also in their timing and in the combination of sensors that activate them.

The R1 output relay is monitored with a line termination resistance of 33K Ω , indicating the state of opened line or crossed line. The R2 output relay acts as a dry contact NO and NC, not monitored, which typical application is the activation of the electromagnets of fire-resistant doors. Considering the consumption produced across the system, it is recommended installation of an External Power Supply when connecting more than 10 electromagnets altogether per detection system.



The MDA1Y device complies with EN 54-18 with the conformity mark awarded by AENOR.

Note: To determine the number of MDA1Y devices that can be installed in a loop consult the devices limit per control panel table (Chapter 1.5)

1.6.3.5- Master relay module (MDA2Y)

Microprocessed addressable devices (with short-circuit isolator) installed as one more element in the loop.

The Modules take the power supply from the loop, but they require an auxiliary 30V supply to give the necessary energy to the devices controled by the relays. They monitor the presence of Voltage in the auxiliary supply line of 30V and in the output of the monitored relays. The Module is protected by 0.9 A resettable fuse and each monitored output by 0,5 A. The flashing of the transparent red LED indicates communication with the system. Illumination of the green LED indicates the actuation of a relay. The device is placed in a rectangular, heat-resistant ABS box.

It is a module with two relay outputs of independent activation (two functions), not only in their type of application (sounder, switches or crossed relay), but also in their timing and in the combination of sensors that activate them. In the standby state, the MDA2Y monitors both external line by means of a 33 K Ω resistance, indicating the state of open line or crossed line.

The MDA2Y device complies with EN 54-18 with the conformity mark awarded by AENOR.



Note: To determine the number of MDA2Y it devices that can be installed in a loop consult the devices limit per control panel table (Chapter 1.5)

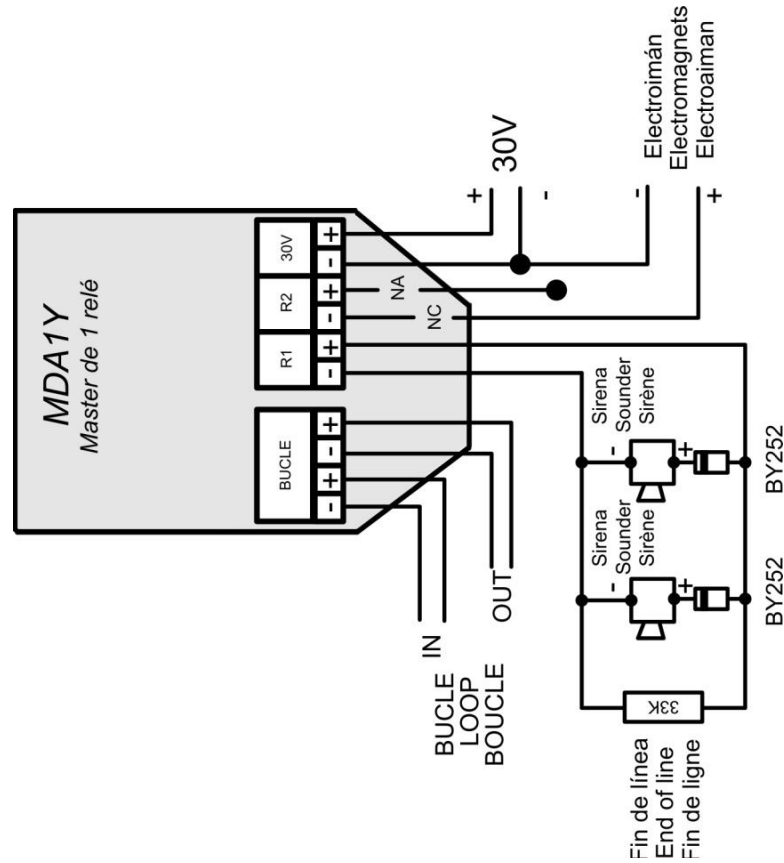

Figure 6. Wiring diagram MDA1Y

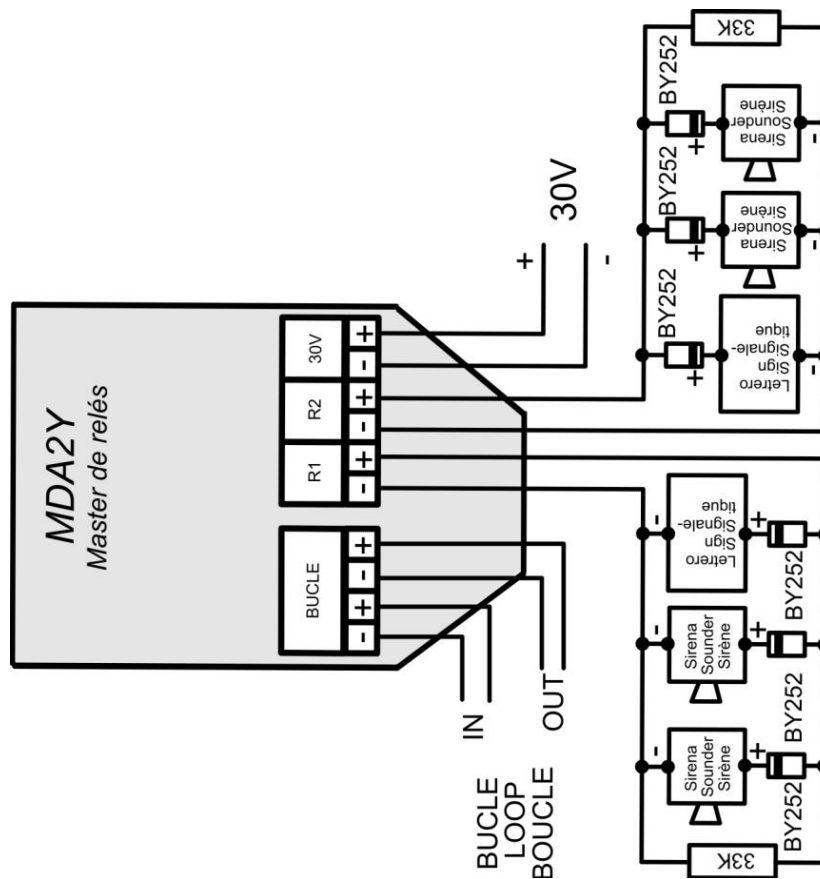

Figure 7. Wiring diagram MDA2Y

1.6.3.6 –Two relay dry contact output module (MDA2YLT)

Microprocessed addressable module (with short-circuit insulator) which is installed as one more element in the loop.

The modules are powered by the loop connection, requiring no outside power.

The blinking red transparent LED shows there is communication with the control panel.

The fixed lit red transparent LED indicates that one or both relays have been triggered.

To order, rectangular boxes made of heat-resistant ABS are available.

This is a module with two relay outputs that are separately activated (two functions), independent timing, as well as a combination of sensors that activate them.

The R1 and R2 outputs are voltage free C/ NC/ NO.

Using this module, we can control fire doors and gates.

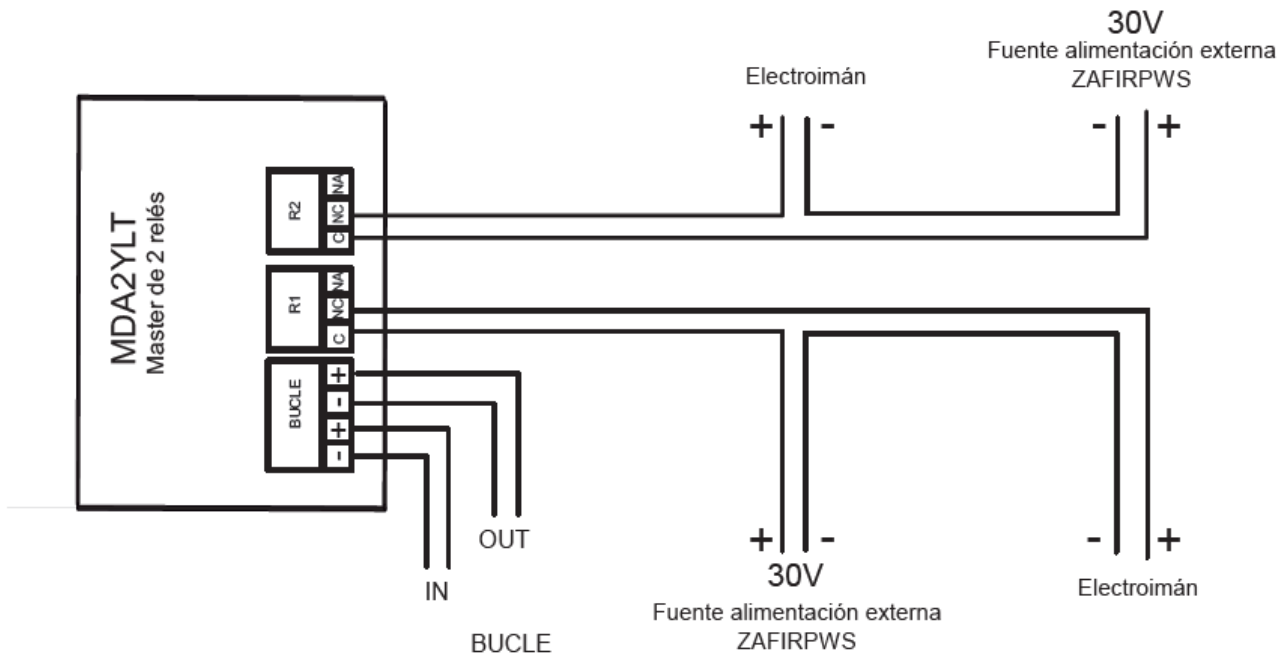
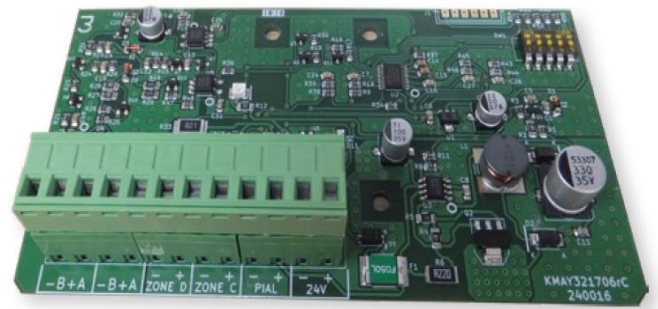

Figure 8. MDA2YLT wiring diagram

1.6.3.7-Module to connect 32 detectors / 10 manual call points (KMAY32)

Microprocessed addressable module (with short-circuit insulator) which is installed as one more element in the loop.

This module allows the connection of conventional detectors and/or alarm call points in an algorithmic-addressable fire detection system, acting as a bridge between an algorithmic-addressable control panel and a conventional system.



Up to a maximum of 10 conventional alarm call points can be installed on the strip of “Zone C”. The “Zone D” strip allows a maximum of 32 temperature detectors (A30XT, A30XV) or 32 components between smoke detectors (A30XH, A30XHS) and conventional alarm call points. Both strips supervise the line using a 4K7end-of-line resistor. It thus indicates the status of the open line, crossed line, detector alarm or alarm call point alarm.

It has a microswitch for setting the area thresholds;

- Open line threshold (pin microswitch 1-2).
- Detector alarm triggered threshold (pin microswitch 3-4).
- Alarm call point triggered threshold (pin microswitch 5).

The blinking of the red transparent LED indicates communication with the control panel, and if it stays on in indicates the status of the alarm of a detector or of an alarm call point connected to that module.

This module has an output for the activation of a remote pilot, which is activated when it is in alarm state.

This module is powered by the loop connection and requires a 24V auxiliary power supply to power the areas, said voltage is supervised by the microcontroller. Rectangular boxes made of heat-resistant ABS are available on order.

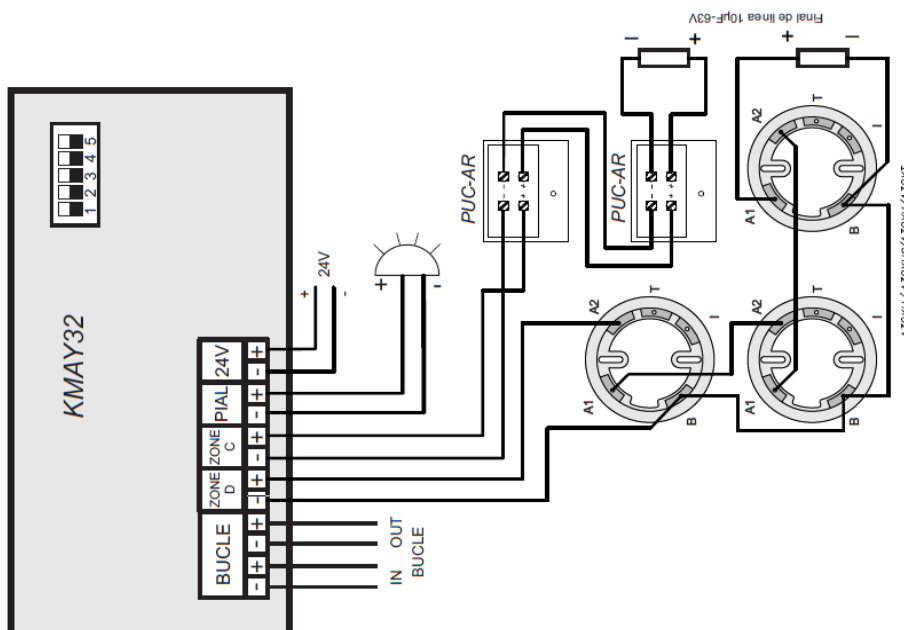

Figure 9. KMAY32 wiring diagram

1.6.3.8 –Module with 8 inputs (MSTAY8)

Microprocessed addressable module (with short-circuit insulator) which is installed as one more element in the loop.

It has eight inputs for external equipment monitoring. Each input is configured as an independent MSTAY module which is identified by independent programming number.

It is typically applicable for signaling the status of other detection systems in which there could be a connection to flow sensors in the case of sprinkler installations, travel path end-stops in the case of fire doors, lifts, tank levels, pressure units, etc.

These inputs are configurable by microswitch in the following manner:

- Supervised (pin 1 microswitch set to ON); the outside line in supervised standby state by means of a 33K Ω resistor, indicating the status of the line or crossed line. Connecting a parallel 10k Ω resistor will activate the related input.
- Active by closed contact (pin 1 microswitch set to OFF and pin 3 microswitch set to OFF); the input in standby must be with the contacts open, in case of event the input contacts must be crossed. This will be the factory settings.
- Active by open contact (pin 1 microswitch set to OFF and pin 3 microswitch set to ON); the input in standby must be with the contacts crossed, in case of event the contacts must be opened.

Using pin 2 of the configuration microswitch we will select the type of event that the module will send to the control panel: ON Fault and OFF Alarm.

The configuration of the inputs is common to all of them.

The blinking of the transparent red LED indicates communication with the control panel and also if it stays lit it indicates the activation of one or several inputs.

This module has an output for the activation of a remote pilot, which is activated when it is in alarm state.

The Technical Signals module is powered by the connection to the loop.

Rectangular boxes made of heat-resistant ABS are available on order.

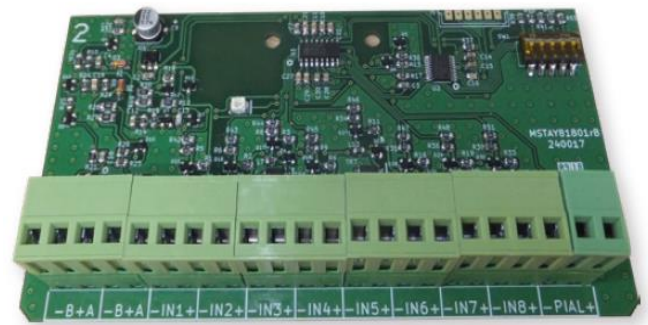

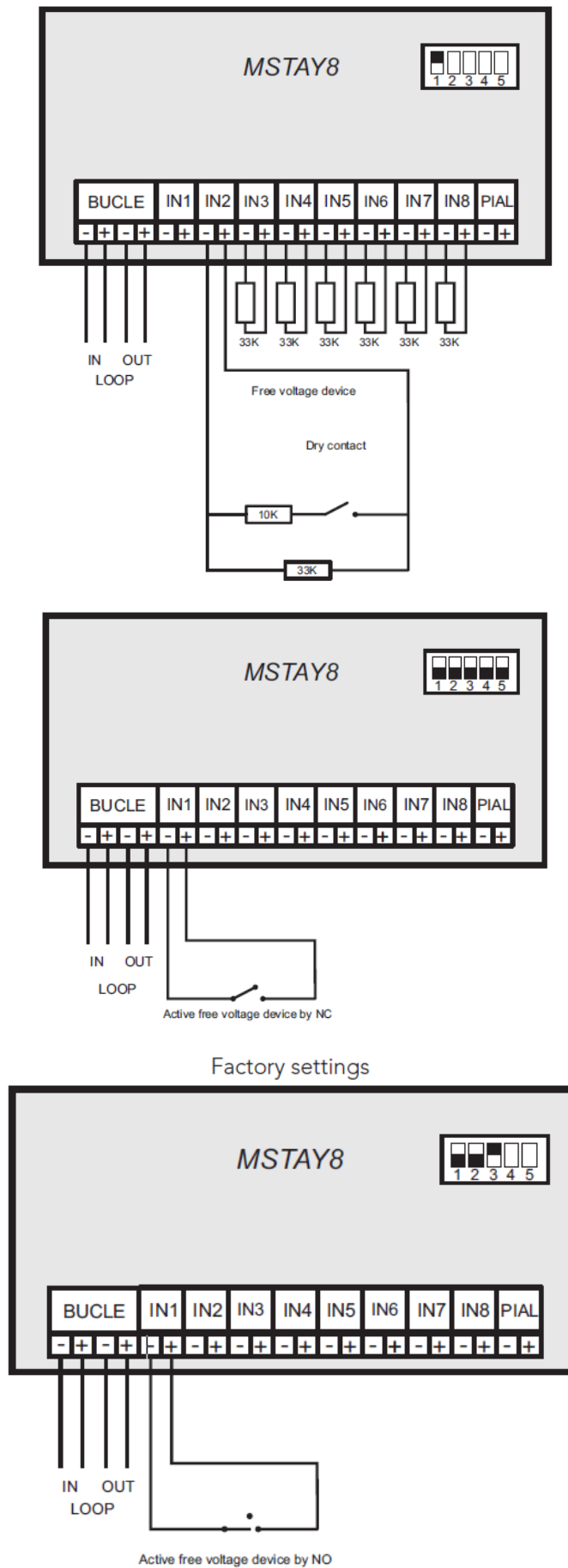

Figure 10. MSATY8 wiring diagram configurations

1.6.3.9- Loop isolator (KABY)

The kaby element installed as another element inside the loop (It is not addressable - There is not need to configure this element).

This is a protection element that is connected into the detection loop, with the aim of isolating stretches with crossed line failures, and allowing therefore the rest of the loop to operate normally.

It is supplied installed inside of a high base. This assembly allows having it in the same place as the sensor, making easy the connection of the loop wiring.

The base has two stickers in the outer side with the word “KABY” to allow easy recognition.

The element is feed from the loop connection.

The **KABY** is conformant with EN 54-17 with the conformity mark awarded by AENOR.

Note: To determine the number of **KABY** devices that can be installed in a loop consult the devices limit per control panel table (Chapter 1.6)

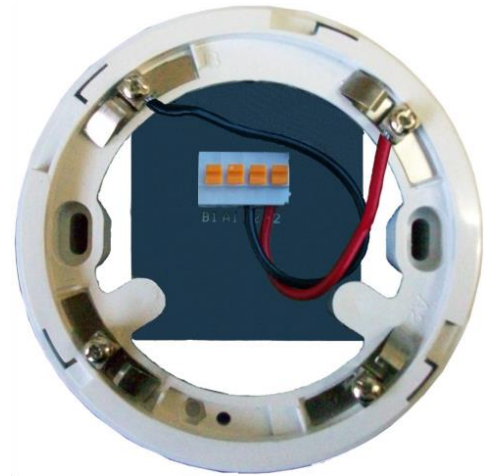

IMPORTANT The polarity in the **KABY** is showed in *figure 11*

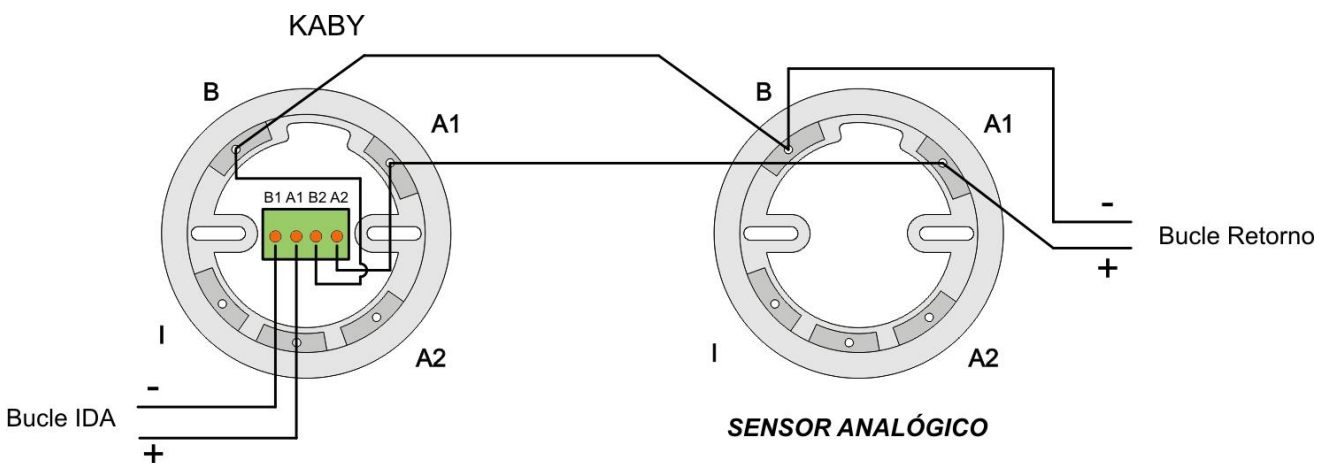

Figure 11. KABY wiring diagram

1.6.3.10- Addressable sounder (SIRAY / SIRAYL / SIRAY+BSLC)

Microprocessed addressable sounder (with short-circuit isolator) installed as another element inside the loop.

This sounder is manufactured in red plastic ABS.

It is a module with a single programming function respecting the timing and combination of elements that activate it. This sounder is configured as a relay being able to act as a sounder.

The SIRAYL and SIRAY+BSLC variants additionally emits light signals, where, SIRAY+BSLC is EN 54-23 certified (visual alarm devices). The fact that these sirens emit light specifically does not affect the programming of control panel. For this reason, these devices are programmed in the control panel as it was SIRAY.

The standard configuration of the sound of the siren is shown in **Figure 12A** according to EN 54-3 (sounder). In the same figure the standard configuration of the light signal in the socket of the SIRAY+BSLC siren according to EN 54-23 (visual alarm device) is shown.

It is allowed to change the selection of the tone and light signal, but this operation affects the power consumption of the sounder, and therefore consumption elements equivalence of the device. Equivalence to tone selections (standard 95-1m dB and 105 dB maximum sound intensity-1m) and visual signal (W-2,4-2,3/7,5). Calculation can be made with the software of loop elements capacity calculation.

It is shown the microswitchs position for standard and maximum loudness at **figure 12A**, also including light signal for standard or maximum power emission.

Internal wiring and other microswitch positions should not be modified.



SIRAY



SIRAYL



SIRAY+BSLC

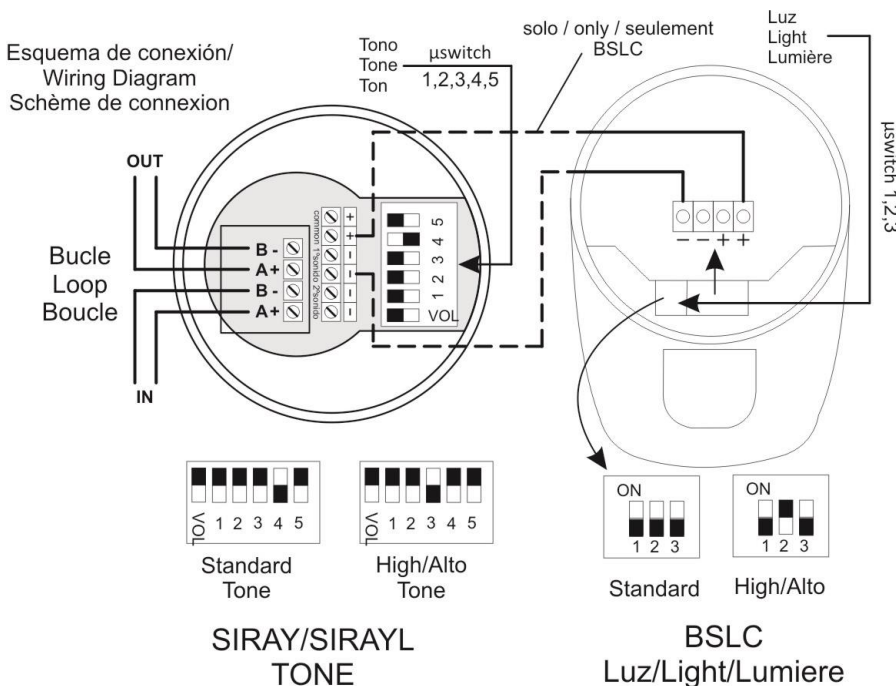

Figure 12A. SIRAY / SIRAYL / SIRAY+BSLC Schematic connection

1.6.3.11- Remote indicator (PIAL)

Remote action indicator of fire detection systems.

Typical cases of use:

- Places where elements of the detection system are not visible, for example, inside false ceiling, in which the PIAL can be visibly situated on the lower part of the ceiling or near the wall.
- Reduced accessibility rooms or that is needed do a big inspection range for the identification of the element in alarm, for example in hotel rooms, where the PIAL can be situated above the door frame of each room, making very easy its identification.



Permanent activation of the red LED indicates alarm status.

It is an element easy to install, both for its electrical wiring and its fixation. Furthermore it can be adapted to the conduit boxes and switchgear.

Features:

- Alarm status can be identified in any perpendicular direction at its installation.
- Easy connection, with polarity.
- Can be adapted to the conduit boxes and switchgear.
- The red light is produced by two LEDs, increasing reliability against failure of any of them.
- Manufactured in heat-resistant ABS. Base and lid are white, red viewer.



SOLO para sistema analógico
ONLY for analogue system
JUSTE pour système analogique

SOLO para sistema convencional
ONLY for conventional system
JUSTE pour système conventionnel

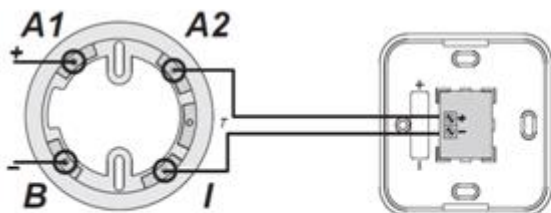

Esquema analógico / Analogue wiring diagram

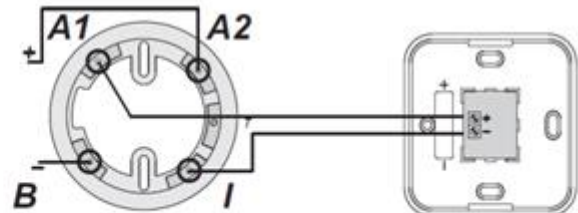

Esquema convencional / Conventional wiring diagram

Figure 13. General wiring diagram for PIAL

1.6.3.12-Base with siren and visual alarm (A50ZSLDR / A50ZSDDR)

Base for addressable sensors A30X with certified base for visual alarm and sound EN 54-23 and sound EN 54-3 powered directly from the loop.

This device needs an addressable sensor "with SIRDR functionality" (standard sensors do not have this functionality) which will allow it to operate as a relay associated to this sensor.

This device is configured in the addressable system as a relay associated with its sensor (SIRDR)

The typical uses of the A50ZSDDR and A50ZSLDR are spaces that need integrated fire detection equipment with siren and visual alarm, such as hotel rooms equipped for clients with hearing impairments, waiting rooms, nursing rooms, etc.

The coverage of the set should not be greater than the coverage of the fire sensor with which it is installed, except for reasons that justify it.

Functionally, the sensor is wired according to the criteria of the fire panel to which it is connected.

Two models are available:

- **A50ZSLDR:** Base Socket with light and sound, addressable
- **A50ZSDDR:** Base Socket with sound, addressable

A diode is embedded in socket.



A50ZSDDR + A50SHI



A50ZSLDR + A50SHI

Technical Specifications	A50XZSDDR	A50XZSLDR
Voltage input	18-30 V with polarity	18-30 V with polarity
Quiescent current	0 mA	0 mA
Alarm current state	HIGH 6 mA LOW 5 mA	HIGH 21 mA LOW 19 mA
Operating temperature	-10°C+50°C	-10°C+50°C
Ingress Protection	IP21C	IP21C
Sound intensity	HIGH 96 dB-1m LOW 90 dB-1m	HIGH 96 dB-1m LOW 90 dB-1m
Tones	31 types	31 types
Certification	EN 54-3	EN 54-3 ; EN 54-23
Flash	-	0.5 Hz (60ms)

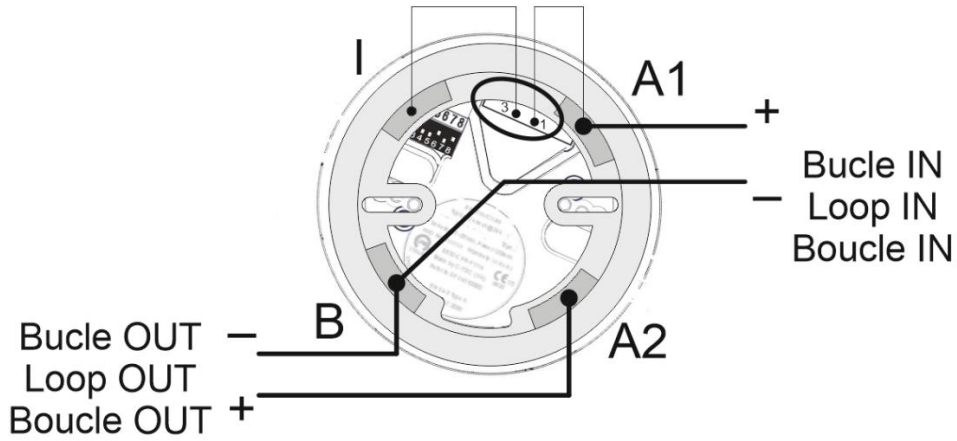
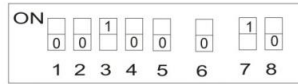

Figure 14A. Wiring diagram A50XZSDDR/A50XZSLDR

Selección recomendable / Recommended selection
Sélection recommandée

DIP 00100 0 10



31 Tono /Tones
Nivel sonido
Sound level
Niveau sonore

Sin función
Without function
Sans fonction

1- Alto / High / Haute
0- Bajo / Low // Bas

Figure 14B. Configuration DIP A50XZSDDR

Selección recomendable / Recommended selection
Sélection recommandée

DIP 00100 0 10

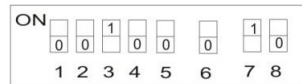

31 Tono /Tones

Nivel sonido
Sound level
Niveau sonore

1- Alto / High / Haute
0- Bajo / Low // Bas

Luz/Light/Lumiere

0 0 - Off
1 0 - C-3-8.5 / 0.5 Hz
0 1 - C-3-8.5 / 1 Hz
1 1 - Power safe / 0.5 Hz

Figure 14C. Configuration DIP A50XZSLDR

1.6.3.13-Base with siren and visual alarm (A30XZSLDR / A30XZSDDR)

Base for addressable sensors A30X with certified base for visual alarm and sound EN 54-23 and sound EN 54-3 powered directly from the loop.

This device is configured in the addressable system as a relay associated with its sensor (SIRDR)

The typical uses of the A30XZSDDR and A30XZSLDR are spaces that need integrated fire detection equipment with siren and visual alarm, such as hotel rooms equipped for clients with hearing impairments, waiting rooms, nursing rooms, etc.

The coverage of the set should not be greater than the coverage of the fire sensor with which it is installed, except for reasons that justify it.

Functionally, the sensor is wired according to the criteria of the fire panel to which it is connected.



A30XZSDDR +A30XHA

Two models are available:

- **A30XZSLDR** : Base Socket with light and sound, addressable
- **A30XZSDDR**: Base Socket with sound, addressable

A diode is embedded in socket.

Notes:

- The section and type of cable will be according to what is indicated in the power supply equipment
- Do not manipulate the inside of the appliance
- Do not delete indications that each device has written
- Disconnect the mains voltage and the batteries from the system before handling the appliance.



A30XZSLDR +A30XHA

Technical Specifications	A30XZSDDR	A30XZSLDR
Voltage input	18-30 VDC	18-30 VDC
Quiescent current	0 mA	0 mA
Alarm current state	HIGH 6 mA LOW 5 mA	HIGH 21 mA dB LOW 19 mA
Operating temperature	-10°C+50°C	-10°C+50°C
Ingress Protection	IP21C	IP21C
Sound intensity	HIGH 96 dB-1m LOW 90 dB-1m	HIGH 96 dB-1m LOW 90 dB-1m
Tones	31 types	31 types
Certification	EN 54-3	EN 54-3 ; EN 54-23
Flash	-	0.5 Hz (60ms)

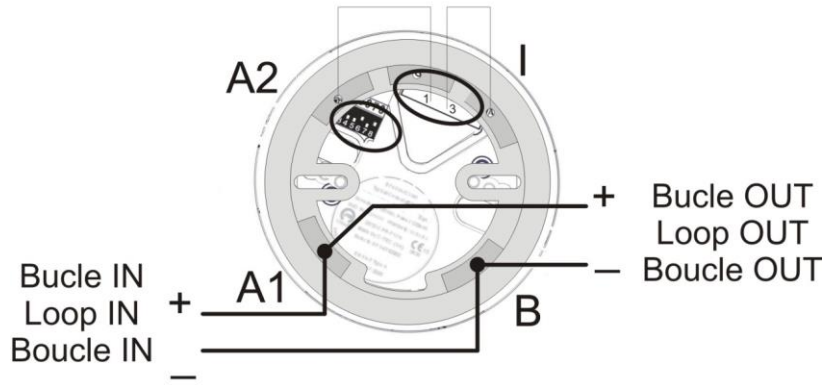
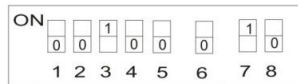

Figure 14A. Wiring diagram A30XZSDDR/A30XZSLDR

Selección recomendable / Recommended selection
Sélection recommandée

DIP 00100 0 10



DIP 1-5 6 7-8

31 Tono /Tones

Nivel sonido
Sound level
Niveau sonore

Sin función
Without function
Sans fonction

1- Alto / High / Haute
6 0- Bajo / Low // Bas

Figure 14B. Configuration DIP A30XZSDDR

Selección recomendable / Recommended selection
Sélection recommandée

DIP 00100 0 10

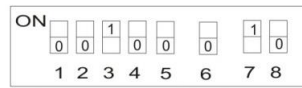

31 Tono /Tones

DIP 1-5 6 7-8

Nivel sonido
Sound level
Niveau sonore

1- Alto / High / Haute
0- Bajo / Low // Bas

Luz/Light/Lumiere

0 0 - Off
1 0 - C-3-8.5 / 0.5 Hz
0 1 - C-3-8.5 / 1 Hz
1 1 - Power safe / 0.5 Hz

Figure 14C. Configuration DIP A30XZSLDR

1.6.3.14- A50 family detectors with Light and sound integrated (A50xxLD/A50xxD/A50xxL)

A50 family fire sensor with additional functionality of visual alarm device (Light) and fire sounder (sound) integrated in a single device.

Within the A50 range, multiple combinations of optical, heat, optical-heat and UL-certified short-circuit isolator detection are possible.

To these functionalities can be added the visual alarm device functionality (A50xxL) based on EN 54-23, the fire sounder functionality (A50xxD) based on EN 54-3, or both (A50xxLD).

The different models are:

A50SHILD: A50SHI with light and sound

A50SILD : A50SI with light and sound

A50HILD : A50HI with light and sound

A50SHID: A50SHI with sound

A50SID : A50SI with sound

A50HID : A50HI with sound

A50SHIL: A50SHI with light

A50SIL : A50SI with light

A50HIL : A50HI with light



Detector A50xxLD /A50xxL



Detector A50xxD

Specifications:

- Different models with optical, heat or optical-heat sensor. All sensors independents.
- Built-in short-circuit isolator.
- Low-profile base (not included).
- Capacity of up to 64 devices per loop in Lyon control panel.
- The control panel allows setting the optical and acoustic alarm output with two different intensity levels for rooms of 21 or 30 m2.
- Possibility of connection to a remote action indicator.
- Easy to connect.
- Red and yellow bicolor LED.
- Indication, by the red LED, of the communication with the control panel (single flashing), as well as of the alarm status (LED on).
- Indication, by the yellow LED (single flashing), of the activation of the short-circuit isolator or the failure to communicate with the control panel.
- Indication of the sensor's dirt status on the control panel display (the sensor can differentiate between rapid signal increases due to alarms and small, slow, sustained increases due to accumulation of dust and dirt).
- Easy-to-install head and base, interchangeable on the entire A50 range, made of heat-resistant white ABS.
- UL certified according to EN 54-5 class A2R, EN 54-7, EN 54-17, EN 54-3 and EN 54-23 with CE marking according to the European Construction Products Regulation (EU) No 2024/3110.

Technical Specifications - A50xxLD	
Power supply*	24 – 35 V no polarity*
Standby consumption	0,3 mA
Alarm consumption	15 mA/ 0,36 mW
Activity Indicators	Bicolor LED, red and yellow
Remote indicator output	Yes
Humidity	20 – 95% HR
Temperature	-10° + 50°C
Sensibility	As required by EN 54-5, EN 54-7 and EN 54-17 depending on detector sensors
IP	IP21C
Detection Coverage area	104 m ² / 52 m ² dependeing on detection sensors (subject to local regulation)
Visual Alarm Device	C-3-7,65 0,5 Hz
Sounder Alarm Device	87 dB-1m Sweep 1s 2650-3000 Hz

Technical Specifications - A50xxL	
Power supply*	24 – 35 V no polarity*
Standby consumption	0,3 mA
Alarm consumption	15 mA/ 0,36 mW
Activity Indicators	Bicolor LED, red and yellow
Remote indicator output	Yes
Humidity	20 – 95% HR
Temperature	-10° + 50°C
Sensibility	As required by EN 54-5, EN 54-7 and EN 54-17 depending on detector sensors
IP	IP21C
Detection Coverage area	104 m ² / 52 m ² dependeing on detection sensors (subject to local regulation)
Visual Alarm Device	C-3-7,65 0,5 Hz

Technical Specifications - A50xxD	
Power supply*	24 – 35 V no polarity*
Standby consumption	0,3 mA
Alarm consumption	10 mA/ 0,36 mW
Activity Indicators	Bicolor LED, red and yellow
Remote indicator output	Yes
Humidity	20 – 95% HR
Temperature	-10° + 50°C
Sensibility	As required by EN 54-5, EN 54-7 and EN 54-17 depending on detector sensors
IP	IP21C
Detection Coverage area	104 m ² / 52 m ² dependeing on detection sensors (subject to local regulation)

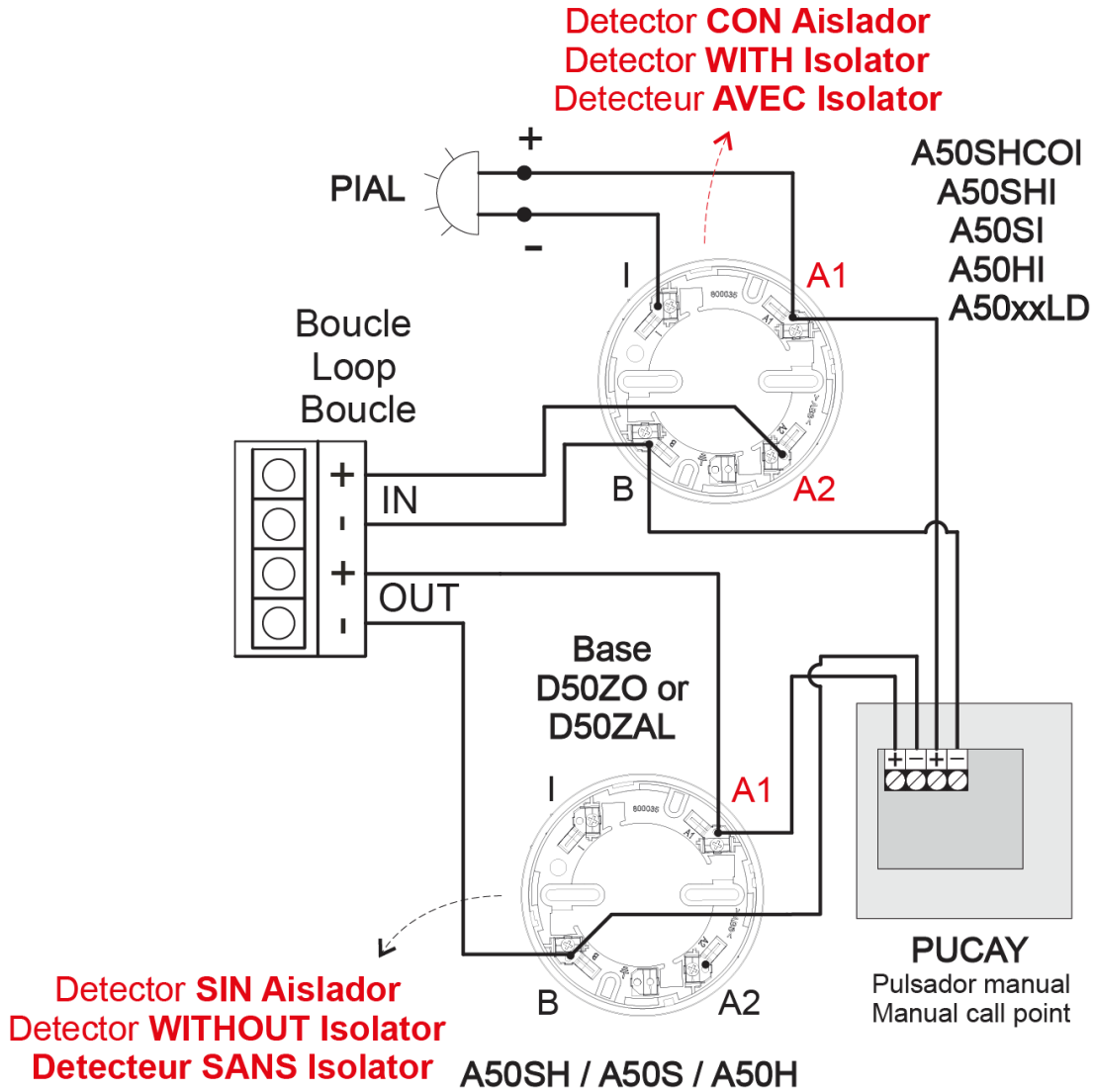

Figure 2B. Schematic diagram for the A50 family and PUCAY

NOTE: If the detector has ISOLATOR the POLARITY must be RESPECTED (B negative, A1 loop input positive B2 loop output positive.)

1.6.4- Repeaters

1.6.4.1- Installation

The repeater must be fixed on a vertical wall face. The side slots must be left free for heat to escape. The dimensions and the pre-drilled holes for cable entry are shown in the following diagram.

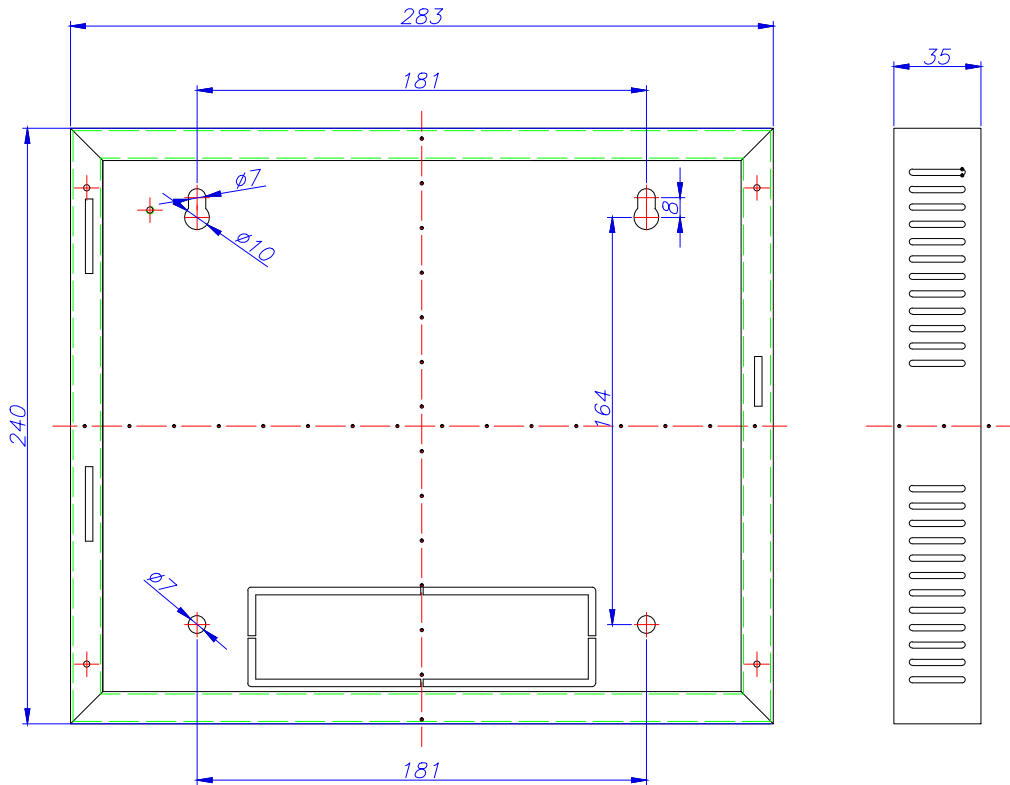

Figure 15. ZYR repeater box

The ONIX/QUARTZ control panel allows connecting up to 15 repeaters. For this, a 4-wire connection of 1.5 mm² wires (two for power supply and two for RS485 communication) must be used.

The two wires for the RS485 line must be connected from the connector indicated as REPETIDOR at the Control Panel, with each connector of the repeaters indicated as REPETIDOR on the label.

The two power supply wires must be connected from the 30 V output of the Control Panel power supply, with the connector labeled with 30 VDC in each repeater. The repeaters must be connected as shown in figure 16.

It can be used the ONIX/QUARTZ control panel's power supply 30V output for 1 repeater. In other cases (from 2 to 15 repeaters), it must be used the 30 V output of an auxiliary power supply (FAE).

For repeaters connection, both the communication and 30V power supply cables must be **2 x 1.5 mm HALOGEN-FREE SCREENED BRAIDED CABLE**, with a maximum cable length of 1200 metres.

On completing the installation, a 120 Ohm resistor must be connected between the terminals A and B in the "REPETITOR" connector of the last repeater connected.

DISCONNECT the 110-230Vac voltage circuit before accessing the interior of the control panel , and then disconnect the batteries.

1.6.4.2. Operation and Configuration

The repeaters display all the information about alarms, disconnections, relay actuations and faults. Once the repeaters have been connected, they must then be configured in the control panel by entering the number of each repeater to be configured.

To do this, follow this sequence in the control panel: Menu (access code 27) → 4. System setup (access code 9000) → 8 Communications → 1- Repeater network → 2 - Configure repeaters.

Main	
1. Monitoring	
2. Logic relay activation	
3. General relays	
4. System Setup	
4.1.	Label points
4.2.	Configure
4.3.	Set up time and date
4.4.	Day/night timetable
4.5.	Swap test/normal
4.6.	Led ON/OFF
4.7.	Language menu
4.8.	Communications
4.8.1.	Repeater network
4.8.1.1	View configured repeaters
4.8.1.2	Configure Repeaters
4.8.1.3	Autodetect slaves
4.8.1.4	Erase repeater
4.8.1.5	Delete repeaters
4.8.1.6	Label Repeater

Control Panel Menu

After configuring the control panel, a number must then be assigned to each repeater. This must be the same as the one which was configured in the control panel. To do this, follow this sequence in the corresponding repeater:

Menu (access code 27) → 1. System setup (access code 9000) → 3.Address number.

1.	System setup	Menu_1
1.1.	Additional passwords	Menu_2
1.2.	Language menu	Menu_3
1.3.	Repeator address	Option_1
2.	General Rearm	Option_2
3.	System Test	Option_3
4.	Welcome message	Option_4

Repeater Menu

When configuration has been completed, the general system reset must be performed from the control panel. To do this, follow this sequence: Menu (access code 27) → 8- General reset.

Main	
1. Monitoring	
2. Logic relay activation	
3. General relays	
4. System Setup	
5. Enable/disable points/zones	
6. System Test	
7. Welcome message	
8. General Rearm	
9. Review history	

Control Panel Menu

The zone names must then be sent according to this sequence in the control panel:

Menu (access code 27) → 4. System Setup (access code 9000) → 2 Configure → 9 Send Zones to Repeaters.

Main

1. Monitoring

2. Logic relay activation

3. General relays

4. System Setup

4.1. Label points

4.2. Configure

4.2.1. Loop configuration

4.2.2. Logic In/out configuration

4.2.3. Configure alarm zones

4.2.4. Set up point sensitivity

4.2.5. Additional Passwords

4.2.6. Autoevacuation Setup

4.2.7. Added Delay Setup

4.2.8. Fast trigger Zone

4.2.9. To Send Zones to Repeaters

Control Panel Menu

Functions that can be carried out from the repeater:

- Reset alarms and faults.
- Activate or deactivate silence sounders.
- Activate or deactivate evacuation.
- Activate or deactivate manual mode.
- Activate or deactivate delays.
- Deactivate the buzzer.
- General reset.



1.6.4.3.- Repeater menus

The following menus are accessible in the repeater:

1.System setup	Menu_1
1.1.Additional passwords	Menu_2
1.1.1. 2nd level password	"27"
1.1.2. 3rd level password	"9000"
1.2.Language menu	Menu_3
1.2.1. Set Language to Spanish	
1.2.2. Set Language to English	
1.2.3. Set Language to French	
1.2.4. Set Language to Italian	
1.2.5. Set Language to Hungarian	
1.2.6. Set Language to Ukrainian	
1.2.7. Set Language to Portuguese	
1.2.8. Set Language to Turkish	
1.2.9. Set Language to Romanian	
1.2.10. Set Language to Bulgarian	
1.3.Repeater address	Option_1
2.General Rearm	Option_2
3.System Test	Option_3
4.Welcome message	Option_4

Repeater_menu

- 1. SYSTEM SETUP
 - 1.1. ADDITIONAL PASSWORDS: From this menu, an additional password can be entered for access level 2 and another password for access level 3. Every time a new password is entered, the password entered previously will be deleted. The passwords which came pre-installed from the factory (access level 2: **27**; and in access level 3: **9000**) cannot be deleted.
 - 1.2. LANGUAGE MENU: From this menu, the repeater's language can be selected. The repeater has Spanish, English, French, Italian, Hungarian, Ukrainian and Portuguese pre-installed at factory.
 - 1.3 REPEATER NUMBER: From this menu, the repeater number to be used when communicating with the control panel can be selected. This number can never be used in more than one repeater.
- 2. GENERAL REARM: From this option, the whole system can be reset. When the system is reset, all the events are deleted from the control panel and the repeaters, i.e. alarms, faults and relay actuations. The status of the elements and/or zones that are out of service is maintained.
- 3. SYSTEM TEST: This option is used to test the repeater's indicators. In this test, all the leds should light up, the buzzer should sound, and the following screen should be displayed:

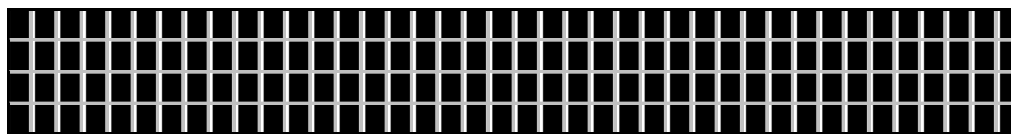

- 4. WELCOME MESSAGE: From this option, the welcome message can be changed. The welcome message is the text that is displayed in the first line when the repeater is in standby. This message can have up to 40 characters. These are entered using the repeater's cursors or an external keyboard.

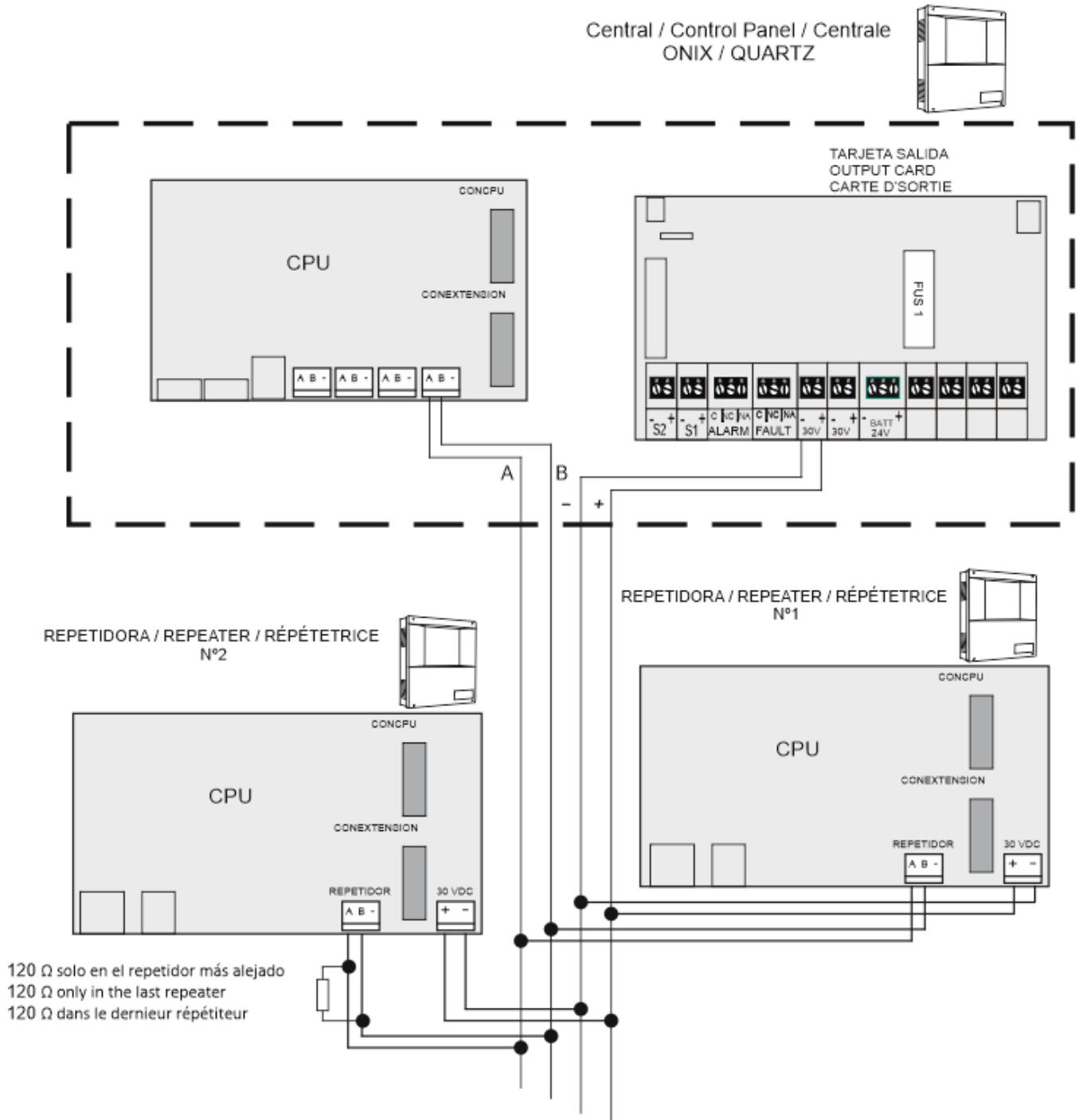

Figure 16. Repeater connection diagram. Max 15

1.6.5- Control panel network

1.6.5.1- Installation

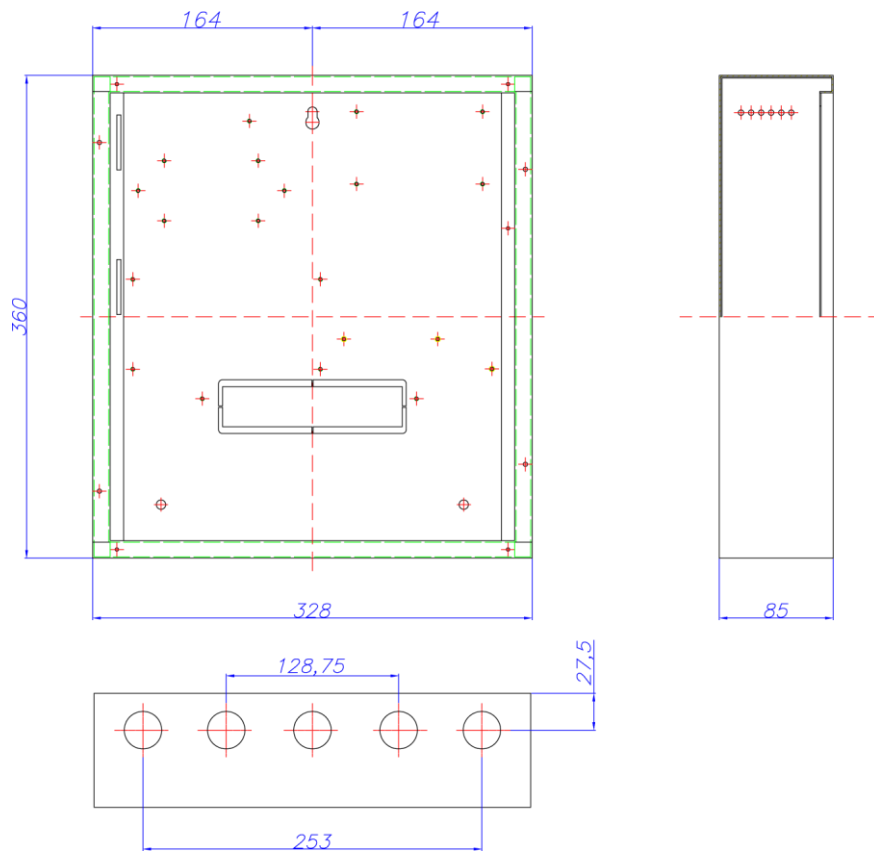

Figure 17. Onix/Quartz box

The control panel must be fixed on a vertical wall face. The side slots must be left free for heat to escape. The dimensions and the pre-drilled holes for cable entry are shown in the following diagram.

Cofem Digital Detection System allows to connect up to 15 control panels in a network, by connecting 2 wires of 1,5 mm² (RS485 communication line).

The two wires of the RS485 line will be connected from the CP NETWORK indication in the CPU card of each control panel. This connection is shown in *figure 18*.

Power is held in each control panel separately. Each control panel will be connected to the 110-230V mains and its corresponding set of batteries.

The communication cables connection between control panels will be made with **cable 2 x 1,5 mm twisted shielded halogen free, up to a maximum cable length of 1200 meters.**

On completing the installation, a 120 Ohm resistor must be connected between the terminals A and B in the **CP NETWORK** connector both the first and the last control panel connected.

DISCONNECT the 110-230Vac voltage circuit before accessing the interior of the control panel , and then disconnect the batteries before handling the inside of the control panel or the repeaters.

1.6.5.2- Operation and configuration

Each control panel in the network displays all information from other control panel and interact with each other.

Once the Control Panel is up, proceed to assign a **different number** to each **Control Panel**.

For this we perform the following:

Menu (code 27) → **4**- System Setup (code 9000) → **8**- Communications → **4**- Set control panel number.*

Main

1. Monitoring

2. Logic relay activation

3. General relays

4. System Setup

4.1. Label points

4.2. Configure

4.3. Set up time and date

4.4. Day/night timetable

4.5. Swap test/normal

4.6. Led ON/OFF

4.7. Language menu

4.8. Communications

4.8.1. Repeater network

4.8.2. Control Panel Network

4.8.3. Contact ID

4.8.4. F.A.C/ModBus Protocol

4.8.5. Set Control Panel Number

4.8.6. View Control Panel Number

4.8.7. Communication mode → (Com1/Com2/Com3/Com4/USB)

4.8.8. Consult Version

4.8.9. Remote connection

Control Panel Menu

To check the central number, please enter in “4.8.6 View Control Panel Numer”.

After the configuration should perform a general reset at each control panel of the network. For this we perform the following sequence: Menu (code 27) → **8**- General rearm.

Main

1. Monitoring

2. Logic relay activation

3. General relays

4. System Setup

5. Enable/disable points/zones

6. System Test

7. Welcome message

8. General Rearm

9. Review history

A control panel in the network can perform the same functions as any normal control panel. You can also perform the following functions on the rest of the control panels of the network:

- Reset alarms and faults in the network control panels.
- Reset all the network control panels.
- Enable or disable without delay mode in all network control panels.
- Enable or disable sirens stop in all network control panels.
- Enable or disable the evacuation in all network control panels.
- Enable or disable manual mode in all network control panels.
- Disable the buzzer in all network control panels.

1.6.5.3- Control panels network menu

In the control panels we can find the next specific control panels network menus:

- **VIEW CONTROL PANELS:** Visualize the set control panels.
- **RESET CONTROL PANEL NETWORK:** Reset all the control panels in the network.
- **NETWORK KEYS CONFIG:** Allow to activate/deactivate the keys (no delay, silence sounder, evacuate, manual mode, buzzer) automatically, only when these are activated/deactivated by another Control Panel connected in the panel network.

4.8.2. Control Panel Network	
4.8.2.1	See Control Panels
4.8.2.2	Reset control panel network
4.8.2.3	Network Keys Config
4.8.2.3.1	Activate
4.8.2.3.2	Deactivate

- **SET CONTROL PANEL NUMBER:** Every central must have a **unique number** in network. Number accepted are between (1-35), but max number of repeater is 15, and 15 control panels
- **VIEW CONTROL PANEL NUMBER:** View the current central number

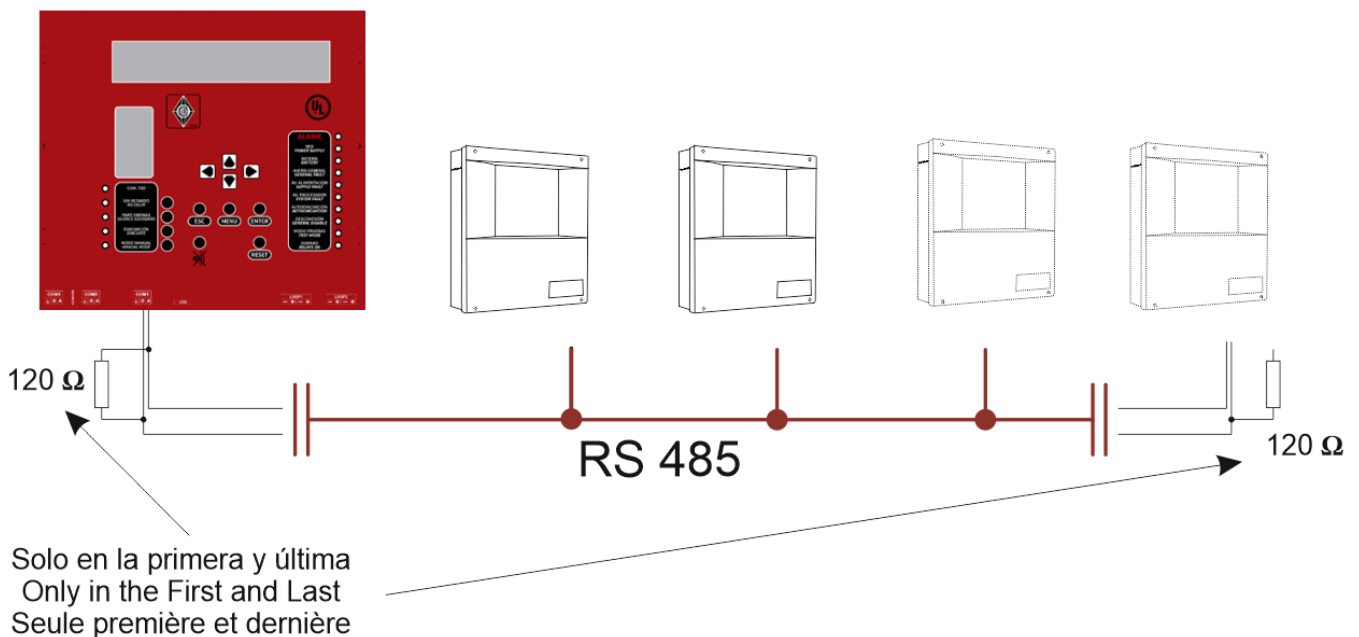

NOTE: Is due to connect a resistance of 120 ohms between the connectors A and B of the connected strip of the first an last control panel in network

Figure 18. Control panels network connection. Max 15

1.7- Accessories.

1.7.1- PC based configuration software.

Software is available for the digital control panel **Onix/Quartz (I-Link)**, that means of which the user can perform all the control panel programming in a simple and intuitive way. With this system it will be possible to maintain the configuration for future use.

2- Installation

2.1- Control panel installation.

The control panel must be assembled on a vertical face. The lateral grooves in the control panel must be left free for correct heat evacuation.

The dimensions and pre-drilling for the cable input are in the following figure.

Rectangular pre-drill "A" sited in the back of the control panel box must be against the wall if it is not used for cable input.

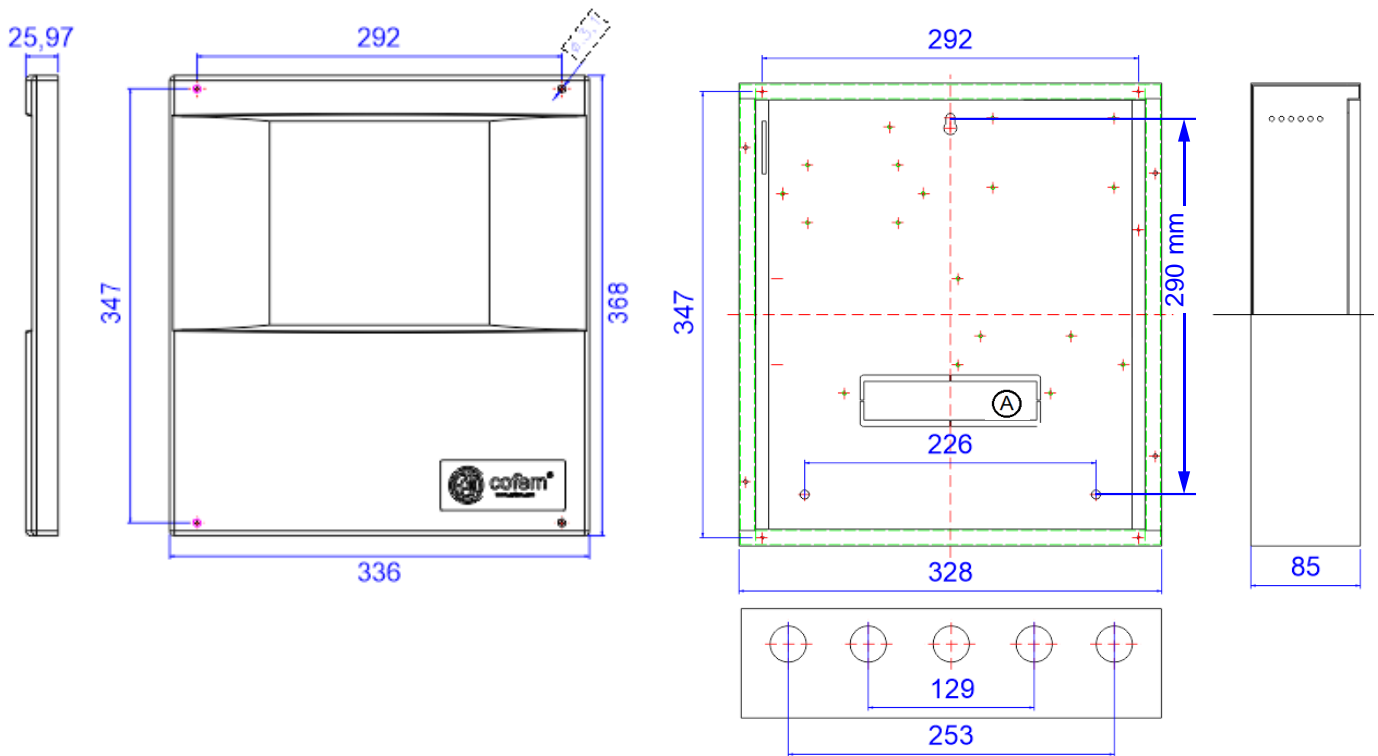

Figure 19. Control panel Onix/Quartz box

This equipment is not suitable for use in location where children are likely to be present.

Connection to the protective earthing of the building installation required.

In order to handle the Cover holder, care must be taken with the ground cable connecting one of its pin connected on the output circuit, and the connector of the CPU with the output circuit (See figure 29, end of the manual chapter 4).

Any connection or movement of the control panel must be carried out with the panel disconnected, both from the power supply, and from the batteries.

2.2- Onix/Quartz system connection

Connection of the digital system will be carried out with **2 x 1.5 mm BRAIDED CABLE SCREENED HALOGEN FREE**, both the loops as well as the sirens, KMA Y connected elements and failure outputs and 30 volt supplies.

Connection of the loop elements will be carried out in accordance with the schematics of corresponding technical sheets of each element

To avoid the dust entering in the sensors , wich may cause a performance degradation (A50S, A30SH or A50SHCOI), the red cover protector should be put on sensors while there is work on progress in that building.

Once is operational, all covers from all sensors **SHOULD BE REMOVED**, otherwise they will not work properly or not work at all.

A list should be made for each loop with the location, type and programming number of each element, this programming number goes from 1 to the 65533, see the example in the following table:

Loop: 01				
POINT	Programming no.	Label	Type	Notes
1	12757	ROOM 101	A50SH	
2	12432	ROOM 102	A50S	
3	4767	BUTTON P1	PUCAY	
4	6982	CORRIDOR P1	MDA1Y	
5	24222	ROOM 103	A50SHILD	
6	29529	CORRIDOR P1	A50SHI	

DISCONNECT the 110-230Vac voltage circuit before accessing the interior of the control panel , and then disconnect the batteries.

2.2.1- Electrical supply

Required Power supply is 65W, **110-230Vac ±10% at 50-60Hz**. Connection will be made by means of 3 strands with a minimum section of 1.5mm. Connection of the earth cable is obligatory.

Control panel must be electrically fed through a specific magnetothermic/differential switch specifically designate for fire detection and fire alarm system within the building with at least 10 A capacity. Control Panel doesn't have power switch. The switching on and off of the equipment will be perform through the building magnetothermic/differential switch and batteries connection.

An appropriate all-pole **mains** breaker, in accordance with *Annex L of IEC 62368-1 2nd Ed.* shall be provided as part of the building installation. Connection to the protective earthing of the building installation required.

For safety reason, electrical feed cable must be as short as possible inside the control panel. Then, electrical feed cable should enter control panel through the upper-left drill with the minimum length inside to allow well connection. See below drawing.

The electrical input connector has a fuse for safety in addition to the magnetothermic/differential switch or other safety device in the building.

ES3 sources are present within the product. With AC main connected only skilled person should open the enclosure for installation or service purposes, using insulated tools. Switching power supply is protected by a cover.

Fuses must be replaced by skilled personal only!

The replaceable fuses on the terminal input block and batteries (F1) are **FSF 5X20** series of 4A by Schurter.

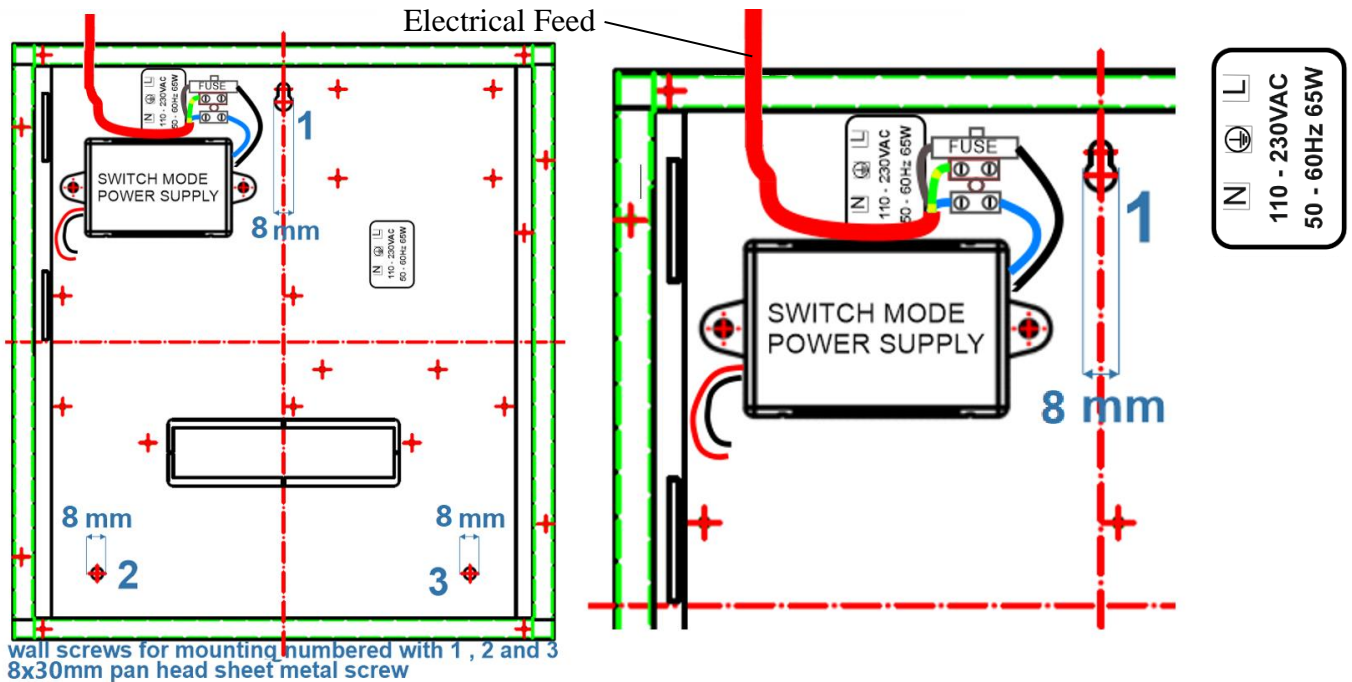

**WARNING! Live voltage inside (110-230Vac)!
Unplug the unit when manipulating live wires or main fuse!**

DISCONNECT the 110-230Vac voltage circuit before accessing the interior of the control panel , and then disconnect the batteries.

**Do not cut power to the control panel during the boot process.
Such action may cause permanent damage to the unit.**



2.2.2- Loop driver/ CPU LOGIC BOARD

The standard control panel can have a maximum of 2 loop drivers, located inside.

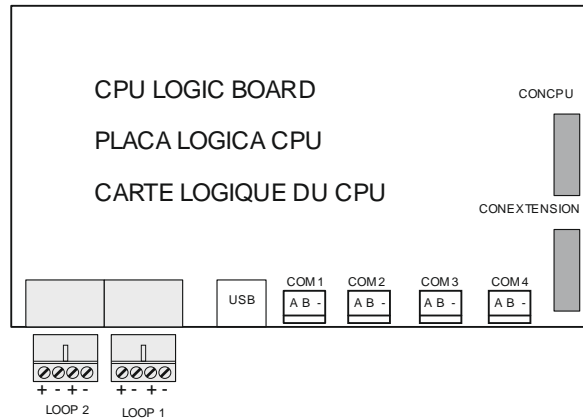

Figure 21. Loop driver/ CPU LOGIC BOARD

Each loop driver is numbered, to identify the corresponding loop. The numbering and the polarity come on the strip connector.

Connection of the loops of the Onix/Quartz digital system must be made with cable of 2 x 1.5 mm **BRAIDED SCREENED HALOGEN-FREE CABLE**.

Connection will be made according to Figure 24. General wiring diagram



DISCONNECT the 110-230Vac voltage circuit before accessing the interior of the control panel , and then disconnect the batteries.

2.2.3- Output card

- Power supply board:

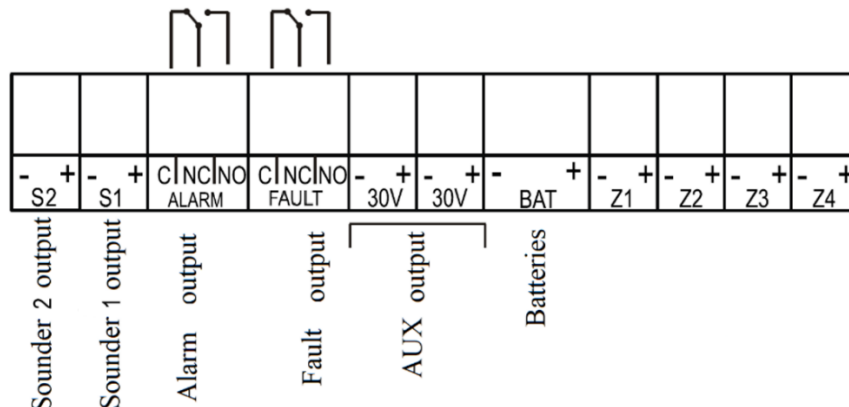

Electrical Input Connector	FUS	4A	Min Voltage	Max voltage
Batteries fuse	FUS	4A	21V	27,8V
30V total resettable fuse	Auto-resettable fuse	0,5 A	19V	30,5V
S1 sounder resettable fuse	Auto-resettable fuse	0,75 A	9,5V	30,5V
S2 sounder resettable fuse	Auto-resettable fuse	0,5 A	9,5V	30,5V
Loops	Auto-resettable fuse	0.5	19V	35V

Figure 22. Power output card

***Maximum output supply must be below than 1.6A including the sum of (S1 + S2 + AUX_output + LOOP_1 + LOOP_2)**

➤ **SOUNDER S1 & S2 output**

The output of sounders is independent, protected by means of a resetable fuse, to which a delay can be applied by means of the configuration menu, see 3 chapter configuration. The installation of sounders will be performed according to the schematic of **Figure 24**. It will be activated whenever an alarm occurs in the system and the programmed delay has passed. It is only deactivated when there is no alarm in the system or “Silence Sounders” led is activated.

➤ **ALARM Output**

No supervised, voltage-free output exit. It is activated whenever an alarm occurs in the system. It is only deactivated when there is no alarm in the system.

➤ **FAULT Output**

Non-monitored dry contact output, to which a delay can be applied by means of the configuration menu, see 3 chapter configuration. It will be activated whenever there is a fault in the system or not has power (the Common-Normally Open (NO) relay contact is shorted, indicating fault) and the programmed delay has passed. It is only deactivated when there is no fault in the system and the control panel is powered (the Common-Normally Open (NO) relay contact is electrically open).

➤ **Auxiliary 30V Resettable output**

It is an output with two pair terminals to make connections easier. This output is only cross-circuit supervised and protected by means of a resetable fuse (Note: The corresponding Cofem modules have feeding supervision and indication at control panel). Option to activate and deactivate. If activated, when a general rearm is issued, the Control Panel cut out the supply for 2 seconds approximately, to make sure that all devices are being reseted.

2.3- Components

2.3.1- Batteries

The supervised battery input/output allows the connection of batteries to the control panel. The batteries are charged through this connection as well as the monitoring of its status.

The battery charge is compensated depending on the temperature of the batteries. This input/output is protected by a fuse and also against inversion of polarity.

The capacity of the batteries that are incorporated into the control panel will depend on the number of loops and additional loads (e.g. relays modules), 7 Ah being the minimum recommended.

Connection of the two 12V batteries in series is exactly as indicated in **figure 23**.

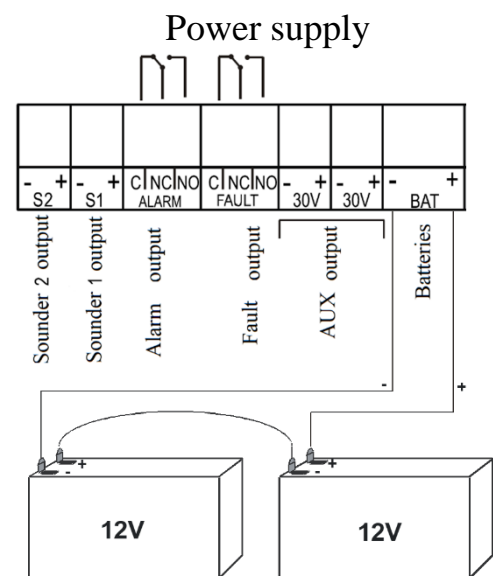

Figure 23: Battery connection diagram

Product could be connected or equipped with batteries only after to be evaluated as per Annex M of IEC 62368-1 2nd Ed. and only with batteries that comply with one of the following standards:

- | | | | | | | |
|-------------|--------------|--------------|--------------|--------------|-------------|-------------|
| IEC 60086-4 | IEC 60086-5 | IEC 60896-11 | IEC 60896-21 | IEC 60896-22 | IEC 61056-1 | IEC 61056-2 |
| IEC 61427 | IEC/TS 61430 | IEC 61434 | IEC 62133 | IEC 62281 | IEC 62485-2 | |

Batteries used in the product shall have a minimum operating temperature of 45°C. Battery used in the product shall provide a max 12Vdc. Weight of the product with batteries installed cannot exceed 7.5 Kg

2.3.2- Connection schematic of a typical loop.

Connection of the digital system will be made with wire from **2 x 0.8 up to 2 x 1.5 mm TWISTED AND SCREENED HALOGEN FREE** not only loops but also sounder and fault outputs and elements connected to the KMA Y and the 30V supplies.

NOTE: For specific details of how each element is to be connected, please see the relevant chapter.

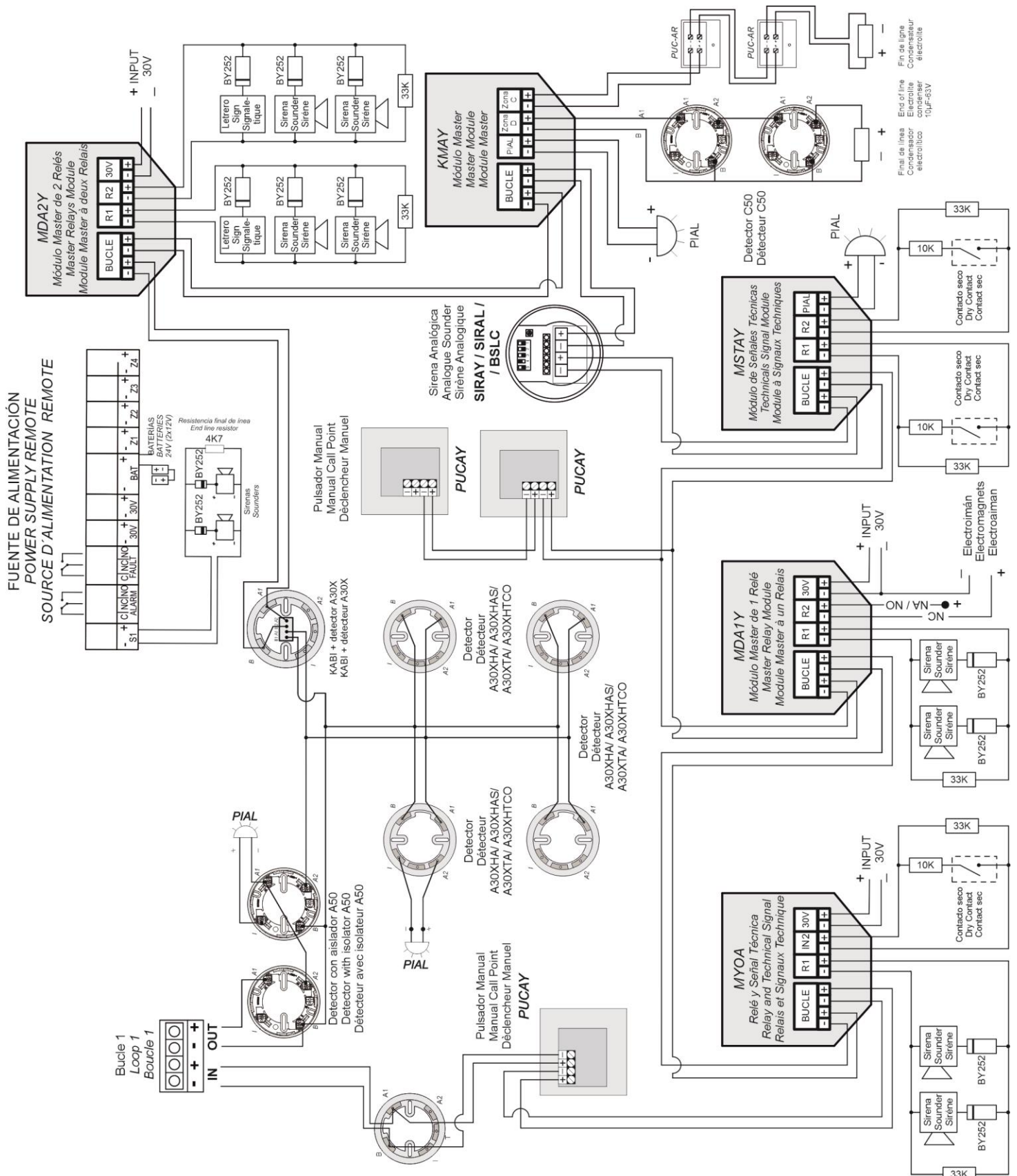

Figure 24 General Wiring Diagram

2.3.3- Sounder and controls with relays.

2.3.3.1- Connection of the internal two tone 24V Sounder (SIR-24B / SIR-24BL)

Elements needed for its correct installation:

- 1 Resistance 33 K Ω , in the event of being connected to the general sounder the resistance is 4K7, included in the control panel and/or modules.
- 1 Diode BY252, two diodes are included with each control panel .

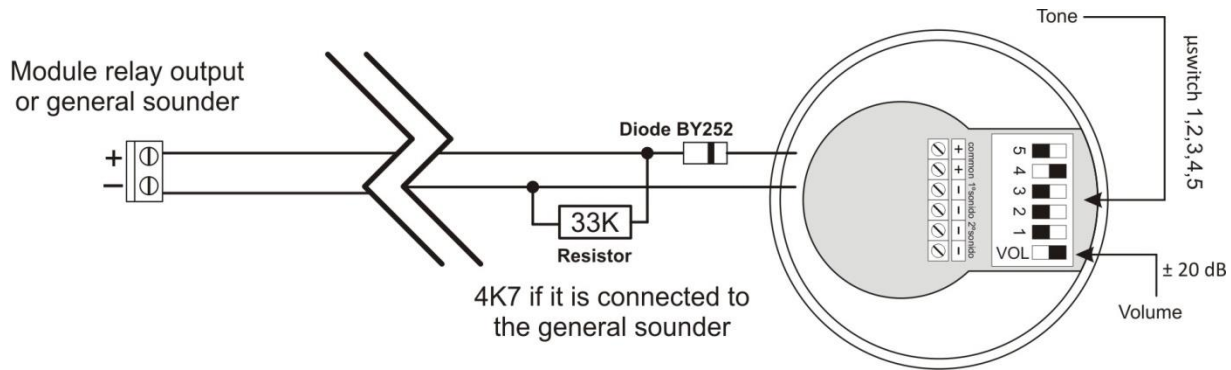

Figure 25. SIR-24B/BL connection schematic

NOTE!! An auxiliary 30V supply is necessary for KMAY32, MDA1Y, MDA2Y MYOA y MYOAF.

2.3.3.2- Connection of the non-flashing internal 24V Sounder (SIR24P)

Elements needed for its correct installation:

- 1 Resistance of 33 K Ω ; in the event of the sounder being connected to the general sounder, the resistance should be 4K7, which is included in the control panel and/or the modules.
- 1 BY252 Diode; two diodes are included with each control panel.

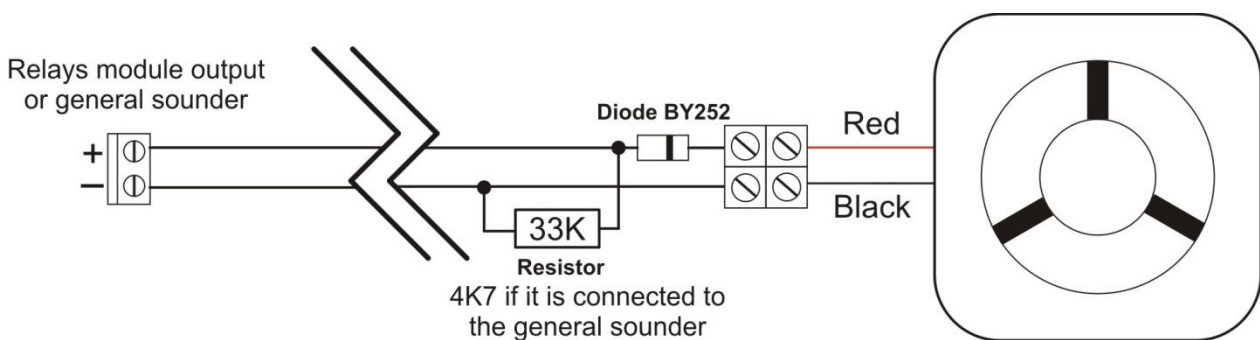

Figure 26. SIR24P Connection schematic

Modules KMAY32, MYOAF, MDA1Y and MDA2Y require an auxiliary 30V power supply

2.3.3.3- Connection of the flashing internal 24V Sounder (SIR24F)

Elements needed for its correct installation:

- 1 Resistance of 33 K Ω ; in the event of the sounder being connected to the general sounder, the resistance should be 4K7, which is included in the control panel and/or the modules.
- 1 BY252 Diode; two diodes are included with each control panel.

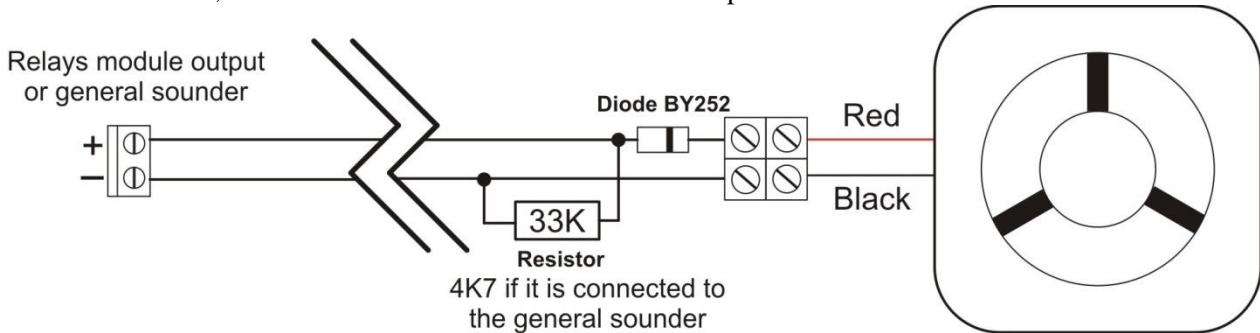

Figure 27. SIR24F Connection schematic

NOTE: An auxiliary 30 V supply is necessary for KMAY32, MYOAF, MDA1Y and MDA2Y modules

2.3.3.4.- External Siren 24V alarm box (CAEC)

- Red outdoor siren made of ABS plastic.
- Built-in back cover to protect all internal circuitry.
- They work as 24V power sirens.
- Piezoelectric speaker.
- Certified EN54-3 type B.



NOTE:

EOL: 33K Ω when connected to module

EOL: 4K7 when connected to the control panel

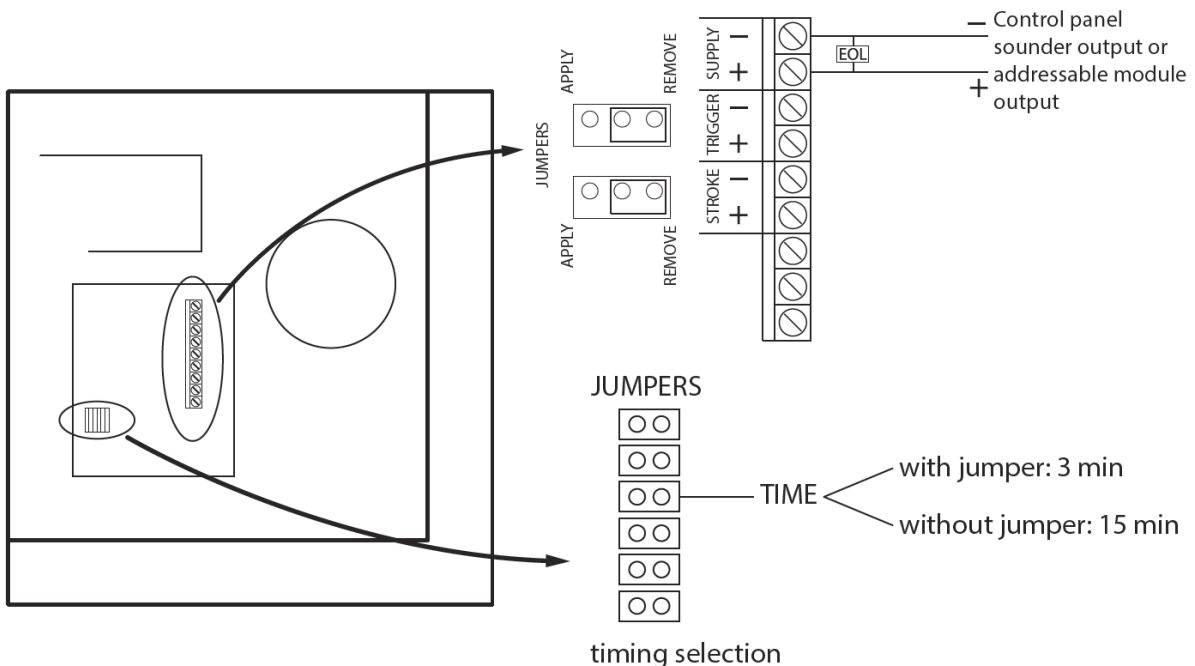

Figure 28. CAEC Connection schematic

2.4- Accessories.

2.4.1.- Computer.

The **Onix/Quartz Digital Control Panel** system can use software (I-Link), with which the user can completely programme the control panel, easily and intuitively. By using this system, the configuration can be saved for future use.

As shown in the diagram the connection between the PC and the control panel must be made using a USB 2.0 PORT.

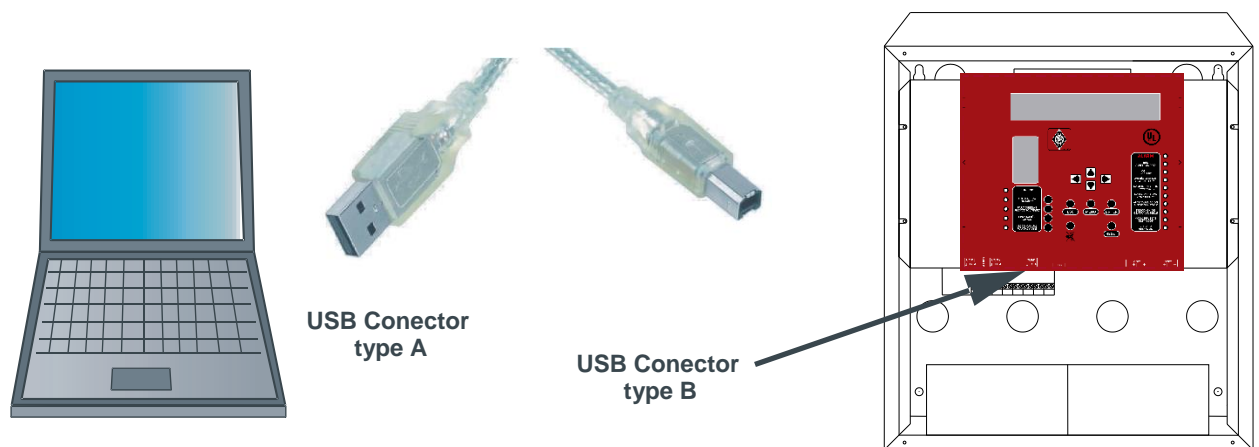

The connection to the USB port must be made using a cable no more than 3 metres long.

The use of the I-Link program and the configuration of the communication ports of the computer are described in the manual (Manual I-Link).

In the case of installing the functionality of I-Link ONLINE, uses RS485 connection as indicated in the control panel port (instead of using the USB connection).

This will avoid potential interference with communication and allows greater separation distances between control panel and PC.

The following figure shows examples of wiring.

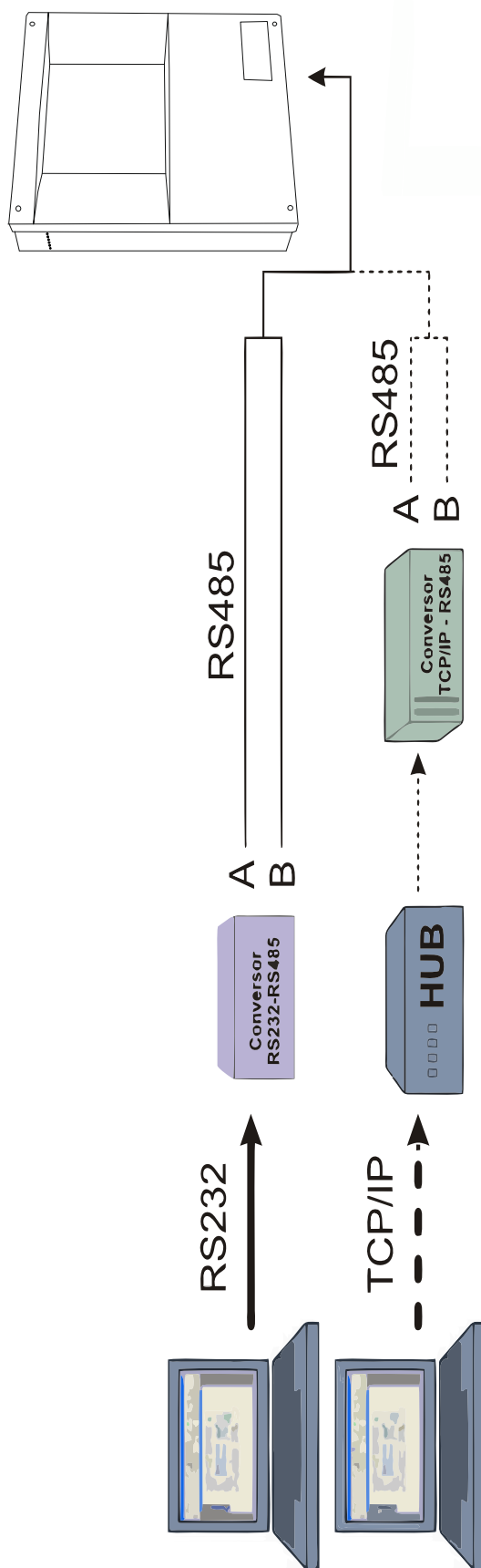

Example of PC (I-Link ONLINE) connection for long distances
(Through a RS232/RS485 converter or TCP/IP connection)

3- Operation and configuration.

3.1- Description of the front panel.

3.1.1- Keypad.



Disable the configured relay delays

Disable all relays that are configured as sirens.

Activate all relays programmed as sirens and switches.

Change to manual mode and disable all automatic relay activations.

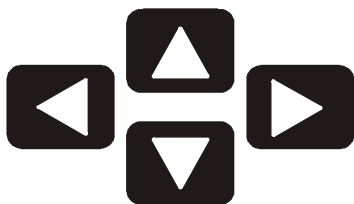

These cursors allow us to move through the menu that appears on the screen and to select characters in text mode.



ESC Key that enables the user to pass from one level to a higher level in the menu tree of the control panel and to cancel menu selections



MENU This key enables us to enter the control panel menu and to show the help text of the various menus.



ENTER This key enables us to confirm a selection.



SILENCE BUZZER



RESET Key that enables the user to reset events that have occurred in the system.

3.1.2.- Light indicators.

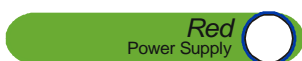

Green LED indicating that the system is working by means of the 110-230V network.



Green LED indicating that the system is working from the batteries. The POWER SUPPLY LED is off.



Amber LED indicating that the control panel is working in test mode or some zone is working mode.



Amber LED indicating a fault. The display details the type of supply fault.

Control panel menu:

>ONIX/QUARTZ

- 1. Monitoring
- 2. Logic relay activation
 - 2.1. List triggered Relays
 - 2.2. Turn on one Relay
 - 2.3. Turn off one Relay
 - 2.4. Activate all sounders
 - 2.5. Activate all operations
- 3. General relays
 - 3.1. General sounder relay
 - 3.1.1. Activate relay
 - 3.1.2. Stop relay
 - 3.1.3. Change delay
 - 3.1.4. Disable relay
 - 3.1.5. Enable relay
 - 3.2. Fault Relay
 - 3.2.1. Activate relay
 - 3.2.2. Stop relay
 - 3.2.3. Change delay
 - 3.2.4. Disable relay
 - 3.2.5. Enable relay
 - 3.3. 30V Output Rearming
 - 3.3.1. Activate
 - 3.3.2. Deactivate
- 4. System Setup
 - 4.1. Label points
 - 4.2. Configure
 - 4.2.1. Loop configuration
 - 4.2.1.1. Sensibility of a type
 - 4.2.1.2. Blink
 - 4.2.1.2.1. Blink enabled
 - 4.2.1.2.2. Blink disabled
 - 4.2.1.2.3. View setup
 - 4.2.1.3. Set up Loop Points
 - 4.2.1.3.1. View loop information
 - 4.2.1.3.2. Loop points Search
 - 4.2.1.3.3. Assign Point number
 - 4.2.1.3.4. Loop Automatic Configuration
 - 4.2.1.3.5. Delete Point
 - 4.2.1.3.6. Change point
 - 4.2.1.3.7. Delete Loop Points
 - 4.2.2. Logic In/out configuration
 - 4.2.2.1. Logic relays configuration
 - 4.2.2.1.1. Perform relay
 - 4.2.2.1.2. Delay
 - 4.2.2.1.3. Day-night
 - 4.2.2.1.3.1. Day programming call point
 - 4.2.2.1.3.2. Day sensor programming
 - 4.2.2.1.3.3. Night call point programming
 - 4.2.2.1.3.4. Night Sensor point programming
 - 4.2.2.1.4. Physical location
 - 4.2.2.1.5. Labelling
 - 4.2.2.1.6. Activation Mode
 - 4.2.2.1.6.1. General Activation
 - 4.2.2.1.6.2. General Network Activation
 - 4.2.2.1.6.3. Activation by List
 - 4.2.2.1.7. View setup
 - 4.2.2.1.8. View triggering lists
 - 4.2.2.2. Relay Auto. Configuration
 - 4.2.2.3. Delete Configured Relays

- 4.2.2.4. Mstay8 Input configuration
- 4.2.3. Configure alarm zones
 - 4.2.3.1. Configure zone
 - 4.2.3.2. List to Modify
 - 4.2.3.3. Delete zone
 - 4.2.3.4. Labelling
 - 4.2.3.5. View setup
- 4.2.4. Set up point sensitivity
- 4.2.5. Additional Passwords
 - 4.2.5.1. 2nd level password
 - 4.2.5.2. 3rd level password
- 4.2.6. Autoevacuation Setup
 - 4.2.6.1. Enable Autoevacuation
 - 4.2.6.2. Disable Autoevacuation
 - 4.2.6.3. Delay Setup
 - 4.2.6.4. Autoevacuation Summary
- 4.2.7. Added Delay Setup
- 4.2.8. Fast trigger Zone
- 4.2.9. **To Send Zones to Repeaters***
- 4.3. Set up time and date
 - 4.3.1. Change date
 - 4.3.2. Change time
- 4.4. Day/night timetable
 - 4.4.1. Day time start
 - 4.4.2. Day time end
 - 4.4.3. Set up Days Night Mode
 - 4.4.4. Delete programmed Night Mode
 - 4.4.5. Set up Summary
- 4.5. Swap test/normal
 - 4.5.1. Test mode
 - 4.5.1.1. General
 - 4.5.1.2. Zone Test
 - 4.5.2. Normal mode
 - 4.5.2.1. General
 - 4.5.2.2. Zone Test
 - 4.5.3. Zone List
- 4.6. Led ON/OFF
 - 4.6.1. Led ON
 - 4.6.2. Led OFF
- 4.7. Language menu
 - 4.7.1. Set language to Spanish
 - 4.7.2. Set language to English
 - 4.7.3. Set language to French
 - 4.7.4. Set language to Italy
 - 4.7.5. Set language to Hungarian
 - 4.7.6. Set language to Russian
 - 4.7.7. Set language to Portuguese
 - 4.7.8. Set language to Bulgarian
 - 4.7.9. Set language to Slovenian
 - 4.7.10. Set language to Slovak
 - 4.7.11. Set language to Turkish
 - 4.7.12. Set Romanian language
 - 4.7.13. Set language to Estonian
 - 4.7.14. Set language to Norwegian
 - 4.7.15. Set language to Dutch
- 4.8. Communications
 - 4.8.1. Repeater network
 - 4.8.1.1. View configured repeaters
 - 4.8.1.2. Configure repeaters
 - 4.8.1.3. Autodetect slaves
 - 4.8.1.4. Erase repeater
 - 4.8.1.5. Delete repeaters
 - 4.8.1.6. Label repeater
 - 4.8.2. **Control Panel Network***

- 4.8.2.1. View Control Panels
- 4.8.2.2. Reset control panel network
- 4.8.2.3. Network Keys Config
 - 4.8.2.3.1. Activate
 - 4.8.2.3.2. Deactivate
- 4.8.3. ContactID
 - 4.8.3.1. Activate
 - 4.8.3.2. Deactivate
 - 4.8.3.3. Test interval
 - 4.8.3.4. Phone 1 number programming
 - 4.8.3.5. Phone 2 number programming
 - 4.8.3.6. Phone 3 number programming
 - 4.8.3.7. Phone 4 number programming
 - 4.8.3.8. Phone 5 number programming
 - 4.8.3.9. Situation Message Programming
- 4.8.4 (Fire Alarm Center/Modbus) ***
- 4.8.5. Set Control Panel number
- 4.8.6. View Control Panel number
- 4.8.7. Communication mode-> (Com1/Com2/Com3/Com4/USB)
- 4.8.8. Consult Version
- 4.8.9. Remote connection
 - 4.8.9.1 Remote connection
 - 4.8.9.1.1 Activate
 - 4.8.9.1.2 Deactivate
 - 4.8.9.2 DHCP
 - 4.8.9.2.1 Activate
 - 4.8.9.2.2 Deactivate
 - 4.8.9.3 IP
 - 4.8.9.4 PORT
 - 4.8.9.5 MASK
 - 4.8.9.6 GATEWAY
 - 4.8.9.7 UMIP
 - 4.8.9.8 Serial Number
- 4.9. Sounder stop function
 - 4.9.1. Activation
 - 4.9.1.1. Continued
 - 4.9.1.2. Reset
 - 4.9.2. Performance
 - 4.9.2.1. Continued
 - 4.9.2.2. Event
 - 4.9.3. View setup
- 5. Enable/disable points/zones
 - 5.1. Enable point
 - 5.2. Disable point
 - 5.3. Enable zone
 - 5.4. Disable zone
 - 5.5. List disabled zones
 - 5.6. View Alarms by <Point/Zones>
- 6. System Test
- 7. Welcome message
- 8. General Rearm
- 9. Review history
 - 9.1. Review complete history
 - 9.2. Review alarms
 - 9.3. Review faults
 - 9.4. Review canceled
 - 9.5. Review relays

Fast tree menu. Example of use can be found at the end of the manual at :

“ Annex 2 – Elements configuration Rubi/Quartz/Onix ”

*Option 4.8.4 depending on version(Standard/Modbus/CRI) ;Rubi model only have 1 RS485 limited port.

3.2.1.- Level 1 access.

3.2.1.1.- Activation of the control panel.

- If the control panel is starting up correctly we see:

```

CDID Model
(C) Cofem, S.A.
Loading.....
    
```

V.x corresponds the version number of the control panel's software.

- The control panel is looking at the previous configuration data:

```

Recovering previous configuration
Zones: [ ]
Relays: [ ]
Updating System [ ]
    
```

- The control panel is performing an automatic element search:

```

Waiting Automatic Search .....
- - - - -
MODE 21 / 10 / 25
SEARCHING 20 : 29
    
```

- When the control panel reaches at this screen and it remains, this confirms to us that the control panel has been initialized correctly and that no alarms or faults of any type exist in the system. Only the green LED is illuminated (Power). It is also possible that other screens appear indicating anomalies of some type that are described in the following cases.

```

CDIC Model Cofem s.a.
- - - - -
MODE MODE 21 / 10 / 25
NIGHT AUTOMATIC 20 : 29
    
```

- Anomalies during start-up:**

- During the starting the possibility exists that memory I2C, where all the information keeps from the control panel, fails. In this case, we have two possibilities. One first that would allow us to reinitiate the configuration of the control panel being restored the values of factory (except labels of points and relays). Or one second, with that we could cancel the resumption of the configuration. If after to have reinitiated the control panel it returns to appear the message of "Failure I2C" it is that this one does not work correctly.

```

Failure I2C
The configuration will restart
Press ENTER to continue
Press ESC to cancel
    
```

- **Disabled zones and/or points**

In the case of disabling a elements or zone, the control panel will illuminate the orange DISABLED LED, sound the buzzer and show the following message:

CANCELED						TYPE :				
01 >	LABEL					POINT	CANCEL			
02	ZONE	01				ZONE	CANCEL			
								>>	01/02	

If the right cursor is pressed, we will be able to see the rest of the zone and/or element information.

						Unit	Loop	Point N°		
						↓	↓	↓		
CANCELED						C :	B :	P t :		
01 >	Z : 001	LABEL				01	01	001		
02	Z : 001	LABEL				-	-	-		
									<<	01/02

Selected disabled item N° disabled

- **Power supply faults**

If the control panel detects a power supply failure during some minutes, it will illuminate the amber GENERAL FAULT and SUPPLY FAULT LEDs, sound the buzzer and show the following message.

FAULTS						TYPE :				
01 >	SUPPLY CONTROL	11				EMPTY	BAT			
02	SUPPLY CONTROL	11				HIGH V	NET			
								>>	01/02	

WARNING: When there is no main power supply and the batteries supply are below 21 volts, the control panel shows the Empty Battery fault disabling all outputs, loops included, so no alarm or warning will be indicated, until main power supply is established.

Within supply faults, the following types of fault exist:

Type of Fault	Description
30V	Fault in the 30V output
NO BATTERY	Battery fault due to or absence of batteries
CHARGER FAULT	Battery charger fault
EMPTY BAT	Low Battery Voltage. Control Panel disconnects all outputs
BAT OVERCHARGED	Battery fault due to high Voltage level.
HIGH VOLTAGE	Network Voltage fault due to exceeding the level
LOW VOLTAGE	Network Voltage fault due to low level or absence of the same
BATTERY FAULT	Lifespan of batteries is over. Please change batteries.

- **Point fault**

If the control panel detects a fault in any of the elements, it will illuminate the amber GENERAL FAULT LED, sound the buzzer and show the following message.

FAULTS						TYPE :				
01 >	LABEL					PNT	NO ANSWER			
02 >	LABEL					OC	RELAY	02		
									>>	01/02

Relay number

If the right cursor is pressed we will be able to see the rest of the fault information.

F A U L T S										C :	B :	P t :
0 1 > Z :	0 0 1									0 1	0 1	0 0 1
0 2 > Z :	0 0 3									0 1	0 1	0 0 3
										> >	0 1 / 0 2	

Typical fail point messages are:

	Type of fault	Description
All elements	POINT NO REPLY	Communication fault with point.
A30XHA	DIRTY SENSOR	The A30XHA sensor has a dirty optical camera.
A30XHA-S	DIRTY SENSOR	The A30XHA-S sensor has a dirty optical camera.
A30XHTCO	DIRTY SENSOR	The A30XHTCO sensor has a dirty optical camera.
MDA1Y, MDA2Y, MYOA/F	SC RELAY (N°)	Short circuit in logical relay.
	OC RELAY (N°)	Open circuit in logical relay.
	24V RELAY (N°)	Absence of 24V in the relay module.
	RELAY NOT ACTIV.	It has not been possible to activate the relay.
MSTAY/8, MYOA	SC INPUT	Input short circuit
	OC INPUT	Input open circuit
Master modules KMAY	S. L. MASTER	Short circuit in the zone of the master module.
	O. L. MASTER	Open master circuit (the circuit is not closed with a line terminating 10uF/63V capacitor).
KMAY32	24V INPUT	Absence of 24V in the relay module.
	CROS LIN. MASTER	Short circuit in the zone of the master module
	OP. LINK MASTER	Open master circuit (the circuit is not closed with a line terminating 4k7 ohm resistor).
A50SI/L/D/LD	SC LOOP	The Isolated version of A50 series can report Short Circuit in the loop. The detectors can report the dirty sensor fault, except A50HL.
A50HI/L/D/LD		
A50SHI/L/D/LD		
A50HSCOI		

There must be elements with short-circuit isolator approximately every 32 elements for the proper detection of short-circuit faults by the control panel.

• **General sounders faults**

If the control panel detects a failure in the power supply to any of the two general sounder, it will illuminate the amber GENERAL FAILURE LED, sound the buzzer and show the following message.

F A U L T S										T Y P E :		
0 1 > S U P P L Y	C O N T R O L									A C	R E L A Y :	0 1
0 2 > S U P P L Y	C O N T R O L									O C	R E L A Y :	0 2
												0 1 / 0 2

Relay number

The relay number indicates to us, in this example, which of the two sounders is faulty (R1 shown as 01 and R3 as 03). Within general sounder faults, we have these types of fault:

Type of fault	Description
SC RELAY (N°)	Short circuit in the general sounder relay.
OC RELAY (N°)	Open circuit in the general sounder relay.

3.2.1.3- Moving through incidents.

Once the control panel has displayed any of the incidents described above, the user will be able to move among them using the “up and down” cursors and with the right cursor we will be able to see more information about the selected incident.

Incidents of the same type are always displayed on the screen in chronological order. On the screen, we have a maximum of two incidents. The incident that appears in the lower part of the screen is the last incident that has taken place and the incident in the upper part is the selected one, which we can change with the up and down cursors.

In order to change the type of incident on the screen we must press the ENTER key.

3.2.1.4- Look up incidents.

After viewing the incident that we wanted to look up, we press the right cursor to obtain in each case the corresponding screen with the rest of the incident information.

The next step, after viewing the incident and pressing the ENTER key, is to enter the level 2 access code. Once in level 2, we will press RESET and the control panel will enquire if we want to reset the incident.

The access code 2 will remain active for a few seconds. If we exit level 2 access and the time of authorisation at this level expires, it will be necessary to re-enter the corresponding code.

3.2.1.5.- Silence buzzer.



Key that enables the buzzer sound to be stopped after it has been activated by an incident. It is automatically reactivated for each new incident.

3.2.2. - Level 2 access.

3.2.2.1. - Access code

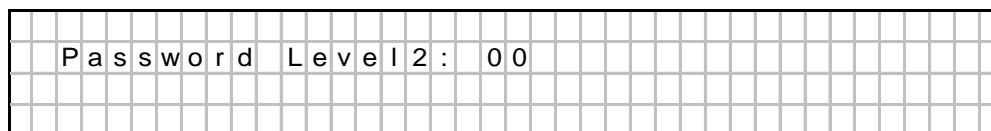

When pressing the menu key we access level 2 by means of a code (027). At this new level we will be able, among other things, to deactivate incidents, to put zones into service, to disable zones and to activate and deactivate relays.

3.2.2.2- Front panel keypad.



Disable configured relay delays.



Deactivate all relays that are configured as sirens.



Activate all relays programmed as sirens and switches.



Change to manual mode and disable all automatic activations of relays.



RESET

Key that enables the events generated in the system to be reset.

3.2.2.3- Reset events.

After any of the incidents previously described have been detected and the access code to level 2 has been entered, pressing the RESET key will deactivate these incidents, thereby resetting them.

If these incidents were faults, before resetting we must ensure that they have been corrected, otherwise they will re-appear on the screen.

3.2.2.4.- Monitor

Main

- 1. Monitoring**
- 2. Logic relay activation
- 3. General relays
- 4. System Setup
- 5. Enable/disable points/zones
- 6. System Test
- 7. Welcome message
- 8. General Rearm
- 9. Review history

It enables the readings and the configuration of the various addressable sensors to be seen. By entering the loop and elements numbers, we can see the type (optical, thermal, relays module, master module, etc), the label and the manufacturer's programming number. In the case of optical and thermal sensors we will also see the last five measurements.

Monitor message of an optical sensor:

LABEL						Type :	A50SI				
Loop :	001			Address :	001	N. Prog :	55826				
Values :	[000	000	000	000]	Temp :	025				
Dirt :	000%			Average :	000	Sensitiv :	MED				

In the case of a thermal sensor, the values are monitored in degrees.

LABEL						Type :	A50SHI				
Loop :	001			Address :	001	N. Prog :	55826				
Values :	[025	025	025	025]	Temp :	025				
Dirt :	- - -%			Average :	000	Sensitiv :	MED				

3.2.2.5.- Activate / Deactivate logical relays

- 2. Logic relay activation**
 - 2.1. List triggered Relays
 - 2.2. Turn on one Relay
 - 2.3. Turn off one Relay
 - 2.4. Activate all sounders
 - 2.5. Activate all operations

Exactly as they suggest, the submenus enable us to activate groups of relays configured as switches and sounders or make individual activations. Also there is the option to deactivate relays individually.

3.2.2.6.- Activate / Deactivate general relays

- 3. General relays**
 - 3.1. General sounder relay**
 - 3.1.1. Activate relay
 - 3.1.2. Stop relay
 - 3.1.3. Change delay
 - 3.1.4. Disable relay
 - 3.1.5. Enable relay
 - 3.2. Fault Relay
 - 3.2.1. Activate relay
 - 3.2.2. Stop relay
 - 3.2.3. Change delay
 - 3.2.4. Disable relay
 - 3.2.5. Enable relay
 - 3.3. 30V Output Rearming
 - 3.3.1. Activate
 - 3.3.2. Deactivate

Exactly as they suggest the submenus enable us to activate or deactivate the relay, to configure its delay between 0 and 9 minutes 59 seconds, and disabling or enabling the relay.

The "30V Output Rearming" function deactivates for approximately 2 seconds the output voltage to make sure that all modules are reset when a General Rearm of control Panel is issued.

3.2.2.7.- System configuration

4. System Setup
4.1. Label points
4.2. Configure
4.3. Set up time and date
4.4. Day/night timetable
4.5. Swap test/normal
4.6. Led ON/OFF
4.7. Language menu
4.8. Communications
4.9. Sounder stop function

Option 4 of the main menu, SYSTEM CONFIGURATION. From this option after entering the password for level 3 access we are able to access the configuration menu. **See chapter 3.2.3.-Level 3 access.**

3.2.2.8.- Enable/ Disable elements and zones

5. Enable/disable points/zones
5.1. Enable point
5.2. Disable point
5.3. Enable zone
5.4. Disable zone
5.5. List disabled zones
5.6. View Alarms by <Point/Zones>

Exactly as they suggest the submenus enable us to enable/disable zones or elements individually, and to view a list of the out of service zones. Option 5.6 allow to see on main display alarm grouped by points or zones.

3.2.2.9- System test

Main
1. Monitoring
2. Logic relay activation
3. General relays
4. System Setup
5. Enable/disable points/zones
6. System Test
7. Welcome message
8. General Rearm
9. Review history

Option 6 of the main menu, SYSTEM TEST. This is an option that allows us to perform a test of the control panel indicators. In this test all LED should be illuminated, the buzzer should sound and the following screen be shown:

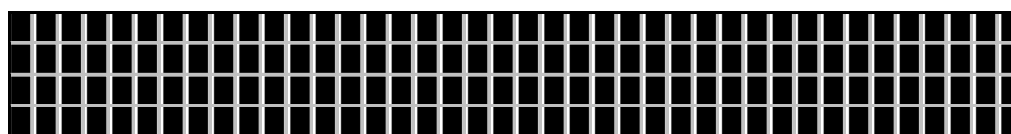

Type of event				Alarm type			
NUM: 003	ALARM	CALL POINT					
LOOP: 01	POINT: 005	N. Prog: 00001					
ZONE: 01	C. PANEL: 01	01/01/26	12:01				
LABEL:	B:1 P:5 NS:1						

- **Review faults:** This submenu is the same as the one to review the complete history except that is exclusively for fault.

Type of event				Fault type			
NUM: 003	FAULT	RELAY SC					
LOOP: 02	POINT: 003	N. Prog: 00003					
ZONE: 01	C. PANEL: 01	01/01/26	12:01				
LABEL:	B:2 P:3 NS:3						

- **Review disabled items:** This submenu is the same as the one to review the complete history except that is exclusively for disabled items.

Type of event				Diasabled type			
NUM: 001	DISABLED	DIS. ELEMENT					
LOOP: 01	POINT: 001	N. Prog: 00120					
ZONE: 01	C. PANEL: 01	01/01/26	12:01				
LABEL:	B:1 P:1 NS:120						

- **Review relays:** This submenu is the same as the one to review the complete history except that is exclusively for relays.

Type of event				Event type			
NUM: 004	ACTUATION001	SELF ACTIV					
LOOP: 03	POINT: 002	N. Prog: 00002					
ZONE: - -	C. PANEL: 01	01/01/26	12:01				
LABEL:	B:2 P:2 NS:2						

3.2.3- Level 3 access.

3.2.3.1- Access code

When entering the SYSTEM SETUP menu, we gain access to level 3 by means of a code (9000).From this menu we can configure the whole system.

4. System Setup

- 4.1. Label points
- 4.2. Configure
- 4.3. Set up time and date
- 4.4. Day/night timetable
- 4.5. Swap test/normal
- 4.6. Led ON/OFF
- 4.7. Language menu
- 4.8. Communications
- 4.9. Sounder stop function

3.2.3.2.- Label points.

Option 1 of the SYSTEM CONFIGURATION menu. We will have to introduce the loop and element number to label. This is an option that allows us to label each element of the system, that is to say, to give each point a description that gives us the information necessary to physically locate it in the installation. The label can have a maximum of 20 characters. This is the screen that appears during the labelling process:

ENTER	TEXT :																			
OFFICE	ZONE	1																		
MENU - > COPY RESET - > PASTE ENTER - > ACCEPT																				

3.2.3.3.- Configure

4.2. Configure
4.2.1. Loop configuration
4.2.2. Logic In/out configuration
4.2.3. Configure alarm zones
4.2.4. Set up point sensitivity
4.2.5. Additional Passwords
4.2.6. Autoevacuation Setup
4.2.7. Added Delay Setup
4.2.8. Fast trigger Zone
4.2.9. To Send Zones to Repeaters

Option 2 of the SYSTEM CONFIGURATION menu.

3.2.3.3.1. - Loop configuration

4.2.1. Loop configuration
4.2.1.1. Sensibility of a type
4.2.1.2. Blink
4.2.1.3. Set up Loop Points
4.2.1.4. Light/Sound A50xxLD

In this menu we have the possibility of configuring all the parameters related to the element of a loop such as: to assign the element numbers, to detect the elements, to configure sensitivity, etc.

Within the LOOP CONFIGURATION menu we have three important submenus that are:

- **SENSITIVITY OF A TYPE:** This submenu allows us to vary the sensitivity of all the sensors configured in the loop according to the type. Sensitivity has three levels HIGH, AVERAGE and LOW (all the sensors come with average sensitivity).
- **BLINK:** This submenu allows us to enable/disable the blinking leds of all the elements configured in the loop.
- **SET UP LOOP POINTS:** In this submenu we will be able to detect the elements that are connected to the loop and to assign a point number to them. Within this submenu we have seven submenus:

4.2.1.3. Set up Loop Points
4.2.1.3.1. View loop information
4.2.1.3.2. Loop points Search
4.2.1.3.3. Assign Point number
4.2.1.3.4. Loop Automatic Configuration
4.2.1.3.5. Delete Point
4.2.1.3.6. Change point
4.2.1.3.7. Delete Loop Points

- **VIEW LOOP INFORMATION:** In this submenu we can see the number of elements that are in the loop classified by type.

LOOP	:	01	A30XTA	:	000	KMAY	:	000
POINTS	:	005	A30XHA/S	:	000	MYOA	:	001
A50SHCOI	:	001	A30XHTCO	:	000	PUCAY	:	002
MSTAY/8	:	000	MDA1Y/2Y	:	000	SIRAY	:	001

- **LOOP POINTS SEARCH :** It detects elements in the installation and it shows a list the same as the one above.
- **ASSIGN POINT NUMBER:** To save the programming number of each point in the control panel. The programming number is the identification number that each elements has (from 1 to 65533 **and the same number may never be repeated in a loop**). The control panel must know this programming number to identify the elements.
- **LOOP AUTOMATIC CONFIGURATION:** Find the points of the loop and assigns a setup number to each point in order of programming numbers starting with the smallest.
- **DELETE POINT:** To delete a point that is no longer connected to the loop and is still configured, delete the programming number and the label of the element.
- **CHANGE POINT:** Replace one point in the loop by another. This is the appropriate option to replace an element since it saves the label. Take into account that it is necessary to first physically replace the element with the control panel disconnected, then start up the control panel and lastly run this menu option
- **DELETE LOOP POINTS:** To eliminate all the points configured in a loop both programming numbers and labels.
- **LIGHT/SOUND A50XXLD:** In this submenu we are able to configure A50XXLD sirens light and sound intensity. The control panel comes with HIGH level . It is configurable at loop level.

4.2.1.4. Light/Sound A50xxLD	
	4.2.1.4.1. Medium Level
	4.2.1.4.2. High Level
	4.2.1.4.3. View Setup

3.2.3.3.2- Logic In/out configuration

4.2.2. Logic In/out configuration	
	4.2.2.1. Logic relays configuration
	4.2.2.2. Relay Auto. Configuration
	4.2.2.3. Delete Configured Relays
	4.2.2.4. Mstay8 Input configuration

In this menu we find various utilities such as auto-configuring relays, modifying relay activation parameters, activation method, option to configure the list trigger, etc.

3.2.3.3.2.1- Configure logical relays

4.2.2.1. Logic relays configuration	
4.2.2.1.1.	Perform relay
4.2.2.1.2.	Delay
4.2.2.1.3.	Day/night
4.2.2.1.4.	Physical location
4.2.2.1.5.	Labeling
4.2.2.1.6.	Activation Mode
4.2.2.1.7.	View setup
4.2.2.1.8.	View triggering lists

Option 2 of the CONFIGURE menu. In this menu we have the option of configuring all the parameters referred to logical relays connected to the loop, that is to say, the type of actuation, delay, etc.

Within the CONFIGURE LOGICAL RELAYS menu we have eight submenus:

- **RELAY ACTUATION:** The relays can be configured as Sounders, Switches and relay.
 - **SOUNDERS:** these are activated automatically if they have been so configured and this is affected by the silence sounders button.
 - **MANOEUVRES:** these are activated automatically if they have been so configured and are not affected by the silence sounders button
 - **RELAY:** this is activated automatically and neither the evacuation nor the silence sounders keys affect it.
 - **SIRDR:** Activated automatically depending on configurations (example, delay, etc). It is affected by the key "Silence Sounders". It allows the activation of the base with light/sound A30XZSLDR / A30XZSDDR or A50ZSLDR/A50ZADDR.
- **DELAY:** The time period within which the necessary alarms are generated in order for a logical relay to be activated and the actuation of the same. A delay of between 0 and 9 minutes 59 seconds is possible.
- **DAY/ NIGHT:** In this submenu we can configure the type of activation of a logical relay (active with or without delay, inactive) for a daytime and night schedule. We will be able to activate the day mode independently for every day of the week.

4.2.2.1.3. Day/night

4.2.2.1.3.1.	Day programming call point	Inactive/Immediate/Delayed
4.2.2.1.3.2.	Day sensor programming	Inactive/Immediate/Delayed
4.2.2.1.3.3.	Night call point programming	Inactive/Immediate/Delayed
4.2.2.1.3.4.	Night call Sensor programming	Inactive/Immediate/Delayed

- **PHYSICAL SITUATION:** Loop and point number where the logical relay is.
- **LABEL:** To introduce a description of the relay for its identification in the installation.
- **ACTIVATION MODE:** Within this menu we find two options: General Activation and Activation by List.

4.2.2.1.6. Activation Mode

4.2.2.1.6.1.	General Activation
4.2.2.1.6.2.	General Network Activation**
4.2.2.1.6.3.	Activation by List

- **GENERAL ACTIVATION:** This option causes the relay to activate when an alarm occurs in any element of the control panel.
- **GENERAL NETWORK ACTIVATION:** This option causes the relay to activate when an alarm occurs in any control panel in the control panel network.
- **ACTIVATION BY LIST:** This option allows you to relate the trip of a relay to a list of points that belong to any of the control panels and loops that make up the system. The point list is made up of up to 8 lines called sub-lists. Each sub-list includes all the correlative elements of the specified control panel and loop, from the starting point to the ending point (and both points included). The sub-list allows defining the number of elements in this sub-list that must be in an alarm state to be activated through the "alarms" parameter. Selecting 1, 2 or 3, there must be this number of elements in the sub-list to trigger the relay. The existence of a sub-list makes it possible to relate the trip

of a relay to different points located in different loops and centers within the system. Furthermore, the sub-lists are related to each other by the logical command AND (&) and OR (/). The AND (&) command means that the trigger conditions of that sub-list must be given with that of the next one. The OR (/) command means that the trigger conditions of that sub-list must be given "or" that of the next one.

Below are some examples.

• **Case 1:**

	Relay Number	Loop number	First point	Last point
RELAY: 1	LABEL:			
1 CTRL: 01	LOOP: 01	ALRM: 3	PNTS: 001: 009	/
2 CTRL: 00	LOOP: 00	ALRM: 0	PNTS: 000: 000	/
3 CTRL: 00	LOOP: 00	ALRM: 0	PNTS: 000: 000	/

↑ List (sub-list) ↑ Control_Panel ↑ Alarms ↑ Logic (OR , AND)

In this case, relay 01 will be activated when there are more than 3 sensors in alarm state from 9 sensors that are present in the LOOP_01 in Control_Panel_01

• **Case 2:**

RELAY: 1	LABEL:			
1 CTRL: 01	LOOP: 01	ALRM: 1	PNTS: 001: 001	&
2 CTRL: 00	LOOP: 00	ALRM: 1	PNTS: 005: 005	&
3 CTRL: 00	LOOP: 00	ALRM: 0	PNTS: 009: 009	/

In this case the RELAY_01 will be activated by Control_Panel_01 from LOOP_01 when sensor 1,5 and 9 are all of them in alarm state, and our relay may be in that loop or another.

Very important to notice is the logic operator “OR” that should ALWAYS be at the end of any list (sub-list), otherwise the relay 01 will never be activated.

• **Case 3:**

RELAY: 1	LABEL:			
1 CTRL: 01	LOOP: 01	ALRM: 1	PNTS: 001: 001	&
2 CTRL: 02	LOOP: 01	ALRM: 1	PNTS: 005: 005	&
3 CTRL: 03	LOOP: 01	ALRM: 1	PNTS: 009: 009	/

In this last scenario, the “RELAY 1” will be activated only when all 3 sensors defined in different Control_Panels in network are in alarm state.

- **VIEW CONFIGURATION:** View the configuration of the relay and all its parameters.

RELAY: Relay Maneuver	Relay	002
MDA2Y Maneuver	Loop: 002	Point: 003
DAY Detector: Yes	Call: Yes	Delay: 00
NIGHT Detector: Yes	Call: Yes	

- **VIEW DELAY LISTS:** View the list of points configured for the relay.

***NOTE: Case 3 only for ONIX/QUARTZ**

3.2.3.3.2.2.- Relay Auto. Configuration

4.	System Setup
4.1.	Label points
4.2.	Configure
4.2.1.	Loop configuration
4.2.2.	Logic In/out configuration
4.2.2.1.	Logic relays configuration
4.2.2.2.	Relay Auto. Configuration
4.2.2.3.	Delete Configured Relays
4.2.2.4.	Mstay8 Input configuration

Option that configures all relays automatically (all types like SIRAY, MDA1Y, MDA2Y , MYOA/F and A50XXLD) except SIRDR, as immediate ALARM. This option overrides the previous relay configurations.

3.2.3.3.2.3.- Delete Configured Relays

4.2.2.	Logic In/out configuration
4.2.2.1.	Logic relays configuration
4.2.2.2.	Relay Auto. Configuration
4.2.2.3.	Delete Configured Relays
4.2.2.4.	Mstay8 Input configuration

Option that **CLEARs ALL CONFIGURED** relays from the loop.

3.2.3.3.3.- Configure alarm zones.

4.2.	Configure
4.2.1.	Loop configuration
4.2.2.	Logic In/out configuration
4.2.3.	Configure alarm zones
4.2.4.	Set up point sensitivity
4.2.5.	Additional Passwords
4.2.6.	Autoevacuation Setup
4.2.7.	Added Delay Setup
4.2.8.	Fast trigger Zone
4.2.9.	To Send Zones to Repeaters

In this menu we have the option of configuring the various alarm zones into which we will divide the points of the control panel. When an alarm zone is configured, it is not permissible to include a point in two different alarm zones. Each zone must be delimited by an isolated element at beginning and the end.

Within this menu we have five submenus:

4.2.3.	Configure alarm zones
4.2.3.1.	Configure zone
4.2.3.2.	List to Modify
4.2.3.3.	Delete zone
4.2.3.4.	Labeling
4.2.3.5.	View setup

- **CONFIGURE ZONE:** The control panel will request the loop number, the first and last consecutive element included in the alarm zone list. We will be able to introduce 8 lists into each alarm zone.
- **MODIFY LISTS:** This option allows us to modify one of the alarm zone lists.
- **DELETE ZONE:** The zone configuration is deleted.
- **LABEL:** This provides a description of the zone with a maximum of 20 characters for its identification in the installation.
- **VIEW CONFIGURATION:** To view the list of points that are included in the alarm zone.

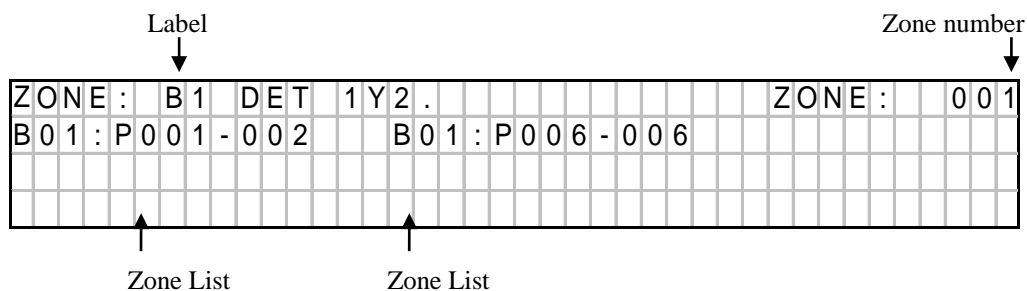

3.2.3.3.4.- Configure element sensitivity

4.2. Configure
4.2.1. Loop configuration
4.2.2. Logic In/out configuration
4.2.3. Configure alarm zones
4.2.4. Set up point sensitivity
4.2.5. Additional Passwords
4.2.6. Autoevacuation Setup
4.2.7. Added Delay Setup
4.2.8. Fast trigger Zone
4.2.9. To Send Zones to Repeaters

From this menu we can vary the sensitivity of the points individually (indicating the loop and point number). There are three levels of sensitivity: HIGH, MEDIUM AND LOW (all the sensors come with average sensitivity).

3.2.3.3.5.- Additional passwords

4.2.5. Additional Passwords	
4.2.5.1. 2nd level password	"27"
4.2.5.2. 3rd level password	"9000"

From this menu we can introduce an additional password for the access level 2 and another one for the access level 3, included the numbers 00 and 0000. Whenever we introduce a new password it deletes the one that had been previously entered. The standard Passwords that the control panel have are: access level 2: **27**; and access level 3: **9000**).

3.2.3.3.6.- Configure auto-evacuation

4.2.6. Autoevacuation Setup
4.2.6.1. Enable Autoevacuation
4.2.6.2. Disable Autoevacuation
4.2.6.3. Delay Setup
4.2.6.4. Autoevacuation Summary

Within this menu we have four submenus: ENABLE AUTOEV., DISABLE AUTOEV., CONFIGURE DELAY and AUTO EVACUATION SUMMARY. Automatic evacuation is a function that activates the relays configured as sounder and/or switches if there is an alarm in the system and the alarm has not been reset during the configured delay.

- **ENABLE AUTOEV.:** Automatic evacuation is activated by this option.
- **DISABLE AUTOEV.:** Automatic evacuation is deactivated by this option.
- **CONFIGURE DELAY:** The delay period that occurs between the alarm being raised and the siren and/or switch relays being activated is configured with this option. The maximum delay is 9 minutes and 59 seconds.
- **AUTO EVACUATION SUMMARY:** In this option we will be able to see the status of automatic evacuation and its delay.

3.2.3.3.7- Added Delay Setup

4.2.7. Added Delay Setup

This option is activated when it is introduced a time between 1" to 9 min 59".

When the **first** signal alarm is received, control panel activates corresponding programmed **delays**.

If operator press "**Silence Buzzer**" before programmed delay time is finished, all the relays (including the sounder relay output in control panel) are additionally delayed with the value "**Additional delay**". In this way, operator is allowed to investigate alarm.

If at any time during the delays a **second alarm** occurs (without the need to press the stop buzzer) in the control panel, all the relays associated with the elements of alarm are **triggered immediately**.

3.2.3.3.8- Fast Trigger Zone

4.2.8. Fast trigger Zone

The alarm signal input of any element defined in the zone introduced in this option makes immediately activation of all control panel relays.

3.2.3.3.9- Send Zones to Repeaters

4.2.9. To Send Zones to Repeaters

This option allows sending the configured zones to the repeaters, if not executed the repeaters will only indicate the label of the point.

3.2.3.4- Update date and time

4.3. Set up time and date

- 4.3.1. Change date
- 4.3.2. Change time

Within this menu we have two options, CHANGE DATE and CHANGE TIME. With the cursors we will be able to update the fields for both options.

3.2.3.5.- Day/ Night timetable

4.4. Day/night timetable

- 4.4.1. Day time start
- 4.4.2. Day time end
- 4.4.3. Set up Days Night Mode
- 4.4.4. Delete programmed Night Mode
- 4.4.5. Set up Summary

The day/night mode serves to configure the activations of relays since they can have a different operation for day and night. The day mode can be activated or deactivated independently for the different days of the week.

- DAY TIME START: The control panel will request the start time for the day mode.
- DAY TIME END: The control panel will request the end time for the day mode.
- PROG. NIGHT MODE DAYS: This option allows us to configure the control panel night mode for the whole 24 hours of a day.
- DELETE NIGHT MODE PROG.: This option deletes the configuration described in the previous paragraph
- PROGRAMMING SUMMARY: This option shows the configuration of the night/day mode of the control panel.

3.2.3.6.- Put into test/ normal mode

4.5. Swap test/normal

4.5.1. Test mode

4.5.2. Normal mode

4.5.3. Zone List

Test mode is the operating mode that allows us to activate the alarm of any control panel element without any of the configured relays activating. In addition all the alarms will reset automatically after 15 seconds. This mode is appropriate for performing tests and system maintenance.

4.5. Swap test/normal

4.5.1. Test mode

4.5.1.1. General

4.5.1.2. Zone Test

4.5.2. Normal mode

4.5.2.1. General

4.5.2.2. Zone Test

4.5.3. Zone List

- TEST MODE: Within this menu we have two options: we will be able to activate test mode generally or by alarm zone.
- NORMAL MODE: Within this menu we have two options: we will be able to activate normal mode generally or by alarm zone.
- LIST ZONES: This option shows us the operating mode of the control panel and the alarm zones.

3.2.3.7- Led ON / OFF

4.6. Led ON/OFF

4.6.1. Led ON

4.6.2. Led OFF

This is option 6 of the SYSTEM CONFIGURATION menu. This menu allows activation or desactivation (If it is already activated) the led of one element of the loop. This functionality is activated if the element is inside a zone in test mode.

3.2.3.8.- Language menu

4.7. Language menu

- 4.7.1. Set language to Spanish
- 4.7.2. Set language to English
- 4.7.3. Set language to French
- 4.7.4. Set language to Italy
- 4.7.5. Set language to Hungarian
- 4.7.6. Set language to Russian
- 4.7.7. Set language to Portuguese
- 4.7.8. Set language to Bulgarian
- 4.7.9. Set language to Slovenian
- 4.7.10. Set language to Slovak
- 4.7.11. Set language to Turkish
- 4.7.12. Set Romanian language
- 4.7.13. Set language to Estonian
- 4.7.14. Set language to Norwegian
- 4.7.15. Set language to Dutch

From this menu the language of the control panel is selected. The control panel will be provided with seven languages as standard: Spanish, English, French, Italian, Hungarian, Russian Ukrainian, Portuguese, etc.

NOTE: The auto configuration function of the loop sets the default labels in the language the control panel is in that moment. If the language is changed, the labels do not change.

3.2.3.9.- Communications

4.8. Communications
4.8.1. Repeater network
4.8.2. Control Panel Network
4.8.3. Contact ID
4.8.4. F.A.C/ModBus Protocol
4.8.5. Set Control Panel Number
4.8.6. View Control Panel Number
4.8.7. Communication mode -> (Com1/Com2/Com3/Com4/USB)
4.8.8. Consult Version
4.8.9. Remote connection

Option 8 of the SYSTEM CONFIGURATION menu. Within this menu we have following submenus:

4.8.1. Repeater network
4.8.1.1 View configured repeaters
4.8.1.2 Configure Repeaters
4.8.1.3 Autodetect slaves
4.8.1.4 Erase repeater
4.8.1.5 Delete repeaters
4.8.1.6 Label Repeater

- REPEATER NETWORK:

- VIEW CONFIGURED REPEATERS: display the configured repeaters on the control panel.
- CONFIGURE REPEATERS: Give the address of the repeaters with which it is desired to communicate.
- AUTO-DETECT SLAVES: In this menu the connected repeaters are detected and the control panel will automatically communicate with these repeaters.
- ERASE REPEATER: From this option the selected repeater is deleted.
- DELETE REPEATERS: From this option, all the repeaters configured in the control panel are deleted.
- LABEL REPEATER: In this menu we give a label to the repeater with a maximum of 20 characters.

4.8.2. Control Panel Network
4.8.2.1 See Control Panels
4.8.2.2 Reset control panel network
4.8.2.3 Network Keys Config

- CONTROL PANEL NETWORK:

- SEE CONTROL PANELS: Visualize the configured control panels.
- RESET CONTROL PANEL NETWORK: Reset all the control panels connected to a network.

4.8.2.3 Network Keys Config
4.8.2.3.1 Activate
4.8.2.3.2 Deactivate

- NETWORK KEYS CONFIG: Allow to Activate/Deactivate the keys (No Delay, Silence Sounders, evacuate, Manual Mode, Buzzer) automatically when this option is enabled in other/s control panels connected to network.

- CONFIGURE CONTROL PANEL NUMBER:

- SET CONTROL PANEL NUMBER.

4.8.5. Set Control Panel number
--

- CONTROL PANEL NUMBER:

- VIEW THE CONTROL PANEL NUMBER.

4.8.6. View Control Panel number

• TYPE OF PC COMMUNICATION:

- The communication ports of the control panel are configurable with the different available functionalities. The control panel has 4 RS485 communications ports identified as COM1, COM2, COM3, COM4 and a USB port identified as USB1.

In this menu you can select the port you want to use with the following features:

- NeTW: Connection port for connecting control panels in main network line.
- NeTW2: Connection port for connecting control panels in back-up network line.
- RePT: Connection port for connecting repeater.
- iLNK: Connection port for control panel software configuration I-Link or I-Link ONLINE.
- CRI: Connection for Fire Alarm Receiving Centre card.
- ReMT: Connection port for REMOTE card.
- F.A.C/ModBus : Only special versions on demand, Fire Alarm Center or Modbus control.

4.8.7. Communication mode -> (Com1/Com2/Com3/Com4/USB)																																			
C	o	m	m	u	n	i	c	a	t	i	o	n	m	o	d	e																			
C	O	M	1	:	-	-	-						C	O	M	2	:	-	-	-					C	O	M	3	:	-	-	-			
C	O	M	4	:	-	-	-						U	S	B	1	:	-	-	-					<	L	E	F	T	/	R	G	H	T	>
E	N	T	E	R	:	S	A	V	E	,			O	P	T	I	O	N	S	:	U	P	-	D	W	N	,	E	S	C	:	O	U	T	

- REMOTE CONECTION: It allows configuring the following communication parameters of the REMOTE card in the Ethernet network.
 - Activate/Deactivate the communication with the REMOTE CARD.
 - DHCP: Activate or deactivate DHCP option. Whether is activated or deactivated the remote card need to be restarted. DHCP configuration will overwrite user settings (IP, MASK, etc.)
 - IP: Defines the IP address of the REMOTE card in the internal network. By default 192.168.0.254.
 - PORT: Defines the port of the REMOTE card. The server / router must be configured to allow communication between the REMOTE card and the external network. By default the value is 80.
 - MASK: Mask of the server / router that differentiates the IP addresses of the internal and external network. Based on the IP address of the server / router, the "0" values identify the internal addresses. By default, the value of the mask is 255.255.255.0.
 - GATEWAY: IP address of the server / router. By default the value is 192.168.0.50.
 - UMIP: Acronym for "Update My IP". With the activation of this function, it is allowed to communicate with the REMOTE card of the central from the web "www.l-remote.com" automatically without needing to know the IP address of the server / router.

- SERIAL NUMBER: It is the serial number of the REMOTE card needed to identify it on the web "www.l-remote.com".

4.8.9. Remote connection

- 4.8.9.1 Remote connection
 - 4.8.9.1.1 Activate
 - 4.8.9.1.2 Deactivate
- 4.8.9.2 DHCP
 - 4.8.9.2.1 Activate
 - 4.8.9.2.2 Deactivate
- 4.8.9.3 IP
- 4.8.9.4 PORT
- 4.8.9.5 MASK
- 4.8.9.6 GATEWAY
- 4.8.9.7 UMIP
- 4.8.9.8 Serial Number

3.2.3.10.- Stop Sounder Function

Within this menu we have the following options:

4.9. Sounder stop function

- 4.9.1. Activation
 - 4.9.1.1. Continued
 - 4.9.1.2. Reset
- 4.9.2. Performance
 - 4.9.2.1. Continued
 - 4.9.2.2. Event
- 4.9.3. View setup

- ACTIVATION:
 - CONTINUOUS: "Stop Sounder" continues active after re-start up of the control panel.
 - RESET: "Stop Sounder" is automatically deactivated after re-start up of the control panel.
- PERFORMANCE:
 - CONTINUOUS: "Stop Sounders" continues active although new signal alarm arrives to control panel.
 - EVENT: "Stop Sounders" is deactivated when new signal alarm is received to control panel.
- VIEW SET UP: It is shown selection of "ACTIVATION" and "PERFORMANCE".

4- Set-up.

4.1- Prior verifications.

Prior to putting the *ONIX/QUARTZ digital system* installation into operation, we must assure ourselves that the installation is totally completed and we have all the data for its correct programming.

For this it is necessary to verify that the points shown below have been completed:

- To have a 110-230V power source available dedicated to the fire protection system and that it is live 24 hours a day, seven days a week. (see chapter 2.1)
- To have a set of two 12V batteries connected to the control panel.
- To verify that all the elements are connected to the installation.
- To verify that there are no installation elements left unconnected or with connection errors that could cause faults when putting into operation or deterioration of the ONIX/QUARTZ digital system elements.
- Do not remove the covers until the installation is finished and clean.
- To have a list with the total of connected elements of each type in each loop, see example in the following table.

LOOP: 1	
TYPE	AMOUNT
A50SHI	15
A50S	2
A50H	5
PUCAY	10
SIRAY	1
MDAxY	6
MSTAY	1
KMAY	3
MYOA	1
TOTAL	44

- To have a list for each loop with the location, type and programming number of each element, (sensor, button, relay module, technical signals module, addressable sirens, master module). This programming number goes from 1 to 65533, see example in the following table:

Loop: 01				
POINT	Prog. No.	Label	Type	Notes
1	12757	ROOM 101	A50SH	
2	12432	ROOM 102	A50SH	
3	4767	BUTTON P1	PUCAY	
4	6982	CORRIDOR P1	KMAY	

In this way with the lists made on-site, that are completed with the listings of relay activation and with the relationship of alarm zones, it is possible to undertake the system programming working with the control panel's own keypad or much more easily using the **I-Link** program on a PC that will later download to the control panel.

4.2- Supply.



WARNING! Live voltage inside (110-230Vac)!
Unplug the unit when manipulating live wires or main fuse!
The power to the input terminals is 110-230Vac and 50-60 Hz !



Attention: Connect the EARTH cable, ensuring that the positions of the neutral line and phase are correct

BATTERIES: Connect the two elements in series (**Watch out for the polarity**). When power supply is on the voltage battery terminals should be between 24 and 27 V DC.

The 110-230V power supply will be connected to the *control panel* and then the batteries. The green power supply LED on the front of the control panel must light and the initialization texts must be seen as indicated in section 3.2.1.1.

4.3- Loops and relays

The loops will be put into operation one by one. Once the loop cables are connected to the corresponding driver, proceed with the element search as described in section 3.2.3.3.1. “**Loop configuration**”.

When the search is completed check the number of elements found by the control panel against the data taken previously, see section 4.1.

- If the number found is the same, it means that all the elements are correctly connected to the *Control Panel System* loop.
- If the number found is higher it means that there must be more elements installed in the loop. You must update the information about them - programming numbers, labels - to be able to complete the putting on operation.
- If the number found is lower, it means that fewer elements have been installed in the loop; there are unconnected or not assembled loop elements. Review the whole loop installation reviewing all the connections and counting the installed elements.

Once all problems in the system have been solved, the loop element search must be repeated. If a correct result is obtained (the expected number of elements in the loop), the entire process described above can be repeated for another loop.

Next, one must proceed with the allocation of previously chosen programming numbers to the loop elements, see section 4.1.

Also a name can be assigned to each loop element, called a label. It can be done from the control panel keys, (see section 3.2.3.2 “**4.1 Label Points**” , Annex_2 or I-Link Manual).

If the control panel has relay modules (MDA1Y, MDA2Y and MYOA) and loop sounders (SIRAY/SIRAYL), one will proceed to the configuration of such depending on the elements that must activate them, from the control panel keys, (see section, 3.2.3.3.2 “**4.2.2 Logic in/out configuration**” Annex 2 or I-Link Manual).

There is also a new feature that automatically configures the relays (see section 3.2.3.3.2 “**4.2.2.2 Auto.Relay.Configuration**”, Annex 2 or I-Link Manual)

Optionally the Alarm Zones can be configured from the Control Panel, (see section, 3.2.3.3.3 “**4.2.3 Configure Alarm Zones**” Annex 2 or I-Link Manual).

Once the previous steps are complete we must verify that the programming performed is correct. For this we must monitor all the elements in all the loops of the control panel. This will be done from the control panel keys, (see section 3.2.2.4 “**Monitor**” Annex 2 or I-Link Manual).

During the startup process, the control panel may display various types of faults. For the *Onix/Quartz control panel* to work correctly, these faults must be resolved. For this, consult section 4.4 which describes the main faults, the causes of them and the action to be taken to resolve them.

4.4- Faults

4.4.1.- FAULTS IN CONTROL PANEL STARTUP

THE CONTROL PANEL DOES NOT TURN ON (POWER SUPPLY AND BATTERY leds off, display shows nothing)

Cause	Neither the 110-230V supply nor the batteries are providing the correct voltage to the panel.
Solution	Check that there is 110-230 V mains voltage in the terminal strip for connecting the AC source. Connect fully charged 24 V batteries (between 24 V and 28V).

4.4.2.- POWER SUPPLY FAULTS

LOW VOLTAGE NETWORK

Cause	The output voltage of the power supply is below than declared range.
Solution	Check that there is at least 110 VAC at mains voltage in the terminal strip for connecting the A.C. source. Check that the output voltage of the power supply is above 26VDC in the terminal strip of the circuit CDC0601FA. (See chapters 2.2.1 and 2.2.3)

HIGH VOLTAGE NETWORK

Cause	The output voltage of the power supply is above than declared range.
Solution	Check that there is no more than 230 VAC at mains voltage in the terminal strip for connecting the A.C. source. Check that the output voltage of the power supply is below 31VDC in the terminal strip of the circuit CDC0601FA. (See chapters 2.2.1 and 2.2.3)

NO BATTERY (The battery is not connected to the control panel)

Cause	Either the battery is not connected to the control panel or it is connected incorrectly.
Solution	Check that the batteries are correctly connected to the control panel, and check the status of the battery output fuse (5 Amps). Carefully examine the battery polarity and check that they are connected in series. For normal operation, the voltage in the battery output, when they are connected, should be between 22 V and 28 V. (See chapter 2.3.1)

BATTERIES FAULT / OVERLOADED (The batteries do not accept a charge)

Cause	The batteries have reached the end of their useful life.
Solution	Replace the set of batteries with new ones. For normal operation, the voltage in the battery output, when they are connected, should be between 22 V and 28 V. (See chapter 2.3.1)

BATTERIES DISCHARGED (The batteries are not charged)

Cause	The batteries are not charged, or they are not connected correctly.
Solution	Check that the two 12 V batteries are connected in series, and wait for about 12 hours for them to finish charging. If the fault persists, replace the batteries with new ones. For normal operation, the voltage in the battery output, when they are connected, should be between 22 V and 28 V. (See chapter 2.3.1)

CHARGER FAULT (The battery charger doesn't work)

Cause	The battery charger does not charge the batteries. There may be a problem with the power supply board.
--------------	--

Solution	Check the batteries connections and status as indicated above. If this fault is indicated, but there is no other associated message, checks the battery charger fuse (4 Amp). (See chapters 2.2.1, 2.2.3 and 2.3.1)
-----------------	---

30V FAULT (There is no 30V voltage at the 30V output from the Power Source)	
Cause	The fuse for this output has blown due to a short circuit or excessive power consumption.
Solution	Check the connections for the 30V output and check how many elements, such as repeaters, electromagnets, etc. are connected to it, in order to ensure that the maximum permissible power consumption is not exceeded. (See chapters 1.5.4.1 and 2.2.3)

RELAY OPEN CIRCUIT:01 (Open circuit for the S1 General Sounder relay)	
Cause	There is a lack of continuity between the output of the S1 General Sounder relay and the end-of-line resistance.
Solution	Check that S1 General Sounder output is correctly connected to the sounders connected to it, check that the end-of-line resistance (4K7) and check the supervision diodes are correctly mounted (see chapters 2.3.3.1 and 2.3.3.2). Check the status of the S1 output fuse (2 Amps). To operate correctly, the S1 General Sounder's output voltage must be between -10V and -18V when in standby and between 24V and 29V when activated.

RELAY SHORT-CIRCUITED:01 (Short circuit for the S1 General Sounder relay)	
Cause	There is a short circuit between the output of the S1 General Sounder relay and the end-of-line resistance.
Solution	Check that S1 General Sounder output is correctly connected to the sounders connected to it, check that the end-of-line resistance (4K7) and check the supervision diodes are correctly mounted (see chapters 2.3.3.1 and 2.3.3.2). To operate correctly, the S1 General Sounder's output voltage must be between -10V and -18V when in standby and between 24V and 29V when activated.

4.3.- LOOP FAULTS

ELEMENT NOT RESPONDING	
Cause	An element in the loop has stopped working.
Solution	Check that the element has not been removed from the installation, check that the element is correctly connected and that the loop voltage reaching it is between 22V and 35V. Also check that it has not been affected by external agents such as water leaks, etc. If this fault affects several elements, check whether they are all between the same two insulators. If this is the case, check that section of the installation, as there must be a short circuit in the wiring.

EXCESSIVE POWER CONSUMPTION	
Cause	The loop is overloaded or has a short circuit; the voltage in the loop is below 22V.
Solution	Check the wiring for the affected loop, check for possible short circuits, and check whether there are elements connected to the loop that should not be directly connected to it, such as: conventional detectors, end-of-line condensers or resistances, electromagnets, sounders, etc. Also check that it has not been affected by external agents such as water leaks, etc. Once the original cause of the fault has been located and resolved, wait 5 minutes before resetting the incident in the control panel, since the protection elements need to cool down. For normal operation, the voltage in the loop should be between 22V and 35V.

OPEN LOOP	
Cause	The loop is not closed correctly.
Solution	Review the wiring and the connection of the affected loop.

OPEN CIRCUIT IN MASTER (Open Circuit in the KMAY / KMAY32 master for conventional detectors)	
Cause	There is a lack of continuity in the wires for the line of slaves from the KMAY / KMAY32 to the end of the line. The end-of-line is not mounted.
Solution	Check that the KMAY / KMAY32 is correctly connected to the detectors and manual call points which are connected to it. Check that the end-of-line 10uF-63V condenser is correctly connected, and with the right polarity (see chapter 1.5.3.1). To operate correctly the KMAY's output voltage should be between 18V and 21V.

SHORT CIRCUIT IN MASTER (Short Circuit in the KMAY / KMAY32 master for conventional detectors)	
Cause	There is a short circuit in the connections from the KMAY / KMAY32 to the end of the line.
Solution	Check that the KMAY / KMAY32 is correctly connected to the detectors and manual call points which are connected to it. Check that the end-of-line 10uF-63V condenser is correctly connected, and with the right polarity, and check that the slave manual call points are connected with the correct polarity (see chapter 1.5.3.1). To operate correctly the KMAY's output voltage should be between 18V and 21V.

RELAY OPEN CIRCUIT 01 (Open circuit for the relay 1 of the MDA1Y, MDA2Y or MYOA/F)	
Cause	There is a lack of continuity between the output of the relay 1 of the MDA1Y, MDA2Y or MYOA and the end-of-line resistance.
Solution	Check that the MDA1Y, MDA2Y or MYOA/F is correctly connected to the sounders connected to it, check that the 33 KΩ end-of-line resistance and the supervision diodes are correctly mounted (see chapters 1.5.3.3, 1.5.3.4 and 1.5.3.5). Check the status of the fuse protecting the module. To operate correctly, the output voltage of the relay 1 of the MDA1Y, MDA2Y or MYOA/F must be between -2 V and -7,8 V when in standby and between 24 V and 29 V when activated.

RELAY SHORT CIRCUIT 01 (Short circuit for the relay 1 of MDA1Y, MDA2Y or MYOA/F)	
Cause	There is a short circuit between the output of the relay 1 of the MDA1Y, MDA2Y or MYOA/F and the end-of-line resistance.
Solution	Check that the MDA1Y or MDA2Y is correctly connected to the sounders connected to it, check that the 33 KΩ end-of-line resistance and the supervision diodes are correctly mounted (see chapters 1.5.3.3, 1.5.3.4 and 1.5.3.5). To operate correctly, the output voltage of the relay 1 of the MDA1Y, MDA2Y or MYOA/F should be between -2 V and -7,8 V in standby and 24 V to 29 V when activated.

RELAY OPEN CIRCUIT 02 (Open circuit for the relay 2 of the MDA2Y)	
Cause	There is a lack of continuity between the output of the relay 1 of the MDA2Y and the end-of-line resistance.
Solution	Check that the MDA2Y is correctly connected to the sounders connected to it, check that the 33 KΩ end-of-line resistance and the supervision diodes are correctly mounted (see chapter 1.5.3.5). Check the status of the fuse protecting the module. To operate correctly, the output voltage of the relay 2 of the MDA2Y must be between -2 V and -7,8 V when in standby and between 24 V and 29 V when activated.

RELAY SHORT CIRCUIT 02 (Short circuit for the relay 2 of the MDA2Y)	
Cause	There is a short circuit between the output of the relay 2 of the MDA2Y and the end-of-line resistance.
Solution	Check that the MDA2Y is correctly connected to the sounders connected to it, check that the 33 KΩ end-of-line resistance and the supervision diodes are correctly mounted (see chapter 1.5.3.5). To operate correctly, the output voltage of the relay 2 of the MDA2Y must be between -2 V and -7,8 V when in standby and between 24 V and 29 V when activated.

24V RELAY (24 V Fault in module MDA1Y, MDA2Y or MYOA/F)	
Cause	The 24 V voltages do not reach the module from the power supply's 30 V output, which may be from the control panel or from an auxiliary external power source.
Solution	Check the connections for the 30V line from the control panel's power source, or auxiliary external power source, to the 24 V input to the MDA1Y, MDA2Y or MYOA/F module, (see chapters 1.5.3.3, 1.5.3.4 and 1.5.3.5). To operate correctly, the 24 V voltage input to the modules should be between 20 V and 29 V.

OPEN CIRCUIT 01 (Open line in MSTAY / MSTAY8 input)	
Cause	There is a lack of continuity between the entrance 1 of the MSTAY / MSTAY8 and the end of line resistance.
Solution	Verify the correct connection between the MSTAY / MSTAY8 and the elements connected to it, verify the end of line resistance, 33 K Ω (see 1.5.3.2 chapter). The tension of entrance 1 of the MSTAY / MSTAY8 for a correct operation must be included between -5 V and -7 V in rest.

SHORT CIRCUIT 01 (Short line in MSTAY / MSTAY8 inputs)	
Cause	There is a short circuit between the entrance 1 of MSTAY / MSTAY8 and the end of line resistance.
Solution	Verify the correct connection between the MSTAY / MSTAY8 and the elements connected to it, verify the end of line resistance, 33 K Ω (see 1.5.3.2 chapter). The tension of entrance 1 of the MSTAY / MSTAY8 for a correct operation must be included between -5 V and -7 V in rest.

OPEN CIRCUIT 02 (Open line in MSTAY / MSTAY8 or MYOA/F input 2)	
Cause	There is a lack of continuity between the entrance 2 of the MSTAY / MSTAY8 or MYOA/F and the end of line resistance.
Solution	Verify the correct connection between the MSTAY / MSTAY8, MYOA/F and the elements connected to them, verify the end of line resistance, 33 K Ω (see 1.5.3.2 and 1.5.3.3 chapters). The tension of entrance 2 of the MSTAY / MSTAY8 for a correct operation must be included between -5V and -7 V in rest.

SHORT CIRCUIT 02 (Short line in MSTAY / 8 or MYOA/F input 2)	
Cause	There is a short circuit between the entrance 2 of the MSTAY / MSTAY8 or MYOA/F and the end of line resistance.
Solution	Verify the correct connection between the MSTAY / MSTAY8, MYOA/F and the elements connected to them, verify the end of line resistance, 33 K Ω (see 1.5.3.2 and 1.5.3.3 chapters). The tension of entrance 2 of the MSTAY / MSTAY8 for a correct operation must be included between -5V and -7 V in rest.

TECHNICAL FAULT (IN2 input to the MSTAY / MSTAY8 has been activated)	
Cause	A signal which is external to the digital detection system has activated the MSTAY / MSTAY8 IN2 input.
Solution	This is not a fault in the digital detection system; in fact this is how it should normally work. Check the operating status of the devices connected to the MSTAY / MSTAY8 (IN2).

DIRTY SENSOR	
Cause	The permitted level of dirt has been exceeded on the sensor (A30XHA, A30XHA-S, A30XHTCO, A50S/I, A50SH/I, A50HSCOI, A50SH/I/ID/IL/ILD), 100% in the monitoring screen, the sensor must be cleaned.
Solution	Clean the sensor using compressed air reset the fault and monitors the element, checking that the readings are below 5. If the levels are higher or the dirty sensor fault is repeated, cleaning it has not been sufficient and it is recommended that the sensor is replaced with a new one.

4.4.4.- OTHER FAULTS

ELEMENT NOT FOUND (In the monitoring screen)	
Cause	The loop point indicated cannot be found by the control panel.
Solution	The element being monitored either has not been installed or else its programming number has not been assigned. Check the element's configuration.

REPEATER: XX IS NOT COMMUNICATING	
Cause	There is a failure in communication with the indicated repeater.
Solution	Check the repeater's connection to the control panel, check for short circuits and broken wires, measure the repeater's supply voltage to check that it is between 24V and 30V. Check that the repeater's number is correctly configured, making sure that the number configured in the control panel is the same as the repeater's number. (see chapter 3.2.3.9)

CONTROL PANEL: XX IS NOT COMMUNICATING	
Cause	There is a failure communication with the indicated control panel.
Solution	Check the connection of the control panel with the main control panel; check short circuits, cut cables, check the correct operation of the control panel (see 1.5.5 chapter). Check that do not exist two or more control panels with the same number.

REMOTE/FAC: IS NOT COMMUNICATING / FAULT 00	
Causa	There is a failure communication with the indicated. (remote and F.A.C. are optional)
Solución	Check the connection of the control panel with the main control panel; check short circuits, cut cables, check the correct operation of the control panel. Check the settings in communication menu 4.8.(see chapter 3.2.3.9)



ATENCIÓN A LA CONEXIÓN CORRECTA DE LOS CONECTORES DEL CABLE ENTRE EL CIRCUITO DE LA CPU Y EL DE SALIDAS, YA QUE, SE PUEDEN PRODUCIR AVERIAS EN LA CENTRAL.

CARE MUST BE TAKEN WITH THE CIRCUIT CONNECTORS OF THE CPU, BECAUSE IT MAY CAUSE A FAULT SYSTEM.

S'ASSURER DE LA CONNEXION DES CONNECTEURS DU CÂBLE ENTRE LE CIRCUIT DE LA CPU ET CELUI DES SORTIES. EN CAS CONTRAIRE, DES PANNES POURRAIENT SE PRODUIRE DANS LA CENTRALE

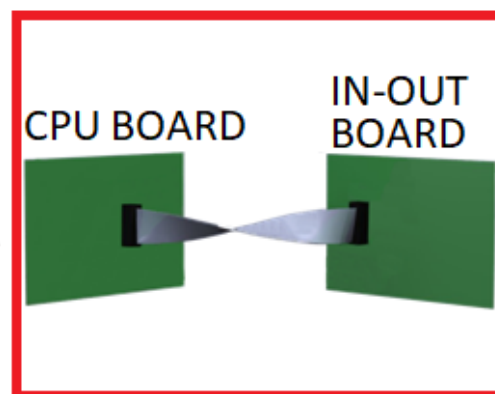

El cable debe quedar torsionado 180°

The wire is twisted 180°

Le câble doit être tordu à 180°

Figure 29. Conexión conector CPU / CPU connector connexion / CPU Connexion connecteur

NOTE:

COFEM S.A. reserves the right to make changes due to typographical errors, inaccuracies in the current information or program and/or equipment improvements at any time and without prior notice

Annex 1: Use of the Control Panel RUBI / QUARTZ / ONIX System

1. What is a control panel RUBI / QUARTZ / ONIX?

The RUBI / QUARTZ / ONIX system is a FIRE detection system that combined with detectors and corresponding modules, is capable of quickly detecting the early signs of a fire, issuing a warning of the event and acting on various elements, such as emergency exit doors, acoustic fire alarms or crossed outputs.

2. Front panel of the system

This is how the control panel of the systems looks like:

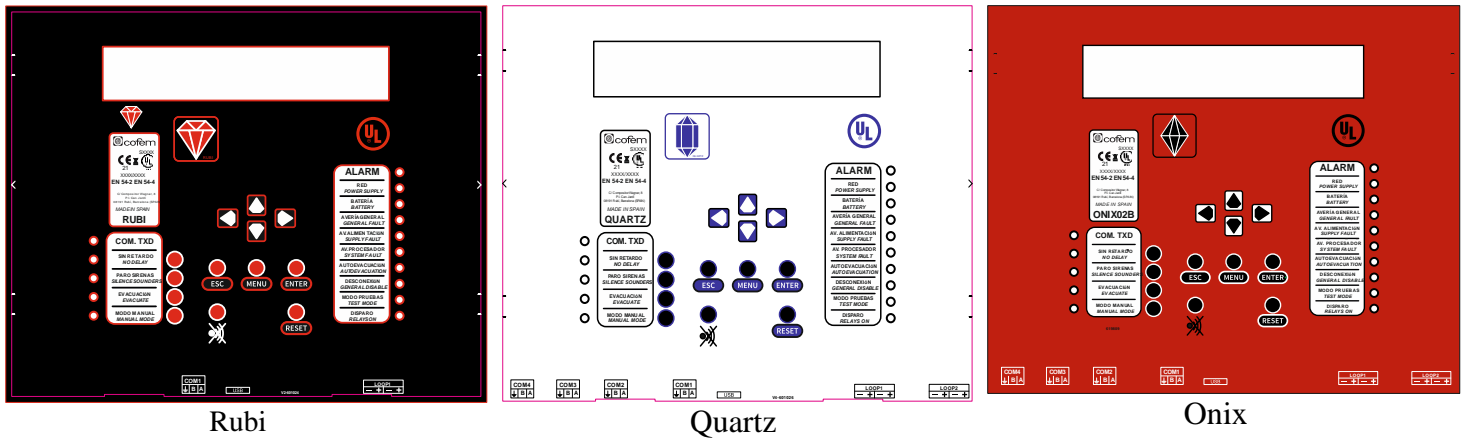

The **keys** enable action to be taken via the control unit, while the **luminous indicators (LEDs)** and the **screen** provide information about the system status.

3. What happens if the buzzer sounds?

The buzzer or acoustic warning emits an intermittent alarm if any of the following situations arise:

1. A **fire alarm** has been generated.
2. A relay has been **actuated**.
3. A **fault** has occurred in the detection system.

To stop the buzzer, press this key:



IMPORTANT: THE INCIDENT must always be CHECKED when this key is pressed.

4. Checking the incident

Having stopped the buzzer, the user must check the incident. For this purpose, the control unit incorporates a screen to display information and various luminous indicators that provide details regarding the incident that has occurred. The options are: an **ALARM**, an **ACTUATION** or a **FAULT**.

In the event of several types of incident occurring simultaneously, the display can be toggled by pressing the **ENTER** key. The information displayed on the screen can be expanded using:

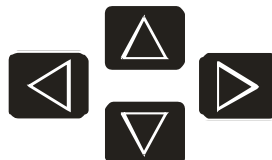

If the incident in question is an **ALARM**, the user must verify whether it is real. If so, the order to evacuate can be given. Beforehand, **the keypad must be enabled** and also if any of the keys on the control panel are pressed, except for the **buzzer** (the control panel requests a code to be entered):

To enable the keypad, the access code must be entered by using the (▲▼◀▶) keys:

The access code is:
27
(This must be confirmed with the ENTER key).

This operation must be performed each time an access code is requested. Once the code has been entered, all the keys on the control panel can be used.

5. Evacuation

This function can be performed once the **keypad has been enabled** and by pressing the evacuation key.



IMPORTANT: This must be confirmed with the **ENTER** key

This function activates all **sirens** and **switches** in the system. This is also shown by lighting the luminous indicator.

6. SILENCE SIRENS

When required, this function enables the sirens to be silenced. The **keypad** must be **enabled** and it is performed by pressing the SILENCE SOUNDERS key:



IMPORTANT: while the luminous indicator is lit, the system's sirens will **NEVER** be activated.

7. RESET EVENTS

In the case of a false alarm, the user must **Reset** the alarm. With the **keypad enabled**, select the alarm to be reset and press the **reset** key:



IMPORTANT: when an alarm is reset, this must be confirmed with the **ENTER** key

If the incident is a **FAULT**, this must also be **Reset** following the exact same process as explained above. If the **FAULT** reoccurs, contact the technical service.

DISCONNECT the 110-230Vac voltage circuit before accessing the interior of the control panel , and then disconnect the batteries.

Annex 2: Elements configuration RUBI / QUARTZ / ONIX

1. Introduction

The steps necessary to configure the Addressable Control Panel are given below.

The addressable system includes the following elements:

Addressable sensors

Optical sensor	A30XHAS	A50S	/ I
Heat sensor	A30XTA	A50H	/ I
Optical and Heat sensor	A30XHA	A50SH	/ I
Multi-sensor	A30XHTCO	A50HSCOI	

Addressable key

PUCAY

Master module

KMAY

Relay modules

1 relay	MDA1Y
2 relay	MDA2Y

Technical signals module

MSTAY / MSTAY8

Relay and Technical signal module

MYOA / F

Loop isolator base

KABY

Addressable siren

SIRAY / SIRAYL / SIRAY+BSLC

Addressable Sound/Light, Sound&Light Smoke/heat smoke&heat detectors

A50SI/L/D/LD
A50HI/L/D/LD
A50SHI/L/D/LD

Each of these elements has a programming label. This number is assigned at the factory.

When an element search operation is conducted using the control unit, it finds all the loop elements, storing the type of element and the assigned programming number.

The basic purpose of this procedure is that, by conducting this search, all these numbers can be passed to the control unit memory and for them to be assigned to the loop where the search was conducted.

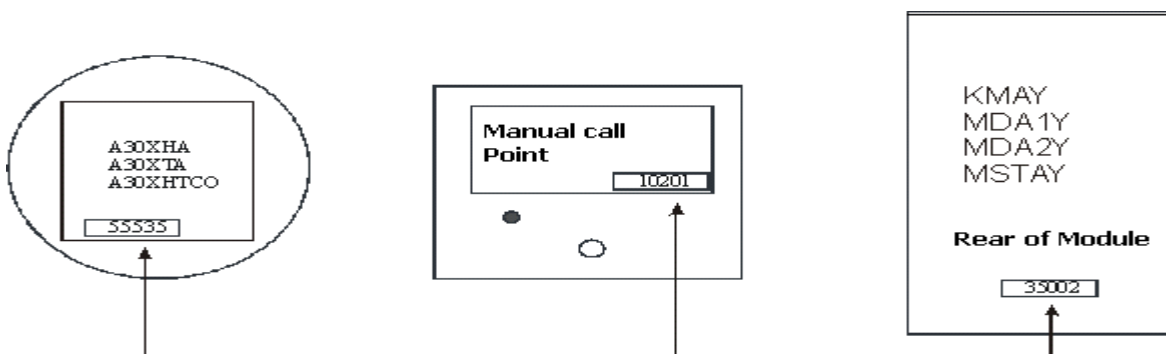

NOTE: Before assigning a point, it is highly advisable to obtain the programming lists with all the data.

2. Keypad access

If the keypad has not been enabled, the only key that will work is the stop **BUZZER** button (*in the event of any new incidents, the buzzer will be activated again*).

The system provides several different access levels to the various internal functions. The first level of access controls the use of the keypad.

When any of the keys on the control panel are pressed, an access code will be requested:

AN ACCESS CODE WILL BE REQUESTED N° 27

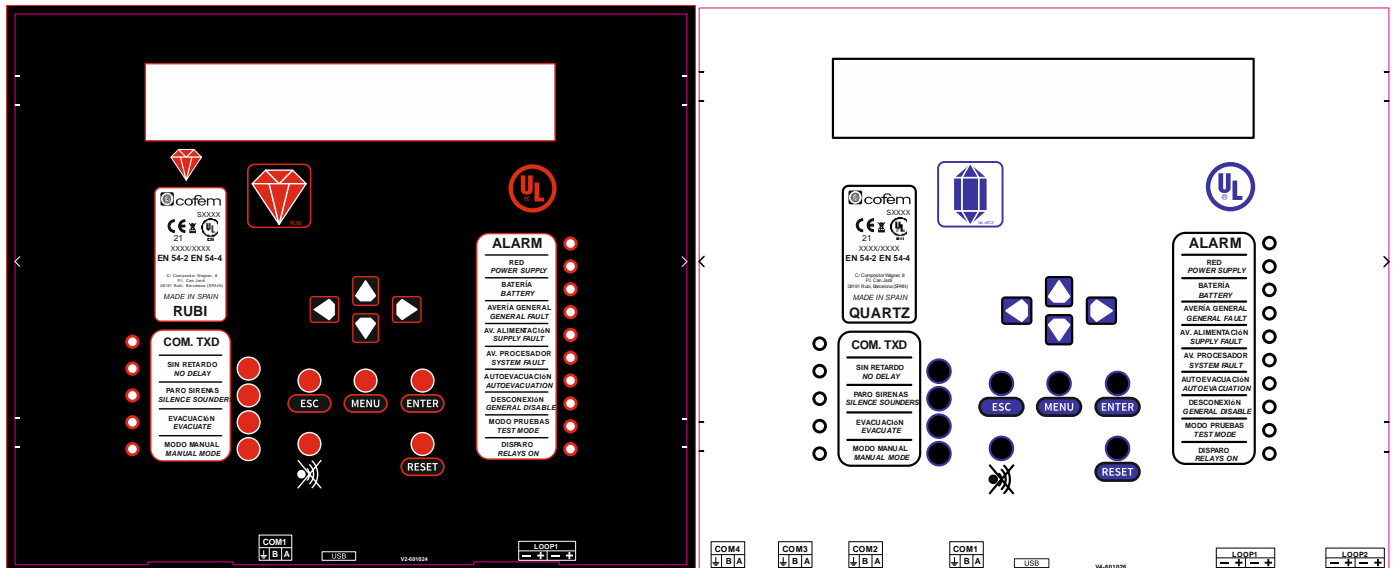
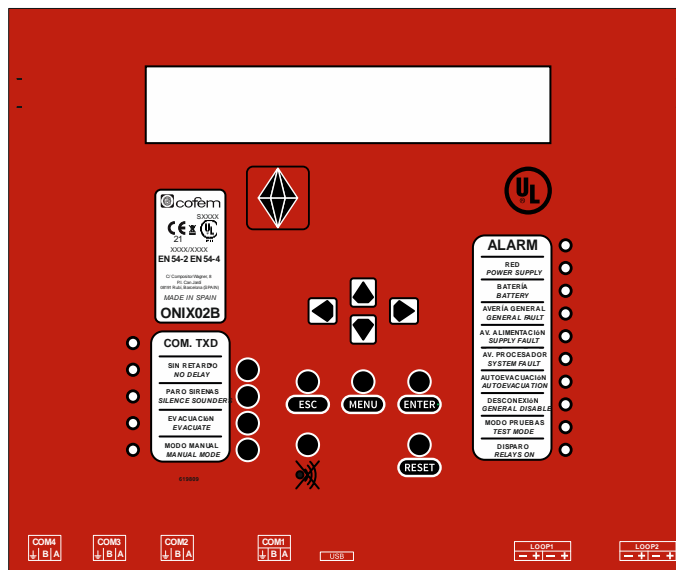

IMPORTANT: If no key is pressed within a period of 30 seconds, the keypad is blocked and the previous step must be repeated in order to continue using the keypad.

As soon as keypad access has been provided, all keys can be used immediately.

3. Configuration of points in a loop

Pressing the menu button will show the main menu on the display.

KEYS FOR NAVIGATING
THE MENUS

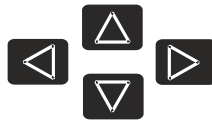

ESCAPE KEY
(Return to previous screen)



ENTER KEY
(Confirm menu options)

By using the arrow keys, the menu options below will be displayed:

Main
1. Monitoring
2. Logic relay activation
3. General relays
4. System Setup
5. Enable/disable points/zones
6. System Test
7. Welcome message
8. General Rearm
9. Review history

3.1. System Programming

By selecting option **4 System Configuration**, the access code for level 3 will be requested. Enter the code and confirm with the **ENTER** key. **AN ACCESS CODE WILL BE REQUESTED N° 9000**

The following menu will appear on the display:

4. System Setup
4.1. Label points
4.2. Configure
4.3. Set up time and date
4.4. Day/night timetable
4.5. Swap test/normal
4.6. Led ON/OFF
4.7. Language menu
4.8. Communications
4.9. Sounder stop function

3.2. Configure

Select option **3 Configure**, and confirm with the **ENTER** key.

The following menu with 9 options will appear on the display:

4.2. Configure
4.2.1. Loop configuration
4.2.2. Logic In/out configuration
4.2.3. Configure alarm zones
4.2.4. Set up point sensitivity
4.2.5. Additional Passwords
4.2.6. Autoevacuation Setup
4.2.7. Added Delay Setup
4.2.8. Fast trigger Zone
4.2.9. To Send Zones to Repeaters

3.3-Configure Loop

By selecting option **1 Loop Configuration** the option will be the first to appear. Confirm with the **ENTER** key. You will be asked for the number of the loop to be configured.

The following menu with 3 options will appear on the display:

4.2.1. Loop configuration
4.2.1.1. Sensibility of a type
4.2.1.2. Blink
4.2.1.3. Set up Loop Points

3.4.-Loop Configuration

The first step is to configure the elements of the loop so that the control unit recognizes all the Elements that are connected to each of the loops.

By selecting option **3 Set up loop Points** the option will be the first to appear. Confirm with the **ENTER** key.

The following menu with 7 options will appear on the display:

4.2.1.3. Set up Loop Points
4.2.1.3.1. View loop information
4.2.1.3.2. Loop points Search
4.2.1.3.3. Assign Point number
4.2.1.3.4. Loop Automatic Configuration
4.2.1.3.5. Delete Point
4.2.1.3.6. Change point
4.2.1.3.7. Delete Loop Points

By selecting option **2 Loop points Search** the option will be the first to appear. Confirm with the **ENTER** key.

Confirm with ENTER (Menu(code 27) →4.-System setup→2.-Configure→1.-Loop configuration→3.-Set Up Loop Points→2.-Loop points Search)

4.2.1.3.2. Loop points Search
4.2.1.3.3. Assign Point number
4.2.1.3.4. Loop Automatic Configuration
4.2.1.3.5. Delete Point
4.2.1.3.6. Change point
4.2.1.3.7. Delete Loop Points

This function passes all the programming numbers to the control unit memory and, after a few seconds, the total number of elements that have been configured in the loop will appear on the display and how many there are of each type.

This search will take approximately 2 minutes.
Check that the information displayed is correct.

Important note:

- **This step must be performed for each of the installed loops.**
- **It must be done even if there are no elements connected to the loop.**

3.5.-Assign a number to Point

Confirm with the **ENTER** key.(Menu(code 27) →4.-System setup (code 9000) →2.-Configure→1.Loop configuration→3.-Set up Loop Points→ 3.- Assign Point number)

This option assigns a loop and an order number within the loop to each element.

```

1. Monitoring
2. Logic relay activation
3. General relays
4. System Setup
   4.1. Label points
   4.2. Configure
       4.2.1. Loop configuration
           4.2.1.1. Sensibility of a type
           4.2.1.2. Blink
           4.2.1.3. Set up Loop Points
               4.2.1.3.1. View loop information
               4.2.1.3.2. Loop points Search
               4.2.1.3.3. Assign Point number
               4.2.1.3.4. Loop Automatic Configuration
               4.2.1.3.5. Delete Point
               4.2.1.3.6. Change point
               4.2.1.3.7. Delete Loop Points

```

Important:

In order to proceed with this operation, the installer must have made written note of the programming number of each of the sensors and the loop in which they are installed.

Firstly, you will be asked for the programming number of the corresponding Point, confirmed with the **ENTER** key. Secondly, you will be asked for the assigned Point number, confirmed with the **ENTER** key.

4.-Programming verification process

It is always recommended to check that programming has been performed correctly.

```

Main
1. Monitoring
2. Logic relay activation
3. General relays
4. System Setup
5. Enable/disable points/zones
6. System Test
7. Welcome message
8. General Rearm
9. Review history

```

• **Monitor**

This function is number 1 on the first menu. Select with the ENTER key.
The control panel will ask first for the loop number and then the point number.

Loop	001	Point	003					A30XHA				
Loop :	001	Punto :	001					S.Numb. :	29184			
Temp. :		[024	024	024	025]			Values :	- - -			
Dir t		- - -	Average :	024				Sensitiv :	HIG			

Check that the information shown is correct.

With the (← →) arrow keys, it is possible to change from one point to another.

With the (↑ ↓) arrow keys, it is possible to change from one loop to another

- 3- Delete the point removed from the loop. **“Set up Loop Points” → option 5**
- 4- Insert the new element (having previously made note of the point number).
- 5- Search loop element. **“Set up Loop Points” → option 2.**
When this has been completed, the configuration will be shown on the display.
Check that the configuration is the same as in step 2 above, but with the new element added.
- 6- Assign number to element. **“Set up Loop Points” → option 3**
- 7- Whenever a modification is made, the changes should always be checked. **Main menu → option 1.**

Main

1. Monitoring

2. Logic relay activation

3. General relays

4. System Setup

4.1. Label points

4.2. Configure

4.2.1. Loop configuration

4.2.1.1. Sensibility of a type

4.2.1.2. Blink

4.2.1.3. Set up Loop Points

4.2.1.3.1. View loop information

4.2.1.3.2. Loop points Search

4.2.1.3.3. Assign Point number

4.2.1.3.4. Loop Automatic Configuration

4.2.1.3.5. Delete Point

4.2.1.3.6. Change point

4.2.1.3.7. Delete Loop Points



Caution
Risk of electric shock

DISCONNECT the 110-230Vac voltage circuit before accessing the interior of the control panel , and then disconnect the batteries.



Caution
Risk of electric shock

WARNING! Live voltage inside (110-230V)!
Unplug the unit when manipulating live wires or main fuse!

NOTE:

COFEM S.A. reserves the right to make changes due to typographical errors, inaccuracies in the current information or program and/or equipment improvements at any time and without prior notice.

