

Features

- Designed to not interfere with the operation of the protected unit.
- Fast and easy installation.
- Simple removal for servicing the units.
- Constructed from 9 gauge galvanised steel rod.
- Plastic coated for durability and use in harsh environments.
- Protects against vandalism or accidental damage

Application

This steel cage is designed to protect OSID Imagers and Emitters from vandalism and accidental damage.

The cage is constructed of heavy gauge steel wire with corrosion resistant polyester coating.

Installation and servicing are easy.

Highly recommended for areas where abuse to beams is severe.

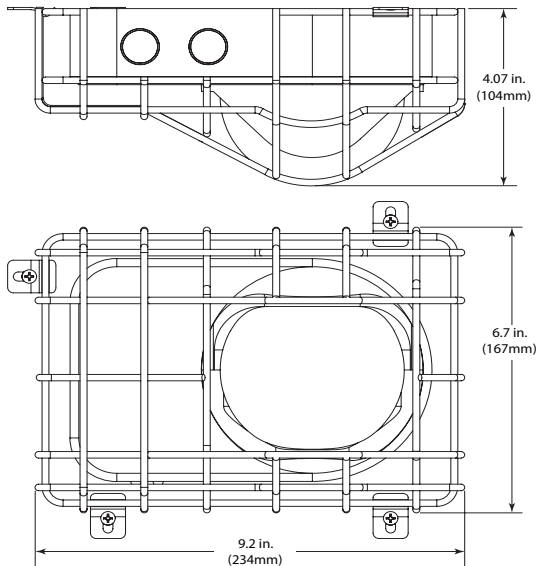

Specifications

Material:

Hard drawn steel wire

Thickness:

9 gauge - 0.144" (0.366mm) Diameter

Finish:

Polyester Powder Coating -
Non Carcinogenic

Colour:

White

HMS:

Code-010E

Ordering Codes

OSID-WG Wire Guard for Imager and Emitter

www.xtralis.com

The Americas +1 781 740 2223 **Asia** +852 2916 8876 **Australia and New Zealand** +61 3 9936 7000
UK and Europe +44 1442 242 330 **Middle East** +962 6 588 5622

The contents of this document are provided on an "as is" basis. No representation or warranty (either express or implied) is made as to the completeness, accuracy or reliability of the contents of this document. The manufacturer reserves the right to change designs or specifications without obligation and without further notice. Except as otherwise provided, all warranties, express or implied, including without limitation any implied warranties of merchantability and fitness for a particular purpose are expressly excluded.

This document includes registered and unregistered trademarks. All trademarks displayed are the trademarks of their respective owners. Your use of this document does not constitute or create a licence or any other right to use the name and/or trademark and/or label.

This document is subject to copyright owned by Xtralis AG ("Xtralis"). You agree not to copy, communicate to the public, adapt, distribute, transfer, sell, modify or publish any contents of this document without the express prior written consent of Xtralis.

Doc. No. 21595_00

Part No. 29988