

Safety Information

Electrical equipment should be installed, operated, serviced, and maintained only by qualified personnel. No responsibility is assumed by Schneider Electric for any consequences arising out of the use of this material.

Esmi Impresia IP67 Manual Call Point

The addressable manual call point Esmi Impresia IP67 Manual Call Point (FFS06741005) is designed for outdoor installations and IP67 environments*. The call point has a built-in isolator. The call point is also equipped with a protective transparent cover for avoiding of fault or accidental activation. Esmi Impresia IP67 Manual Call Point is designed for installing in addressable fire alarm systems with Esmi ELC loop controller supporting Schneider Electric communication protocol.

The address setting is done by the panel, QR code or handheld addressing device. The address range is 1-250.

* The declared IP67 is achieved only when using IP67 rated cable glands!

Testing

Before testing make sure all persons in the building are aware of the test! If needed disconnect fire alarm devices, alarm transmitters and other fire outputs before the test. Use the special tool to test the call point operation function ability - insert the tool in the "Test" hole and push up to test. The tool moves the flexible element up and thus operates the call point. The LED will light up while the call point is in test mode.

Technical Specifications

Operating voltage	15÷32 VDC
Current consumption without communication (max)	125µA@27VDC
Current consumption with communication (max)	160µA@27VDC
Current consumption in Fire mode	3mA
Installation wires	2.5mm ²
Relative humidity	≤93% @ +40°C
Material (plastic), color	ABS, red
Type (according EN 54-11, 17)	A
Type of the frangible element	resettable (flexible)
Indication "Fire alarm"	red LED
Supported communication protocol	Esmi ELC

Isolator Module Technical Specifications

Maximum line voltage (V_{max})	32V
Nominal line voltage (V_{nom})	28V
Minimum line voltage (V_{min})	15V
Maximum voltage at which the device isolates ($V_{so max}$)*	7.5V
Minimum voltage at which the device isolates ($V_{so min}$)*	5.9V
Maximum voltage at which the device reconnects ($V_{sc max}$ **)	6.7V
Minimum voltage at which the device reconnects ($V_{sc min}$ **)	5V
Maximum rated continuous current with the switch closed ($I_c max$)	0.7A
Maximum rated switching current (e.g. under short circuit) ($I_s max$)	1.8A
Maximum leakage current with the switch open (isolated state) ($I_l max$)	16mA
Maximum series impedance with the switch closed ($Z_c max$)	0.12Ω@28VDC and 0.15Ω@15VDC

* Note: Switches from closed to open

** Note: Switches from open to closed



Dimensions

114mm, 114mm, 80mm

Installation

IP67

-10°C ÷ +60°C

~262g

Indoor and Outdoor Use

CE 21

1293

DoP No: DP20021

Made in Bulgaria

EN 54-11:2001

EN 54-11:2001/A1:2005

EN 54-17:2005

EN 54-17:2005/AC:2007

EN 60529+A1:2004

Note: Collect the QR code stickers from the devices if QR codes are used for addressing of the devices. Follow the applicable local and national installation codes and regulations.

Electrical equipment should be installed, operated, serviced, and maintained only by qualified personnel. No responsibility is assumed by Schneider Electric for any consequences arising out of the use of this material.

1 Structure

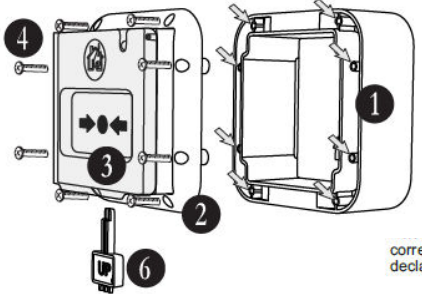

(1) - Back box for surface mounting
 (2) - Front cover
 (3) - Protective transparent cover
 (4) - Screws (8 pcs.) for fixing the front cover to the back box
 (5) - Front cover back side
 (6) - Tool for testing and resetting of the call point in stand-by mode (use the tool as shown on the picture - the "UP" mark must be in front)

The o-ring sealant must be correctly fitted in the channel to provide the declared IP67 rating!

2 Surface Mounting

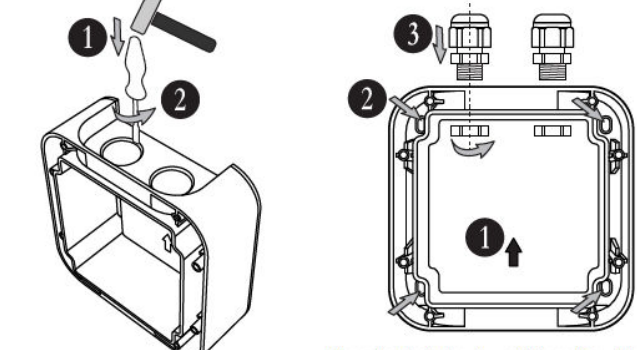

Remove the protective caps of the cable gland holes

Place the back box in upright position; Mount the back box using screws according the mounting surface; Mount cable glands with IP67 into the holes and tighten the nuts underneath.

3 Connection Diagram

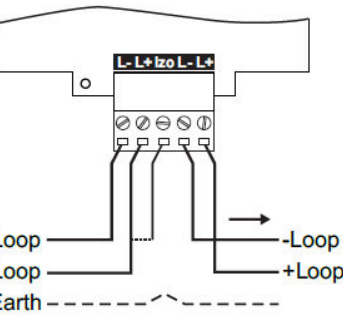

Power off the loop circuit before installing the Manual Call Point

Important: When you use the integrated short circuit isolation module connect one of the "+Loop" loop lead to the "Izo" terminal of the call point.

4 Testing the operation

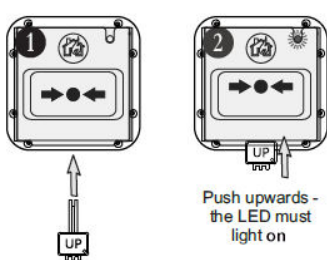

The "UP" mark must be in front.

Push upwards - the LED must light on

5 Alarm Indication

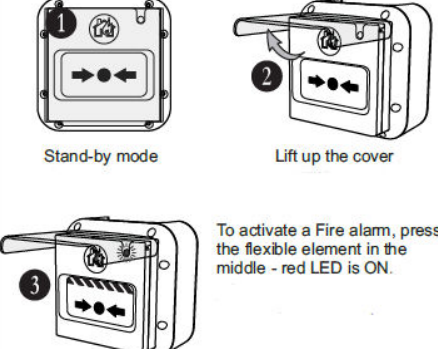

Stand-by mode

Lift up the cover

To activate a Fire alarm, press the flexible element in the middle - red LED is ON.