

# THE EXM2 SERIES OF MONITORS

## INNOVATIVE TECHNOLOGY

## INNOVATIVE SOLUTIONS



**EXM<sup>2</sup>**

- 
- Durability
  - Integration
  - Performance
  - Control
-

# THE EXM2 SOLUTION: IT ALL ADDS UP

## DURABILITY + TECHNOLOGY = THE TOTAL SOLUTION

### Robust Joint Design

Each swivel joint contains 2 sets of stainless steel ball bearings, a hardened thrust rod and thrust bearings, engineered and manufactured to withstand the shearing action of water pressure while absorbing the effects of extreme vibration that damages weaker monitors.

### Potted Electronics

The EXM2 Control Module electronics are encased in a thermo-set plastic compound that provides resistance to shock and vibration, while blocking out moisture and other corrosive agents.

### Heavy Duty Motors

Unlike the competition, EXM2 monitors utilize extreme durability/high frequency motors that provide a distinct advantage in continuous use applications such as construction, mining and deicing. EXM2 motors also carry the extra torque required for operating ARFF, deicing and other specialty nozzles.

### Teflon Impregnated Anodized Aluminum Alloy Waterway

The corrosion-resistant elliptical waterway, capable of withstanding up to 500 PSI operating pressure, reduces turbulence to provide an efficient method of water delivery. This results in reduced load on the apparatus pump.

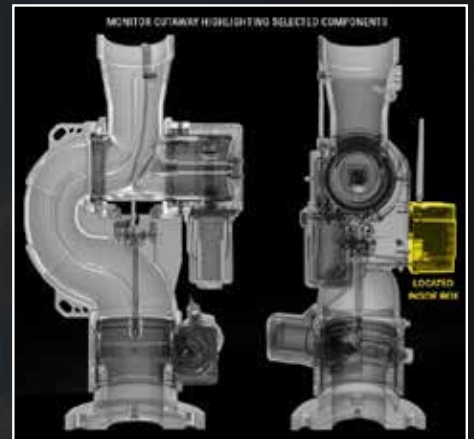
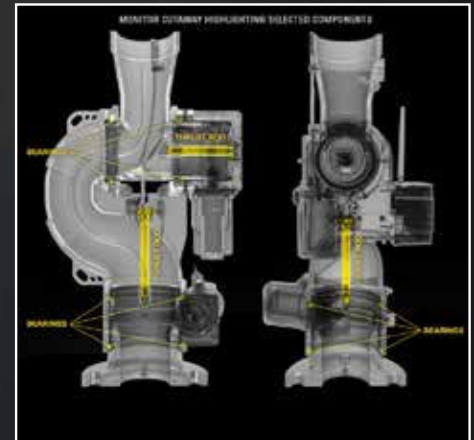

# THE EXM2 SOLUTION: LEADING EDGE TECHNOLOGY

## DURABILITY + TECHNOLOGY = THE TOTAL SOLUTION

### Wi-Fi Connectivity



The EXM2 system includes an integrated Wi-Fi server within the monitor control module. This provides secure access to the EXM2 browser page for simple, intuitive configuration of the monitor and controllers when required. Connecting to the monitor via Wi-Fi also allows you to set travel limits and keep out zones, retrieve diagnostic information, all from a Wi-Fi capable tablet or laptop.



### EXM2 Input Controllers

All EXM2 Controllers include

- Standard monitor controls for **UP/DOWN/LEFT/RIGHT**
- Dedicated **STOW, DEPLOY** and **OSCILLATE** buttons
- Nozzle controls for **FOG/STREAM**
- **OPEN, CLOSE** and **PRESET** controls for optional Unibody Valve
- **AUX** button for powering an external device such as a light or camera



### Panel Mount Controller 7010X2

Designed to be mounted on a panel, the controller is hardwired directly to the monitor via CANbus. Compatible with 12 or 24VDC systems and rated to IP67.

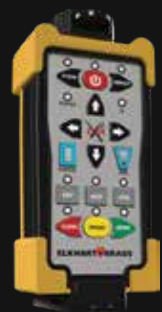

### Wireless Handheld Controller/Gateway 7015X2

The IP67 rated wireless remote control includes everything needed to operate a monitor, nozzle and optional Unibody valve from a safe location. The docking station with built-in induction charging system eliminates the need for replaceable batteries. The wireless controller comes pre-configured to communicate via RF to the Gateway Module. The module, with an external antenna, can then be mounted in a location convenient to the apparatus builder. The Gateway connects via CANbus harnesses directly to the monitor.



### Joystick Controller 7030X2

The joystick controller is designed to be surface mounted in the vehicle cab, providing convenient and intuitive control of the monitor. Containing all of the EXM2 monitor controls, the joystick utilizes proportional speed control for precise positioning of the water stream. Operate a Unibody Valve using the joystick trigger or the OPEN/CLOSE buttons on the mounting plate. Integrating CANbus within the joystick design eliminates the need for an external module, simplifying installation and programming.



### Position Display 7051X2

The Position Display provides instant feedback to the operator on the monitor's current position utilizing the signal from the monitor's integrated position sensors.



### UNIBODY VALVE WITH E14X ACTUATOR

The optional Unibody Valve, compatible with all EXM2 systems, provides on/off or gateable control of the water supply to the monitor. Control the valve with any of the EXM2 input controllers or with an APEX Electric Valve Controller.

### Programmable Travel Limits and Keep Out Zones

User definable travel limits and keep out zones, programmed and stored in the EXM2 monitor control module, allow you to set parameters that limit the movement of the monitor. These limits are used to ensure the water stream is maintained within a safe area and prevent damage to equipment and personnel.

### Programmable Deploy and Stow Positions

The DEPLOY function allows you to move the monitor to a pre-determined attack position with the press of a button, while the STOW feature returns the monitor to a programmed home position.

This is how Elkhart Brass challenges our monitors so they are the right choice for you:

**DURABILITY  
+ TECHNOLOGY  
= THE TOTAL  
SOLUTION**

---

### **Extreme Heat Test\***

- Exposed to 185°F (85°C) for 24 hours

---

### **Extreme Cold Test\***

- Exposed to -40°F (-40°C) for 24 hours

---

### **Solar Radiation Exposure\***

- 24 hour cycle of infrared heat exposure

---

### **Temperature Shock Test\***

- -40°F (-40°C) to 81°F (27°C)

---

## Blowing Rain\*

- 30 minutes blowing rain @ 60 feet (18 meters) per second

---

## Blowing Dust\*

- 12 hours exposure to blowing dust @ 30 feet (9 meters) per second

---

## Blowing Sand\*

- 6 hours exposure to blowing sand @ 59 – 95 feet (18 – 29 meters) per second

---

## Vibration and Shock Testing\*

- 3 axis vibration testing – 60 minutes per axis (40g shock impact on all 4 axes)

---

## NEMA 4 Enclosure Test\*

- Electrical Enclosures - 1.0" Diameter water stream (65 gpm/246 lpm) on all potential leak paths for duration of 5 minutes

---

## High Pressure Test to Failure\*

- Pressurized to failure – monitor held 2700 PSI for 1 minute then failed at 2800 PSI (186 bar)

---

## High Pressure Cycle Test\*

- 10,000 cycles while pressurized @ 250 PSI (17 bar)
- 4 hours cycling while pressurized @ 500 PSI (34 bar)

# SIDEWINDER® EXM2 700 GPM/2800 LPM

At 700 GPM, the Sidewinder EXM2 provides a compact, durable solution for mining, construction and wildland firefighting. Available in **Standard Duty** and **Heavy Duty models**, the Sidewinder EXM2 delivers an excellent water stream when matched with a 6000 Series electric nozzle. The 7070 Joystick, with integrated water valve control, is the preferred control option for the Sidewinder EXM2.

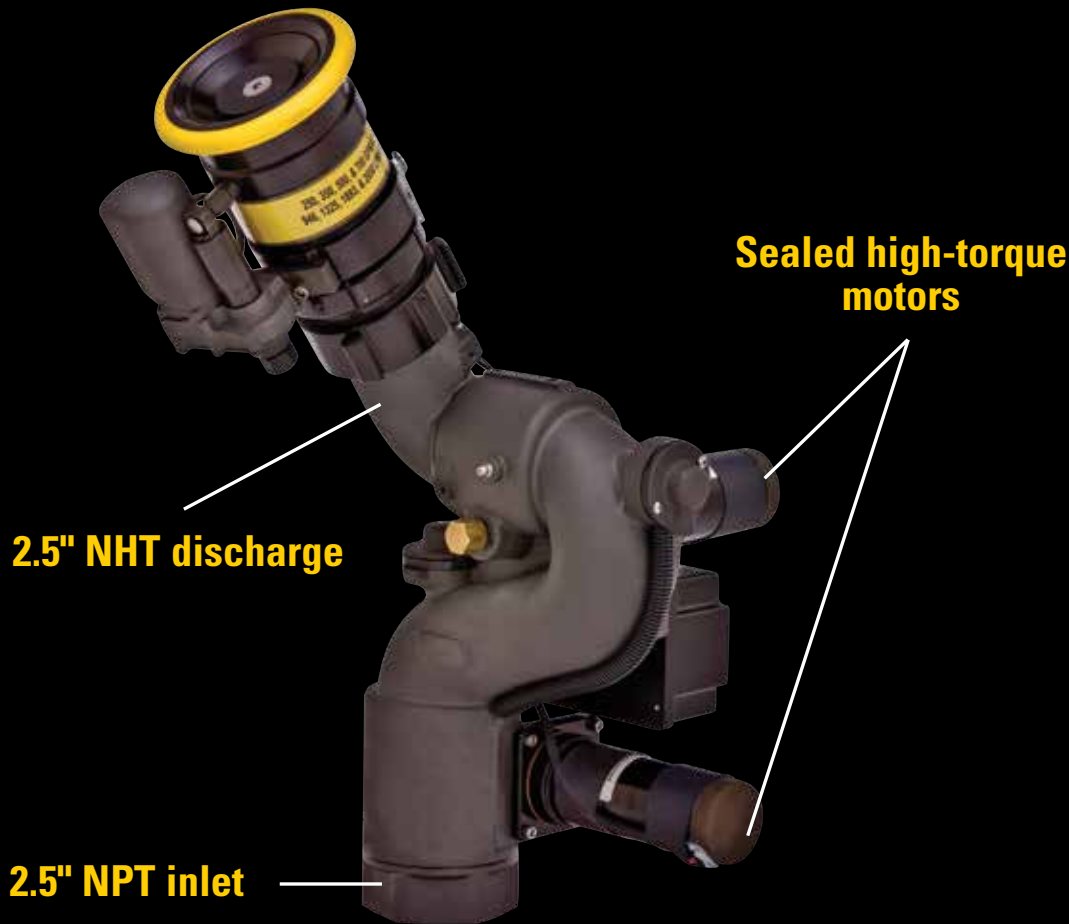

## SPECIFICATIONS

<b>Model:</b>	7100SDX2/7100HDX2
<b>Max Flow:</b>	700 GPM (2800 LPM)
<b>Max Pressure:</b>	500 PSI (34.5 bar)
<b>Inlet:</b>	2.5" NPT
<b>Outlet:</b>	2.5" NHT
<b>Travel:</b>	Vertical: -45° to +90° (135°) Horizontal: L175 to R175 (350°)
<b>Voltage:</b>	12 or 24 VDC compatible
<b>Control:</b>	CANbus J1939
<b>Communication:</b>	915 MHz RF - FCC 868 MHz RF - CE
<b>Material/Finish:</b>	Teflon impregnated, hard anodized Elk-O-Lite®
<b>Stow Height</b>	13.2" (335mm)
<b>Weight:</b>	18 lbs (8.2 kg)

## Vehicle Applications

- Brush Truck
- Quick Attack Vehicles
- ARFF



## COMPONENTS & OPTIONS

## MODEL

<b>Electric Nozzles</b>	Selectable	15/30/45/60/95/125/150/200/FLUSH GPM	6000-200E
		250/350/500/700/FLUSH GPM	6000-700E

# SIDEWINDER® EXM2 300 GPM/1200 LPM

Designed to meet U.S. Military specifications, the **Ultra High Pressure** version of the Sidewinder EXM2 offers up to 300 GPM at 1500 PSI. Available in multiple flow options, the Sidewinder EXM2 UHP is the ideal monitor for rapid attack firefighting that requires significant stream penetration along with water conservation.

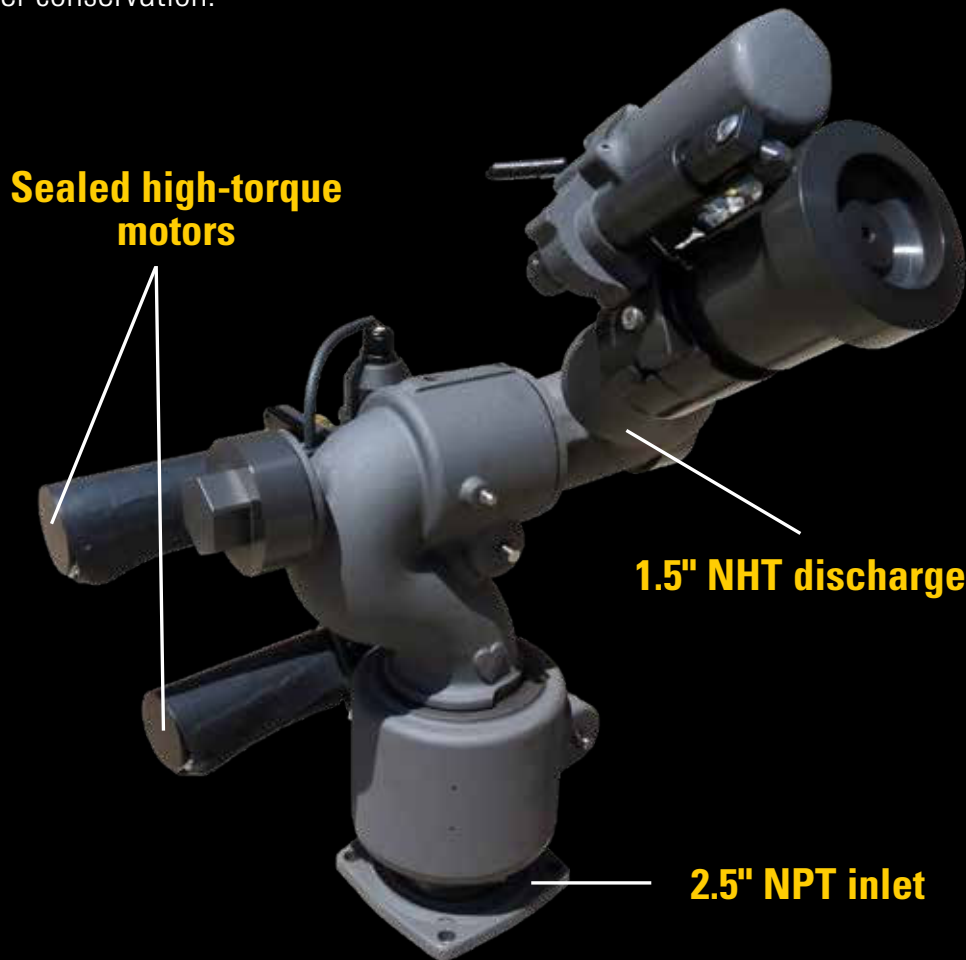

## SPECIFICATIONS

<b>Model:</b>	7161X2
<b>Max Flow:</b>	300 GPM (1200 LPM)
<b>Max Pressure:</b>	1500 PSI (103 bar)
<b>Inlet:</b>	2.5" NPT
<b>Outlet:</b>	1.5" NHT
<b>Travel:</b>	Vertical: -45° to +90° (135°) Horizontal: L90 to R90 (180°)
<b>Voltage:</b>	12 or 24 VDC compatible
<b>Control:</b>	CANbus J1939
<b>Communication:</b>	915 MHz RF - FCC 868 MHz RF - CE
<b>Material/Finish:</b>	Teflon impregnated, hard anodized Elk-O-Lite®
<b>Stow Height:</b>	12.3" (313 mm)
<b>Weight:</b>	27 lbs (12.2 kg)

## Vehicle Applications

- ARFF
- Deicing Vehicles



## COMPONENTS & OPTIONS

## MODEL

<b>Electric Nozzle</b>	Fixed	60 GPM (240 LPM) with Flush	5000-14E UHP
------------------------	-------	-----------------------------	--------------

# COBRA™ EXM2 1500 GPM/6000 LPM

Offered in either **1250 GPM or 1500 GPM** along with **Standard or Heavy Duty** versions, the Cobra EXM2 is the preferred monitor for aerial apparatus OEMs. With its 6" swing radius and 16" stow height, the Cobra EXM2 fits into small spaces on aerials and platforms. Add an SM Series nozzle and you have the perfect product for your new aerial device.

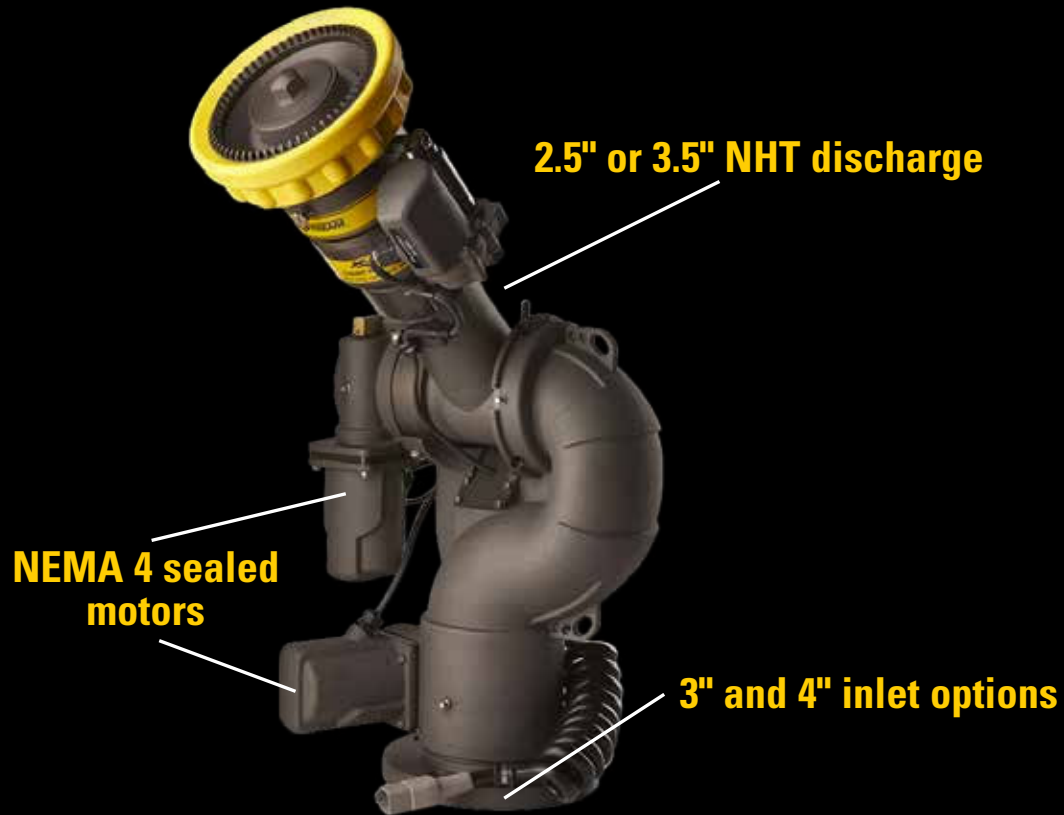

## SPECIFICATIONS

<b>Model:</b>	7200X2/7250X2
<b>Max Flow:</b>	1250 GPM (5000 LPM) 1500 GPM (6000 LPM)*
<b>Max Pressure:</b>	500 PSI (34.5 bar) Limited Duty
<b>Inlet:</b>	3" -150# Flg, 4" -150# Flg, 3" NPT, 3" BSPT, & DN80-PN16"
<b>Outlet:</b>	2.5" / 3.5" Male NHT & BSPP
<b>Travel:</b>	Vertical: -45° to +120° (165°) w/ Extended Travel Horizontal: L175 to R175 (350°)
<b>Voltage:</b>	12 or 24 VDC compatible
<b>Control:</b>	CANbus J1939
<b>Communication:</b>	915 MHz RF - FCC 868 MHz RF - CE
<b>Material/Finish:</b>	Teflon impregnated, hard anodized Elk-O-Lite®
<b>Swing Radius:</b>	6" (152mm) 180°, 8" (203mm) 360°
<b>Stow Height:</b>	16" (406mm)
<b>Weight:</b>	31 lbs (14 kg) / 32 lbs (14.5 kg)

## Vehicle Applications

- Deck Mount
- Aerials/Platforms



## COMPONENTS & OPTIONS

## MODEL

Electric Nozzles			
X-Stream Series Automatic	2.5" Inlet:	350-1000 GPM (1400-4000 LPM)	SM-1000E
	2.5" Inlet:	350-1250 GPM (1400-5000 LPM)	SM-1250E
	3.5" Inlet:	500-1500 GPM (2000-6000 LPM)	SM-1500E

# SCORPION<sup>®</sup> EXM2 2500 GPM/10,000 LPM

With its 3.5" vaned waterway, the Scorpion EXM2 provides large flow – up to **2500 GPM** – with minimal turbulence. The stainless steel thrust rods, standard on all EXM2 monitors, make the Scorpion the most durable, dependable monitor for high-volume firefighting applications.

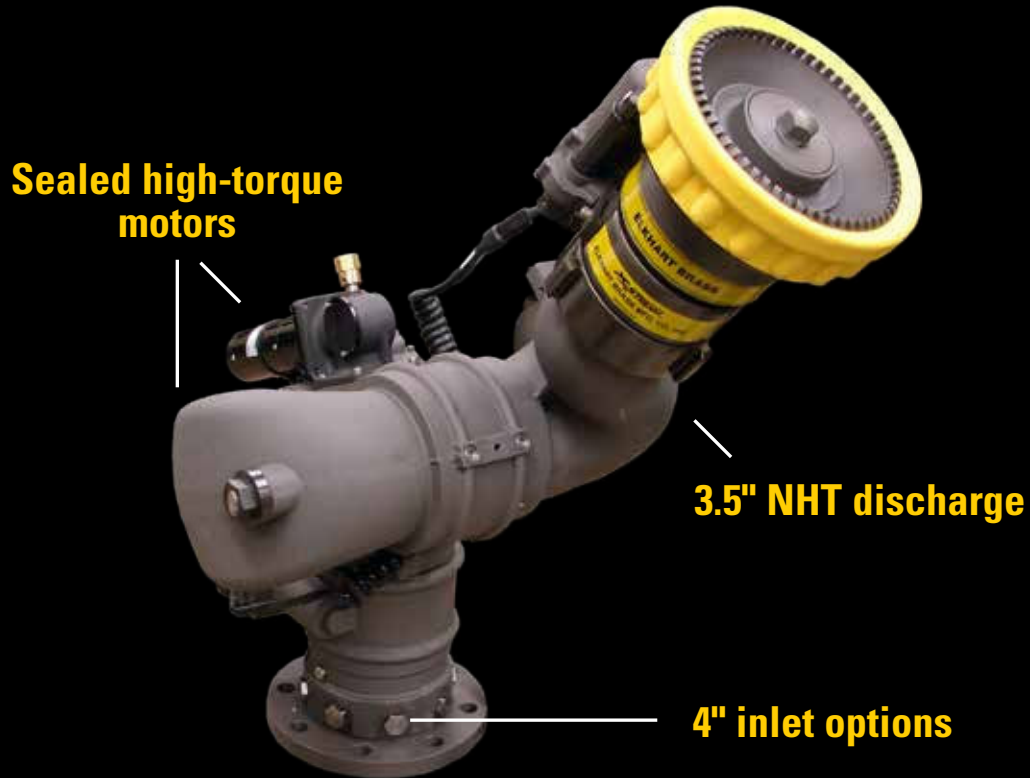

## SPECIFICATIONS

<b>Model:</b>	7400X2
<b>Max Flow:</b>	2500 GPM (10,000 LPM)
<b>Max Pressure:</b>	500 PSI (34.5 bar)
<b>Inlet:</b>	4" ANSI, DN100
<b>Outlet:</b>	3.5" Male NHT & BSPP
<b>Travel:</b>	Vertical: -45° to +90° (135°) Horizontal: L175 to R175 (350°)
<b>Voltage:</b>	12 or 24 VDC compatible
<b>Control:</b>	CANbus J1939
<b>Communication:</b>	915 MHz RF - FCC 868 MHz RF - CE
<b>Material/Finish:</b>	Teflon impregnated, hard anodized Elk-O-Lite®
<b>Stow Height:</b>	20" (508mm)
<b>Weight:</b>	52 lbs (23.6 kg)

## Vehicle Applications

- ARFF
- Industrial Pumper
- Deicing Vehicles



## COMPONENTS & OPTIONS

## MODEL

Electric Nozzles	X-Stream Series Automatic	MODEL	
		3.5" Inlet: 350-1250 GPM (1400-4000 LPM)	SM-1250E
		3.5" Inlet: 500-2000 GPM (2000-8000 LPM)	SM-2000E

# SKYSTREAM™ EXM2 3000 GPM/12,000 LPM

Taking the Scorpion to the next level, the SkyStream EXM2 brings a flow capability of **3000 GPM**. With its 5" outlet, the SkyStream delivers best-in-class flow that provides a reach of up to **400 feet (120 meters)**, making it ideal for fire apparatus, industrial pumpers and aerial vehicles.

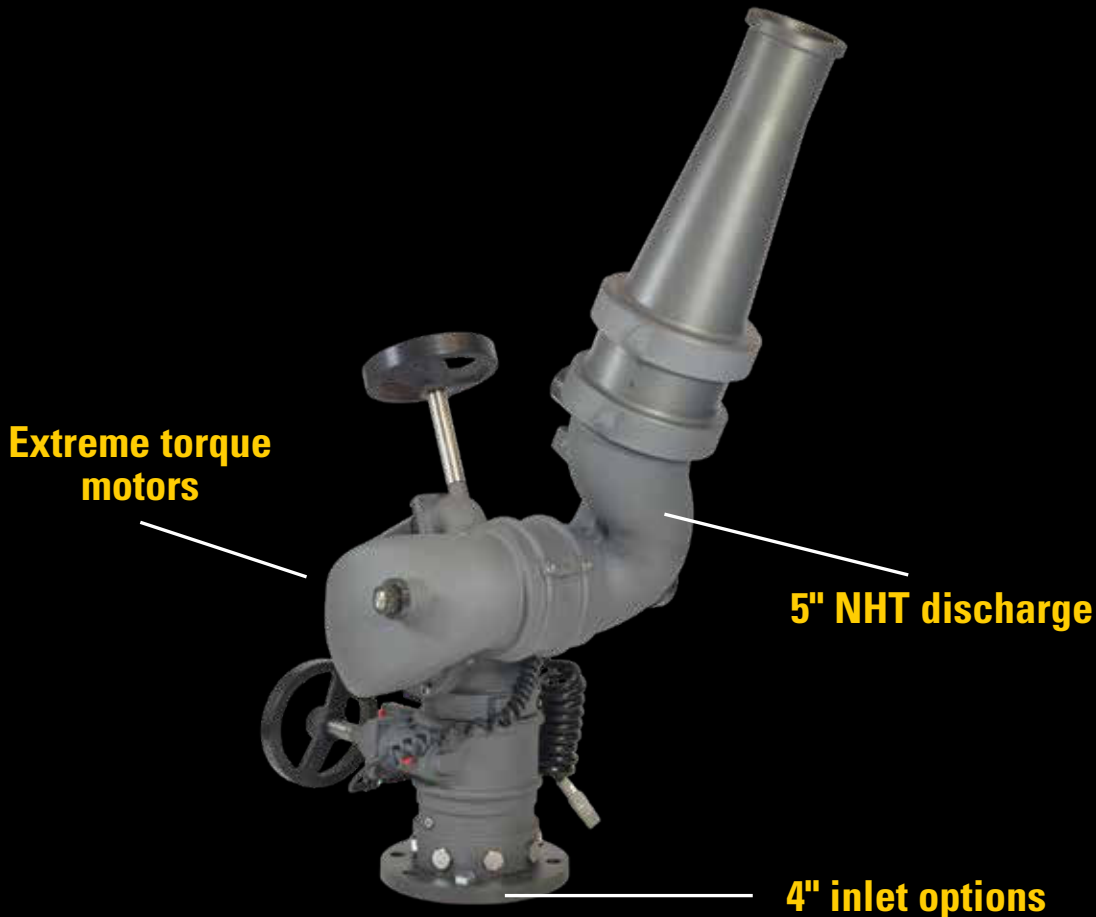

## SPECIFICATIONS

Model:	7500X2
Max Flow:	3000 GPM (12,000 LPM)
Max Pressure:	500 PSI (34.5 bar)
Inlet:	4" ANSI, DN100
Outlet:	5" Male NHT & BSPP
Travel:	Vertical: -45° to +90° (135°) Horizontal: L175 to R175 (350°)
Voltage:	12 or 24 VDC compatible
Control:	CANbus J1939
Communication:	915 MHz RF - FCC 868 MHz RF - CE
Material/Finish:	Teflon impregnated, hard anodized Elk-O-Lite®
Stow Height:	20" (508mm) without optional handwheel
Weight:	58 lbs (26.3 kg)

## Vehicle Applications

- Industrial Pumper
- ARFF



## COMPONENTS & OPTIONS

## MODEL

Nozzles	Smooth Bore	17" long, custom 2 3/4" Smooth Bore Nozzle for use with the SkyStream™ EXM2.	181-5A
---------	-------------	--	--------

# MAGNUM™ EXM2 5000 GPM/20,000 LPM

At only 115 lbs (52kg), the 6" inlet and dual waterway design of the Magnum EXM2 produces **5000 GPM (20,000 LPM)** with just 39 PSI (2.7 bar) of total static pressure drop. The efficient waterway results in a lower inlet pressure requirement while still producing a reach of over **400 feet (120 meters)**.



6" NHT discharge

Sealed high-torque motors

Manual overrides

6" 150# flange

## SPECIFICATIONS

Model:	7600X2
Max Flow:	5000 GPM (20,000 LPM)
Max Pressure:	200 PSI (13.8 bar)
Inlet:	6" 150# Flange
Outlet:	6" NHT
Travel:	Vertical: -60° to +90° (150°) Horizontal: L175 to R175 (350°)
Voltage:	12 or 24 VDC compatible
Control:	CANbus J1939
Communication:	915 MHz RF - FCC 868 MHz RF - CE
Material/Finish:	Teflon impregnated, hard anodized Elk-O-Lite®
Stow Height:	18.6" (472mm)
Weight:	115 lbs (52 kg) including nozzle

## Vehicle Applications

- Industrial Pumper
- Portable Trailers



## SPECIFICATIONS

## MODEL

Electric Nozzles	CM Series Fixed	6" Inlet: 3000 GPM (12,000 LPM)	CM-3000E
		6" Inlet: 5000 GPM (20,000 LPM)	CM-5000E
		6" Inlet: 3000 GPM (12,000 LPM)	CM-3000EX

EXM<sup>2</sup>

**ELKHART BRASS**  
FIRE FIGHTING EQUIPMENT A SAFE FLEET BRAND

[www.elkhartbrass.com](http://www.elkhartbrass.com) • 574.295.8330

