

**Safety Information**

Electrical equipment should be installed, operated, serviced, and maintained only by qualified personnel. No responsibility is assumed by Schneider Electric for any consequences arising out of the use of this material.



**Esmi Impresia Base with Sounder**

Esmi Impresia Base with Sounder (FFS06741016) is an addressable fire base with a built-in sounder and an isolator module in its body. The fire base is designed for installing in addressable fire alarm systems with Esmi ELC loop controller supporting Schneider Electric communication protocol. Esmi Impresia Base with Sounder fire base supports 32 different tone types at two sound levels. The tone type and sound level are programmed from the control panel. The device is compatible for operation with Esmi Impresia addressable detectors series: Esmi Impresia Heat Detector (FFS06741002), Esmi Impresia Smoke Detector (FFS06741001) and Esmi Impresia Multicriteria Detector (FFS06741003). The device is designed for easy installation and consists of two parts: a mounting plane basis and a sounder as a body with a factory mounted fire base. EN 54-3 for indoor use. The address setting is done by the panel, QR code or handheld addressing device. The address range is 1-250.

For more technical information visit [www.se.com](http://www.se.com).

**Installation Instructions**

**Note: Collect the QR code stickers from the devices if QR codes are used for addressing of the devices.**

1. Follow the applicable local and national installation codes and regulations. Choose the proper place for installation of the device.
2. Turn power off the loop circuit before installing the base.
3. Set the module address using programmer or directly from addressable fire panel.
4. Fix the mounting plane basis on the ceiling of the protected premises using fixings according the mounting surface.
5. Run the loop wires and fix the sounder body to the mounting basis using the supplied screws in the spare parts kit.
6. Connect the fire base to the fire panel using the wiring diagram.
7. Insert a detector - Esmi Impresia Heat Detector (FFS06741002), Esmi Impresia Smoke Detector (FFS06741001) and Esmi Impresia Multicriteria Detector (FFS06741003) - into the fire base and rotate clockwise until it drops into place - the short mark on the base fits with that on the sounder body. Continue to rotate the detector until its mark coincides with the long mark on the base - a click is heard.  
*Note: The mounted detector on the Esmi Impresia Standard Base (FFS06741018) with sounder is assigned at different address to the control panel!*
8. Program the sounder parameters.
9. Test the sounder for proper operation.

**Dimensions**

**Installation**

IP21C  
 -10°C ÷ +60°C  
 ~127g

Indoor use

**Technical Specifications**

Operating Voltage Range	16 - 32VDC
Maximal consumption at communication	470 µA @ 27VDC
Maximal consumption:	
- main tone type 27, low volume level	2.8 mA @ 27VDC
- main tone type 27, high volume level*	9.8 mA @ 27VDC
Power volume (main tone type 27): low volume	~ 99dB (A) ± 4dB @ 1m
Power volume (other tone types): low volume	90-100dB ± 3dB @ 1m
Number of tone types	32
Wire Gauge for terminals	0.4mm <sup>2</sup> ÷ 2.0mm <sup>2</sup>
Relative humidity resistance	(93 ± 3)% @ +40°C
Color	White
Material	ABS
Supported communication protocol	Esmi ELC

\* Note: Approved to EN54-3 only!

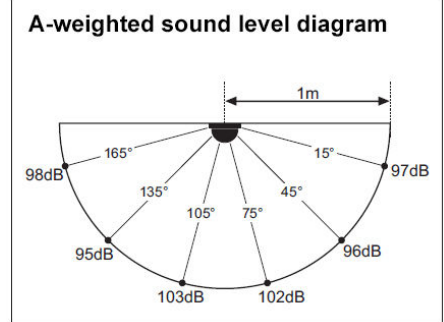

**Isolator Module Technical Specifications**

Maximum line voltage (V <sub>max</sub> )	32V
Nominal line voltage (V <sub>nom</sub> )	28V
Minimum line voltage (V <sub>min</sub> )	16V
Maximum voltage at which the device isolates (V <sub>so max</sub> )*	7.5V
Minimum voltage at which the device isolates (V <sub>so min</sub> )*	5.9V
Maximum voltage at which the device reconnects (V <sub>sc max</sub> **)	6.7V
Minimum voltage at which the device reconnects (V <sub>sc min</sub> **)	5V
Maximum rated continuous current with the switch closed (I <sub>c max</sub> )	0.7A
Maximum rated switching current (e.g. under short circuit) (I <sub>s max</sub> )	1.8A
Maximum leakage current with the switch open (isolated state) (I <sub>l max</sub> )	16mA
Maximum series impedance with the switch closed (Z <sub>c max</sub> )	0.12 Ω @28VDC / 0.15Ω@16VDC

\* Note: Switches from closed to open  
 \*\* Note: Switches from open to closed

<sub>21</sub>  
 1293  
 DoP No: DP20032  
 Made in Bulgaria  
 EN 54-3:2001  
 EN 54-3:2001/A1:2002  
 EN 54-3:2001/A2:2006  
 EN 54-17:2005  
 EN 54-17:2005/AC:2007  
 Sounder Type: A

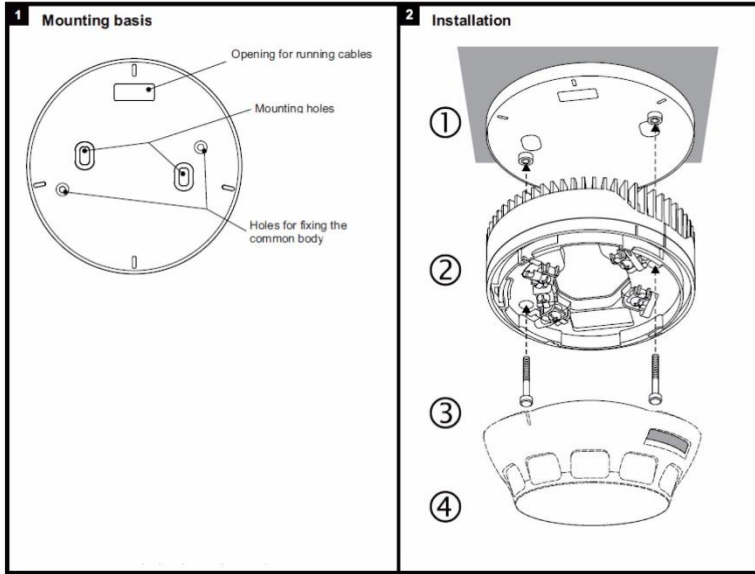

Tone	Tone Type	Tone Description/Application
1		970Hz
2		800Hz/970Hz @ 2Hz
3		800Hz - 970Hz @ 1Hz
4		970Hz 1s OFF/1s ON
5		970Hz, 0.5s/ 630Hz, 0.5s
6		554Hz, 0.1s/ 440Hz, 0.4s (AFNOR NF S 32 001)
7		500 - 1200Hz, 3.5s/ 0.5s OFF (NEN 2575:2000)
8		420Hz 0.625s ON/0.625s OFF (Australia AS1670 Alert tone)
9		500 - 1200Hz, 0.5s/ 0.5s OFF x 3/1.5s OFF (AS1670 Evacuation)
10		550Hz/440Hz @ 0.5Hz
11		970Hz, 0.5s ON/0.5s OFF x 3/ 1.5s OFF (ISO 8201)
12		2850Hz, 0.5s ON/0.5s OFF x 3/1.5s OFF (ISO 8201)
13		1200Hz - 500Hz @ 1Hz (DIN 33 404)
14		400Hz
15		550Hz, 0.7s/1000Hz, 0.33s
16		1500Hz - 2700Hz @ 3Hz
17		750Hz
18		2400Hz
19		660Hz
20		660Hz 1.8s ON/1.8s OFF
21		660Hz 0.15s ON/0.15s OFF
22		510Hz, 0.25s/ 610Hz, 0.25s
23		800/1000Hz 0.5s each (1Hz)
24		250Hz - 1200Hz @ 12Hz
25		500Hz - 1200Hz @ 0.33Hz
26		2400Hz - 2900Hz @ 9Hz
27*		2400Hz - 2900Hz @ 3Hz 2500Hz (main sound frequency)
28		800Hz - 970Hz @ 100Hz
29		800Hz - 970Hz @ 9Hz
30		800Hz - 970Hz @ 3Hz
31		800Hz, 0.25s ON/1s OFF
32		600Hz - 1100Hz, 2.6s/0.4s OFF

\* Note: Approved to EN 54-3 only!

Wiring Diagrams

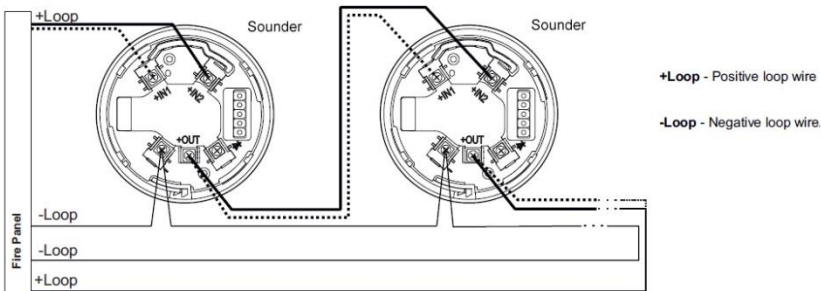

**Legend**  
 — With a detector with a built-in isolator mounted on the sounder fire base  
 ..... With a detector without a built-in isolator mounted on the sounder fire base

Spare Parts

Esmi Impresia Plastic Lid Set of 5 pcs	FFS06741023
--	-------------