

Yuasa Ficha Técnica

Yuasa DCB890-8(ET) Pro-Spec Deep Cycle Battery

Especificaciones

Voltaje nominal (V)	8
5-hr rate Capacity to 10.5V at 20°C (Ah)	155
20-hr rate Capacity to 10.5V at 20°C (Ah)	190
Capacidad a 75A (mins)	90
Capacidad a 25A (mins)	340

Capacidad a 5 HR por Temperatura

40°C	105%
30°C	100%
0°C	80%

Dimensiones

Largo (mm)	262
Ancho (mm)	181
Alto (mm)	245
Alto incluyendo terminales (mm)	276
Peso (Kg)	31.6

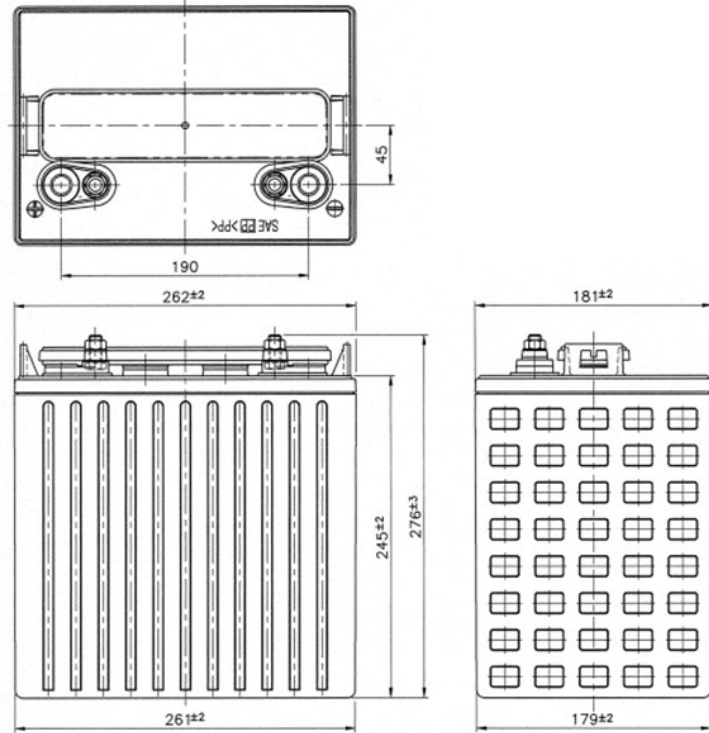

Especificaciones del material

Estilo de la tapa	: Desmontable - Posible mantenimiento
Estilo de la ventilación de la tapa	: Gang style
Material del contenedor y de la tapa	: Plástico de polipropileno negro.
Metodo de sellado de la tapa	: Termosellado
Tipo de conector entre celdas	: Soldadura mediante partición
Metodo de soldado de la placa de lengüeta	: Proceso de montaje automatizado
Material de rejilla positiva	: Aleación de plomo antimonio
Material de rejilla negativa	: Aleación de plomo antimonio

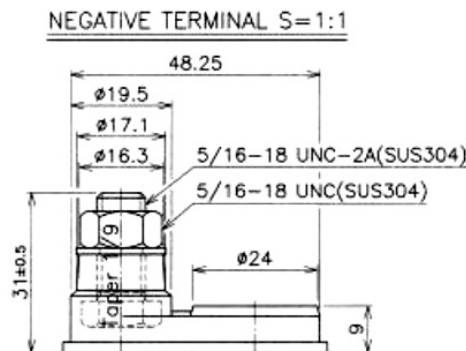
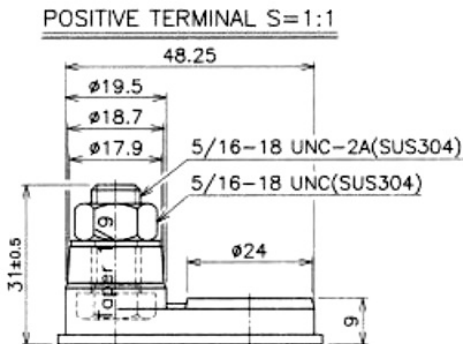

Fecha de emision: 26/11/2022 - E&EO

Yuasa Technical Data Sheet

Yuasa DCB890-8(ET) Pro-Spec Deep Cycle Battery

Specifications

Nominal voltage (V)	8
5-hr rate Capacity to 10.5V at 20°C (Ah)	155
20-hr rate Capacity to 10.5V at 20°C (Ah)	190
Capacity @ 75A (mins)	90
Capacity @ 25A (mins)	340

5-Hr Capacity By Temperature

40°C	105%
30°C	100%
0°C	80%

Dimensions

Length (mm)	262
Width (mm)	181
Height (mm)	245
Height over terminals (mm)	276
Mass (kg)	31.6

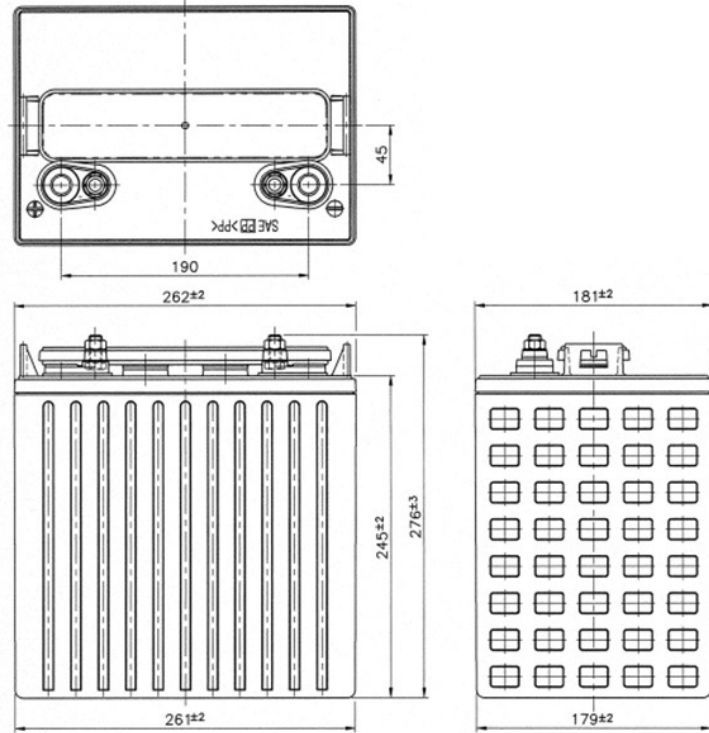

Material Specifications

Cover Style	: Removable - Maintenance Possible
Cover Vent Style	: Gang style
Container & Cover Material	: Black polypropylene plastic
Case to Cover Seal Method	: Heat sealing
Inner Cell Connector Type	: Through-partition weld
Plate Lug Weld Method	: Automated cast-on process
Positive Grid Material	: Antimony lead alloy
Negative Grid Material	: Antimony lead alloy

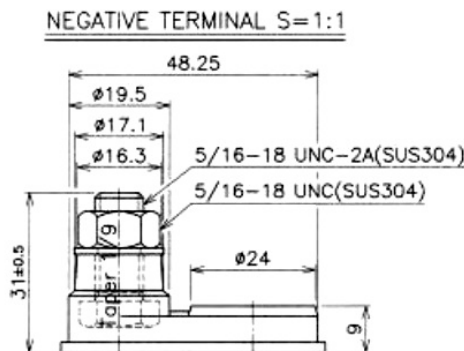
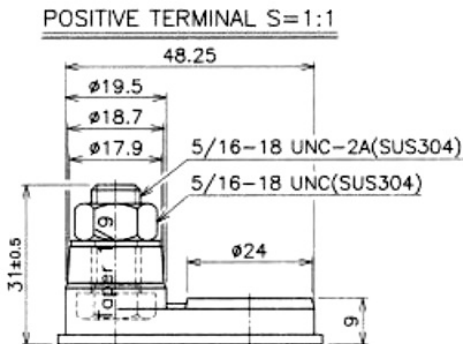

Data Sheet generated on 26/11/2022 - E&OE