

## Yuasa Ficha Técnica

### Yuasa DCB605-6(ET) Pro-Spec Deep Cycle Battery

#### Especificaciones

Voltaje nominal (V)	6
5-hr rate Capacity to 10.5V at 20°C (Ah)	175
20-hr rate Capacity to 10.5V at 20°C (Ah)	210
Capacidad a 75A (mins)	105
Capacidad a 25A (mins)	383

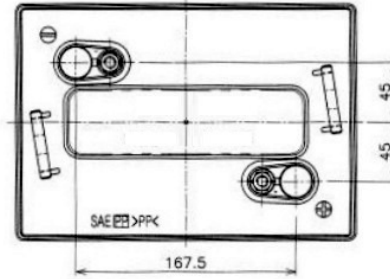

#### Capacidad a 5 HR por Temperatura

40°C	105%
30°C	100%
0°C	80%

#### Dimensiones

Largo (mm)	259
Ancho (mm)	179
Alto (mm)	245
Alto incluyendo terminales (mm)	276
Peso (Kg)	27

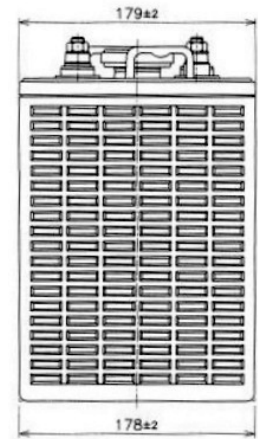
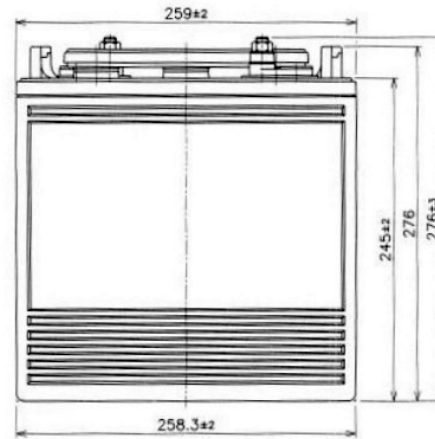

#### Especificaciones del material

Estilo de la tapa	: Desmontable - Posible mantenimiento
Estilo de la ventilación de la tapa	: Gang style
Material del contenedor y de la tapa	: Plástico de polipropileno negro.
Metodo de sellado de la tapa	: Termosellado
Tipo de conector entre celdas	: Soldadura mediante partición
Metodo de soldado de la placa de lengüeta	: Proceso de montaje automatizado
Material de rejilla positiva	: Aleación de plomo antimonio
Material de rejilla negativa	: Aleación de plomo antimonio

POSITIVE TERMINAL S=1:1

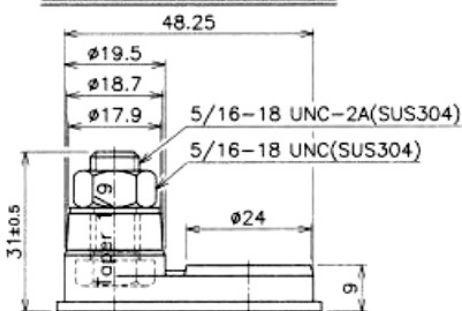

NEGATIVE TERMINAL S=1:1

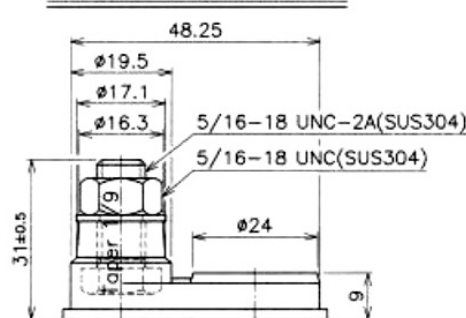

Fecha de emision: 26/11/2022 - E&EO

## Yuasa Technical Data Sheet

### Yuasa DCB605-6(ET) Pro-Spec Deep Cycle Battery

#### Specifications

Nominal voltage (V)	6
5-hr rate Capacity to 10.5V at 20°C (Ah)	175
20-hr rate Capacity to 10.5V at 20°C (Ah)	210
Capacity @ 75A (mins)	105
Capacity @ 25A (mins)	383

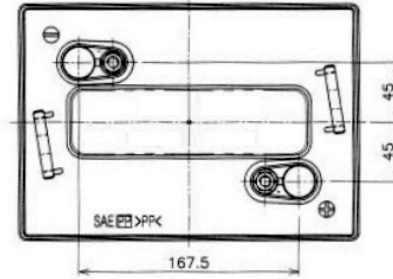

#### 5-Hr Capacity By Temperature

40°C	105%
30°C	100%
0°C	80%

#### Dimensions

Length (mm)	259
Width (mm)	179
Height (mm)	245
Height over terminals (mm)	276
Mass (kg)	27

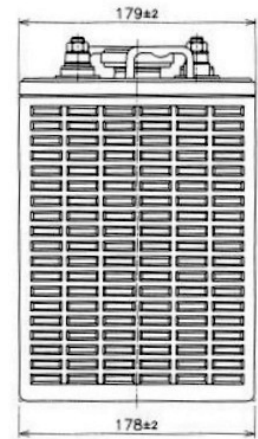
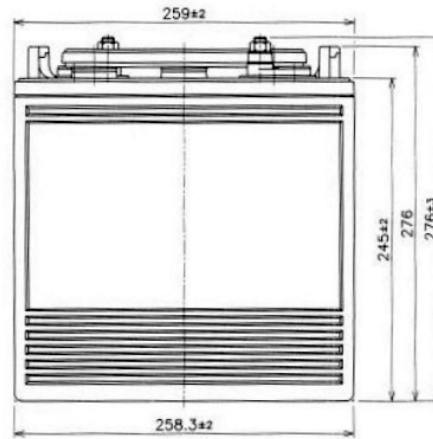

#### Material Specifications

Cover Style	: Removable - Maintenance Possible
Cover Vent Style	: Gang style
Container & Cover Material	: Black polypropylene plastic
Case to Cover Seal Method	: Heat sealing
Inner Cell Connector Type	: Through-partition weld
Plate Lug Weld Method	: Automated cast-on process
Positive Grid Material	: Antimony lead alloy
Negative Grid Material	: Antimony lead alloy

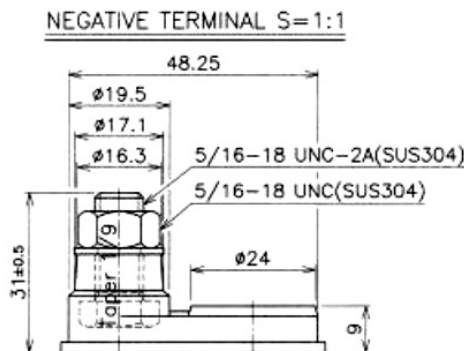
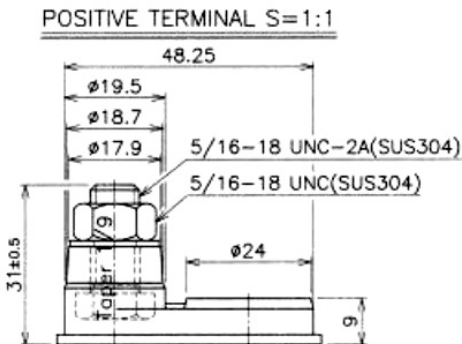

Data Sheet generated on 26/11/2022 - E&OE