



BOSCH

DSA E-Series (E2800 12-bay)

DSA-N2E8X4-12AT | DSX-N1D8X4-12AT | DSA-N2C8X4-12AT |
DSA-N2E8X8-12AT | DSX-N1D8X8-12AT | DSA-N2C8X8-12AT |
DSA-N2E8XC-12AT | DSX-N1D8XC-12AT | DSA-N2C8XC-12AT |
DSA-N2E8XG-12AT | DSX-N1D8XG-12AT | DSA-N2C8XG-12AT



en

Installaton manual

Table of contents

1	Safety	5
1.1	Safety message explanation	5
1.2	Safety precautions	5
1.3	Important safety instructions	5
1.4	Warning notices	7
1.5	Caution notices	8
1.6	Notices	8
2	Introduction	10
2.1	Hardware registration	10
2.2	Additional equipment	10
2.3	Additional documentation	10
3	System overview	11
3.1	Device views	11
3.2	LED description	13
3.2.1	LEDs on the operator display panel	13
3.2.2	LEDs on the controller unit	14
3.2.3	LEDs on the I/O modules	15
3.2.4	LEDs on the drives	16
3.2.5	LEDs on the power-fan canister	17
3.2.6	Seven-segment-display	17
4	Installation	19
4.1	Installing a 2U 12-bay unit	19
4.2	Installing the front bezel and end caps	21
4.3	Setting the unit ID using the ODP button	21
5	Connection	23
5.1	Connecting the expansion units	23
5.1.1	Connecting expansion units to a single controller	23
5.1.2	Connecting expansion units to a dual controller	25
5.2	Connecting the controller unit to the network	26
5.3	Connecting the controller unit to the management hosts	27
5.4	Connecting the units to the power supply	28
5.5	Supported connections	29
6	Turning on/off AC power	32
6.1	Turning on AC power	32
6.2	Turning off AC power	32
7	Configuring the storage system	33
8	Maintenance	35
8.1	Replacing a drive in a 12-bay unit	35
8.1.1	Preparing to replace a drive	36
8.1.2	Removing a drive	36
8.1.3	Installing a drive	37
8.1.4	After replacing a drive	37
8.2	Replacing a power-fan canister	38
8.2.1	Preparing to remove a power-fan canister	39
8.2.2	Removing a power-fan canister	40
8.2.3	Installing a power-fan canister	41
8.2.4	After replacing a power-fan canister	41
8.3	Seven-segment display codes	41

8.3.1	Seven-segment display sequence codes	42
8.3.2	Seven-segment display codes when controller turns on	43
8.3.3	Seven-segment display use cases	43
8.3.4	Seven-segment display lock-down codes	44
8.4	Collecting support data for the storage system	46
9	Support services and Bosch Academy	47

1 Safety

1.1 Safety message explanation

**Notice!**

Indicates a situation which, if not avoided, could result in damage to the equipment or environment, or data loss.

**Caution!**

Indicates a hazardous situation which, if not avoided, could result in minor or moderate injury.

**Warning!**

Indicates a hazardous situation which, if not avoided, could result in death or serious injury.

1.2 Safety precautions

**Caution!**

The Low Voltage power supply unit must comply with EN/UL 60950. The power supply must be a SELV-LPS unit or a SELV - Class 2 unit (Safety Extra Low Voltage - Limited Power Source).

**Caution!**

Installation should only be performed by qualified service personnel in accordance with applicable local codes.

1.3 Important safety instructions

Read, follow, and retain for future reference all of the following safety instructions. Follow all warnings before operating the device.

- Unplug the unit from the outlet before cleaning. Follow any instructions provided with the unit.
- Clean only with a dry cloth. Do not use liquid cleaners or aerosol cleaners.
- Do not install device near any heat sources such as radiators, heaters, stoves, or other equipment (including amplifiers) that produce heat.
- Never spill liquid of any kind on the device.
- Take precautions to protect the device from power and lightning surges.
- Unless qualified, do not attempt to service a damaged device yourself. Refer all servicing to qualified service personnel.
- Install in accordance with the manufacturer's instructions in accordance with applicable local codes.
- Use only attachments/accessories specified by the manufacturer.
- Protect all connection cables from possible damage, particularly at connection points.
- Do not defeat the safety purpose of a polarized or ground-type plug.
- Permanently connected devices must have an external, readily operable mains plug or all-pole mains switch in accordance with installation rules.
- Pluggable devices must have an easily accessible socket-outlet installed near the equipment.

- The plug-socket combination must be accessible at all times, because it serves as the main disconnecting device.
- Any openings in the unit enclosure are provided for ventilation to prevent overheating and ensure reliable operation. Do not block or cover these openings.
- If you install this device in an enclosure, make sure the enclosure is properly ventilated according to the manufacturer's instructions.
- Install the unit only in a dry, weather-protected location.
- Do not use this unit near water, for example near a bathtub, washbowl, sink, laundry basket, in a damp or wet basement, near a swimming pool, in an outdoor installation, or in any area classified as a wet location.
- To reduce the risk of fire or electrical shock, do not expose this unit to rain or moisture.
- Never push objects of any kind into this unit through openings as they may touch dangerous voltage points or short-out parts that could result in a fire or electrical shock.
- Power supply cords should be routed so that they are not likely to be walked on or pinched by items placed upon or against them, paying particular attention to cords and plugs, convenience receptacles, and the point where they exit from the appliance.
- Operate the unit only from the type of power source indicated on the label. Use only the power supply provided or power supply units with UL approval and a power output according to LPS or NEC Class 2.
- Do not open or remove the cover to service this unit yourself. Opening or removing covers may expose you to dangerous voltage or other hazards. Refer all servicing to qualified service personnel.
- Be sure the service technician uses replacement parts specified by the manufacturer. Unauthorized substitutions could void the warranty and cause fire, electrical shock, or other hazards.
- Do safety inspections after service or repairs to the device to make sure the device operates properly.
- Observe the relevant electrical engineering regulations.
- When installing in a switch cabinet, ensure that the unit and the power supply units have sufficient grounding.
- Connect the unit to an earthed mains socket.
- Use proper CMOS/MOS-FET handling precautions to avoid electrostatic discharge (ESD).
- For protection of the device, the branch circuit protection must be secured with a maximum fuse rating of 16 A. This must be in accordance with NEC800 (CEC Section 60).
- Disconnect the power before moving the unit. Move the unit with care. Excessive force or shock may damage the unit and the hard disk drives.
- All the input/output ports are Safety Extra Low Voltage (SELV) circuits. SELV circuits should only be connected to other SELV circuits.
- If safe operation of the unit cannot be ensured, remove it from service and secure it to prevent unauthorized operation. In such cases, have the unit checked by Bosch Security Systems.
- Disconnect power supply and arrange for the device to be serviced by qualified personnel in the following cases, because safe operation is no longer possible:
 - The power cable/plug is damaged.
 - Liquids or foreign bodies have entered the device.
 - The device has been exposed to water or extreme environmental conditions.
 - The device is faulty despite correct installation/operation.
 - The device has fallen from a height, or the housing has been damaged.
 - The device was stored over a long period under adverse conditions.

- The device performance is noticeably changed.
- Installation of the unit must comply with local and national electrical codes.
- Cluster media converters must be installed in a restricted access location.
- When installing the unit into a movable cabinet or rack, install from the bottom up for best stability.
- Use only manufacturer’s supplied power cords and cables with manufacturer equipment.
- DC-based systems must be installed in a restricted access location and the two input power terminals for the DC power supply must be connected to separate isolated branch circuits.
- A qualified service person is required to make the DC power connection according to local and national electric codes / guidelines.
- Ensure your DC mains supply is earthed at the point of generation per IEC 60950-1.
- To reduce the risk of personal injury or equipment damage, allow internal components time to cool before touching them.
- Ensure that the equipment is properly supported or braced when installing options.
- This equipment is designed for connection to a grounded outlet. The grounding type plug is an important safety feature. To avoid the risk of electrical shock or damage to the equipment, do not disable this feature.
- Risk of electrical shock - If there is evidence of fire, water, or structural damage, never turn on the power to the equipment.
- Risk of electrical shock - Before removing or installing a power supply, turn off the power switch, and unplug the power cord.
- Pinching hazard - As you push the canister into the slot, ensure that your fingers are not pinched between the lever and the canister. The lever automatically moves toward the closed position as the canister is pushed into its slot.
- Do not remove more than one canister from the enclosure while power to the enclosure is turned on.
- Bosch products may contain Class 1 laser devices, Class 1M laser devices, or both.
- Keep away from moving fan blades.
- Do not use equipment in the cabinet as a shelf or work space.

1.4 Warning notices

This product relies on the building’s installation for short-circuit (overcurrent) protection. Ensure that a fuse or circuit breaker no larger than 120 VAC, 20A U.S. (240 VAC, 16A international) is used on the phase conductors (all current-carrying conductors).



Warning!

High leakage current. Earth connection essential before connecting supply.



Warning!

To prevent personal injury or damage to the unit, never attempt to lift or tilt the unit using the handles of controller modules, power supplies, fans, and so on. These types of handles are not designed to support the weight of the unit.



Warning!

An electrical outlet that is not correctly wired could place hazardous voltage on metal parts of the system or the devices that attach to that system. It is the customer’s responsibility to ensure that the outlet is correctly wired and grounded to prevent an electrical shock.

**Warning!**

To prevent electrical shock hazard, disconnect all power cables from the electrical outlet before relocating the system.

**Warning!**

Risk of bodily injury, A lead-acid battery can weigh up to 10.9kg (24.1lb). When you remove this type of battery, be prepared to support its weight. If the battery is dropped, the impact might cause bodily injury, including deep puncture wounds caused by the battery pins.

**Warning!**

For Class 1M laser products

Laser radiation. Do not view directly with optical instruments. Viewing the laser output with certain optical instruments (for example, eye loupes, magnifiers, and microscopes) within a distance of 100 mm might pose an eye hazard. Use of controls or adjustments or performance of procedures other than those specified herein might result in hazardous radiation exposure. Do not disassemble or remove any part of a small form-factor pluggable (SFP) transceiver because you might be exposed to laser radiation.

1.5**Caution notices****Caution!**

The battery used in this device might present a risk of fire, explosion, or chemical burn if mistreated. DO NOT crush or puncture, short circuit external contacts, disassemble, dispose of in fire or water, heat above maximum temperature limit, or incinerate.

**Caution!**

DOUBLE POLE/NEUTRAL FUSING

**Caution!**

To avoid personal injury, before lifting this unit, remove all appropriate subassemblies per instructions to reduce the system weight.

**Caution!**

Equipment weighing less than 18 kg (39.7 lbs) can be lifted by one person.

Equipment weighing equal to or more than 18 kg (39.7 lbs) and less than 32 kg (70.5 lbs) requires two people to lift.

Equipment weighing equal to or more than 32 kg (70.5 lbs) and less than 55 kg (121.2 lbs) requires three people to lift.

Equipment weighing equal to or more than 55 kg (121.2 lbs) and less than 72 kg (158.7 lbs) requires four people to lift.

Equipment weighing equal to or more than 72 kg (158.7 lbs) requires a lifting device.

1.6**Notices****Notice!**

This is a **class A** product. In a domestic environment this product may cause radio interference, in which case the user may be required to take adequate measures.



Notice!

Video loss is inherent to digital video recording; therefore, Bosch Security Systems cannot be held liable for any damage that results from missing video information.
To minimize the risk of losing information, we recommend multiple, redundant recording systems, and a procedure to back up all analog and digital information.

	<p>Disposal</p> <p>Your Bosch product has been developed and manufactured using high-quality materials and components that can be reused. This symbol means that electronic and electrical devices that have reached the end of their working life must be disposed of separately from household waste.</p> <p>In the EU, separate collecting systems are already in place for used electrical and electronic products. Please dispose of these devices at your local communal waste collection point or at a recycling center.</p>
--	--



Notice!

Do not dispose batteries in household waste. Dispose of batteries only at suitable collection points and, in the case of lithium batteries, mask the poles.



Caution!

Battery replacement - For qualified service personnel only

A lithium battery is located inside the unit enclosure. To avoid danger of explosion, replace the battery as per instructions. Replace only with the same or equivalent type recommended by the manufacturer. Dispose of the replaced battery in an environmentally friendly way and not with other solid waste. Refer all servicing to qualified service personnel.

	<p>Do not place this unit on an unstable stand, tripod, bracket, or mount. The unit may fall, causing serious injury and/or serious damage to the unit.</p>
--	---

Information on sales, delivery, storage, and working life period

No restrictions or conditions apply for the sale or delivery of this product.
If stored under the specified conditions, the storage period is not restricted.
If used for the specified purpose in compliance with the safety instructions and technical specifications, the working life period of the product is in accordance with normal expectations for this type of product.

Information on equipment use

Device is for professional installation only. Operation of the devices is not intended for personal or household use. There are no restrictions to use the device in commercial and industrial areas, except those mentioned in the Safety information.

2 Introduction

This manual is written for professional system integrators and PC technicians. It provides information for the installation of the chassis. The installation should be done by experienced and qualified technicians only.

Before you start the installation, read and follow the safety instructions.

2.1 Hardware registration

We recommend that you register your device. If you already have an existing NetApp NOW account, add your device to it. If you have no NetApp NOW account, create a new account using the Bosch Product Registration page.

Registering your device using an existing NetApp NOW account

Sign in to your NetApp NOW account and register your device [here](#).

Creating a new account using the Bosch Product Registration page

Please register your product:

<https://www.boschsecurity.com/product-registration/>



2.2 Additional equipment

You may need the following equipment:

- A Phillips No. 2 and a medium flat-blade screwdriver
- An ESD wrist strap
- An Ethernet switch or network hub
- Ethernet cables
- Management station or personal computer

2.3 Additional documentation

More information

For more information, software downloads, and documentation, go to www.boschsecurity.com and the corresponding product page.

3 System overview

3.1 Device views

12-bay controller unit or expansion unit - front view

(Front view of the single controller unit, dual controller unit, or expansion unit)



1

2

1	Status displays	2	Drive canister
----------	-----------------	----------	----------------

12-bay single controller unit - rear view

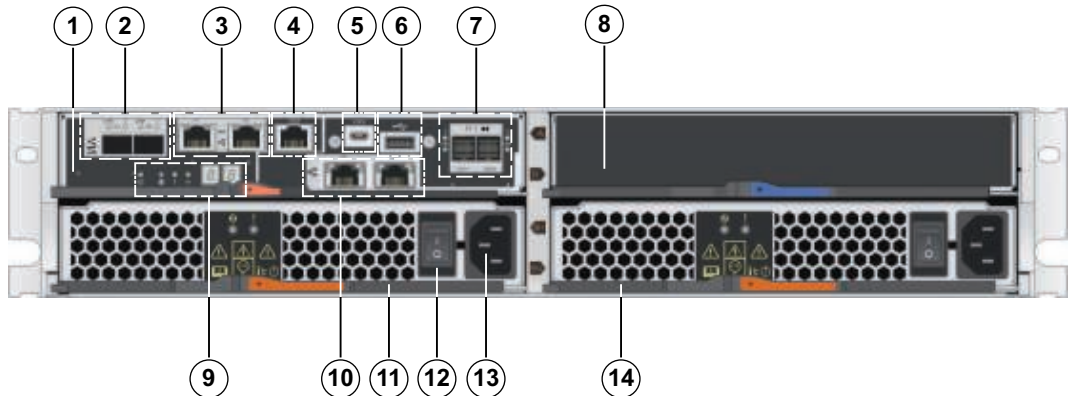

1

2

3

4

5

6

7

8

9

10

11

12

13

14

1	Controller canister	2	Channel 3 (left) / Channel 4 (right) - Host interface ports (Dual 10 GB iSCSI, optical) Note: Use only RJ45 Base-T ports or optical ports.
3	Management port 1 (left) / Management port 2 (right) - Dual 1 Gigabit Ethernet Note: Use only Port 1 per controller (default).	4	Serial port (RJ45)
5	Serial port (micro USB)	6	USB port (only for factory use)
7	Dual 12 Gb SAS drive expansion ports	8	Empty
9	Status display	10	Channel 5 (left) / Channel 6 (right) - Host interface ports (Dual 10 GB iSCSI, RJ45 Base-T) Note: Use only RJ45 Base-T ports or optical ports.
11	Power-fan canister 1	12	On/off switch

13 Mains connection 100 - 240 VAC	14 Power-fan canister 2
--	--------------------------------

12-bay dual controller unit - rear view

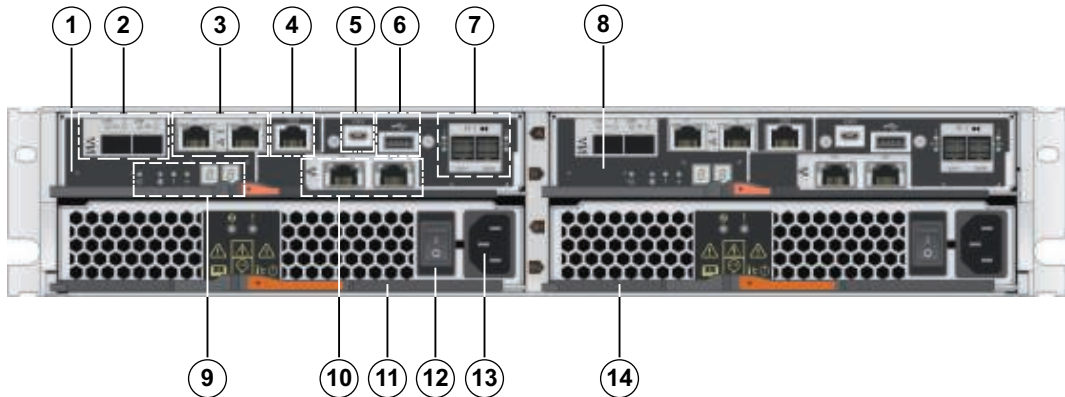

1 Controller A	2 Channel 3 (left) / Channel 4 (right) - Host interface ports (Dual 10 GB iSCSI, optical) Note: Use only RJ45 Base-T ports or optical ports.
3 Management port 1 (left) / Management port 2 (right) - Dual 1 Gigabit Ethernet Note: Use only Port 1 per controller (default).	4 Serial port (RJ45)
5 Serial port (micro USB)	6 USB port (only for factory use)
7 Dual 12 Gb SAS drive expansion ports	8 Controller B (see Controller A)
9 Status display	10 Channel 5 (left) / Channel 6 (right) - Host interface ports (Dual 10 GB iSCSI, RJ45 Base-T) Note: Use only RJ45 Base-T ports or optical ports.
11 Power-fan canister 1	12 On/off switch
13 Mains connection 100 - 240 VAC	14 Power-fan canister 2

12-bay expansion unit - rear view

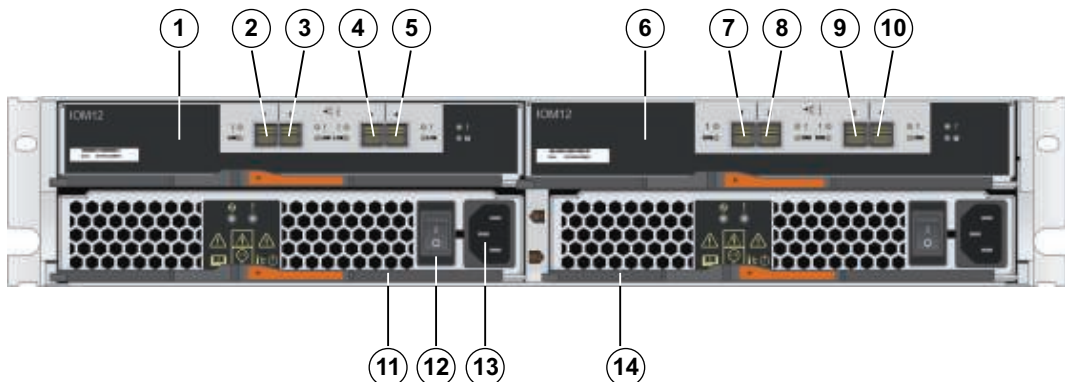

1	IOM A	2	IOM A - SAS port 1
3	IOM A - SAS port 2	4	IOM A - SAS port 3
5	IOM A - SAS port 4	6	IOM B
7	IOM B - SAS port 1	8	IOM B - SAS port 2
9	IOM B - SAS port 3	10	IOM B - SAS port 4
11	Power-fan canister 1	12	On/off switch
13	Mains connection 100 - 240 VAC	14	Power-fan canister 2

3.2 LED description

There are several LEDs on the front and rear of the chassis. The LEDs show the over-all status of the system and the activity and health of specific components.

3.2.1 LEDs on the operator display panel

Each controller unit and expansion unit has LEDs located on the operator display panel. The operator display panel is visible through the front bezel of a controller unit and through the left end cap of an expansion unit.



1	Power LED	2	Attention LED
3	Locate LED	4	7-segment display
5	Drive canister		

The following table describes the LEDs and their operational states:

LED	Status indicator	Description
Power	Green	One or more power supplies are supplying power to the unit.
	Off	The unit is not receiving power.
Attention	Amber	There is an error with the function of one or more of the following: <ul style="list-style-type: none"> - Unit - Drives - IOMs - Power supplies - Fans
	Off	The unit, drives, IOMs, power supply, and fans are functioning correctly.

LED	Status indicator	Description
Locate	Blue	There is an active request to physically locate the shelf. Note: The Locate LED turns off automatically after 30 minutes.

3.2.2 LEDs on the controller unit

The back of the controller unit includes LEDs that indicate the status of the controller. For example, the controller is active, the controller needs attention, or when there is Ethernet activity.

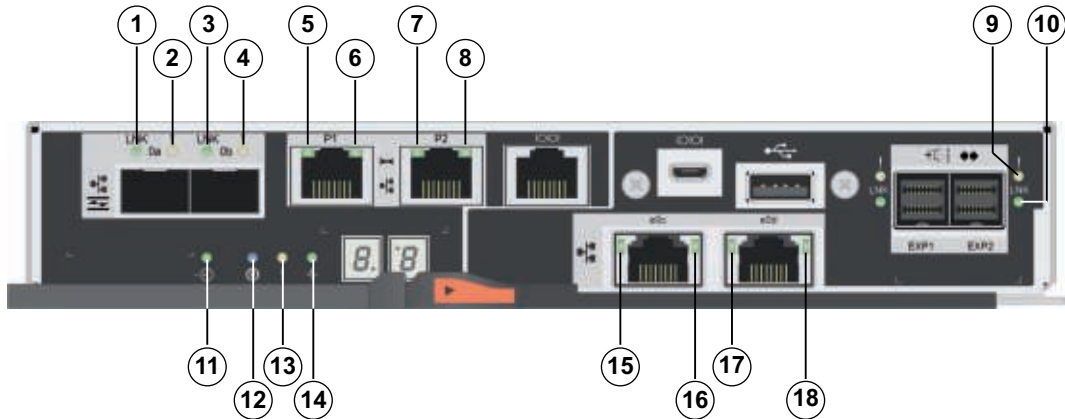

1	Channel 3 - host port link status LED	2	Channel 3 - host port attention LED
3	Channel 4 - host port link status LED	4	Channel 4 - host port attention LED
5	Management port 1 - Ethernet status LED	6	Management port 1 - Ethernet activity LED
7	Management port 2 - Ethernet status LED	8	Management port 2 - Ethernet activity LED
9	SAS drive expansion port - attention LED	10	SAS drive expansion port - link status LED
11	Cache active LED	12	Locate LED
13	Attention LED	14	Activity LED

The following table describes the LEDs and their operational states:

LED	Status indicator	Description
Cache active	Green	The cache contains data not yet written to disk.
	Off	Either the cache is inactive or all data from the cache has been preserved in non-volatile memory.
Locate	Blue	There is an active request to physically locate the controller unit.
	Off	There is no active request to locate the controller unit.

LED	Status indicator	Description
Attention	Amber	The controller is faulty and requires operator attention, and the faulty component is serviceable.
	Off	The controller is operating normally.
Activity	Blinking green	The controller is active.
Ethernet activity (right)	Green	The link between the management port and the device to which it is connected (such as an Ethernet switch) is up.
	Off	There is no link between the controller and the connected Ethernet port.
	Blinking green	There is Ethernet activity.
Ethernet link state (left)	Green	Link is established.
	Off	No link is established.
SAS expansion port link	Green	Link is established.
	Off	No link is established.
SAS expansion port link fault	Amber	Port is degraded (one or more physical devices in the port are down).
	Off	Port is optimal. All physical devices in the port are up or all physical devices in the port are down since the LED is off if no cables are attached.
Host port link status (SFP host port, FC or iSCSI)	Green	The link is up (Fibre channel). LED is solid: The link is up, but there is no activity (iSCSI). LED is flashing: The link is up and there is activity (iSCSI). LED is off: The link is down.
Host port attention (SFP host port, FC or iSCSI)	Amber	The port requires operator attention.
Host port link status (RJ-45 host port, iSCSI)	Green	LED is on: The link is established. LED is off: No link is established.
Host port activity (RJ-45 host port, iSCSI)	Green	LED is on: The link is up with no activity. LED is blinking: There is link activity. LED is off: No link is established.

3.2.3 LEDs on the I/O modules

The I/O module (IOM) includes the SAS ports for connecting the expansion units to the controller units or to other expansion units.

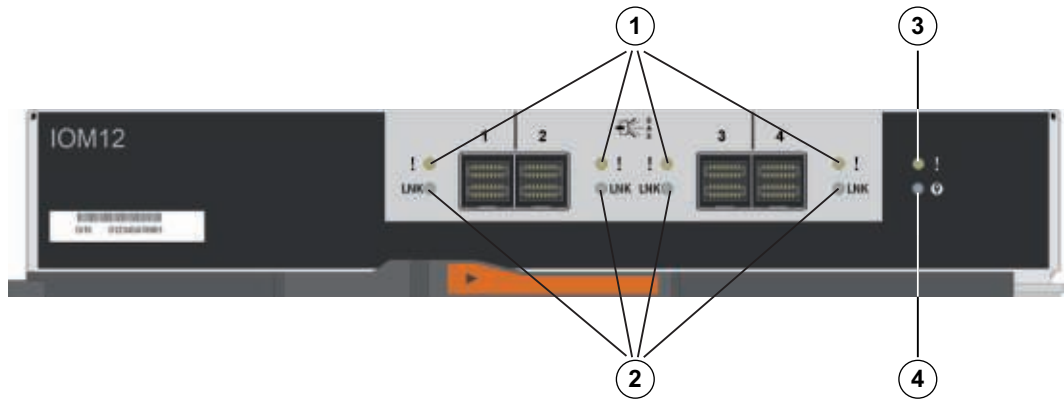

1	SAS port attention LED	2	SAS port link LED
3	IOM attention LED	4	IOM locate LED

The following table describes the LEDs and their operational states:

LED	Status indicator	Description
Attention	Amber	The IOM is not functioning correctly.
	Off	The IOM is functioning correctly.
Locate	Blue	There is an active request to physically locate the expansion unit. Note: When the Locate LED is activated, the Locate LED on the left end cap of the expansion unit is also activated. The Locate LEDs turn off automatically after 30 minutes.
	Off	There is no active request to locate the expansion unit.
SAS port link	Green	The SAS port established a link (with either a controller or another expansion unit).
	Off	No link is established to another SAS port.
SAS port attention	Amber	One or more of the links in the port are not working properly.
	Off	The port is optimal and no link error has occurred.

3.2.4 LEDs on the drives

The drives that are installed in the controller unit and the expansion unit include an Activity LED and an Attention LED.



1	Activity LED	2	Attention LED
----------	--------------	----------	---------------

The following table describes the LEDs and their operational states:

LED	Status indicator	Description
Activity	Green	The drive has power.
	Blinking green	The drive has power, and I/O is in process.
Attention	Amber	An error occurred with the functioning of the drive.

3.2.5 LEDs on the power-fan canister

The power-fan canister has LEDs and its own power switch and power outlet. Each 12-bay controller unit and 12-bay expansion unit has two of these canisters.

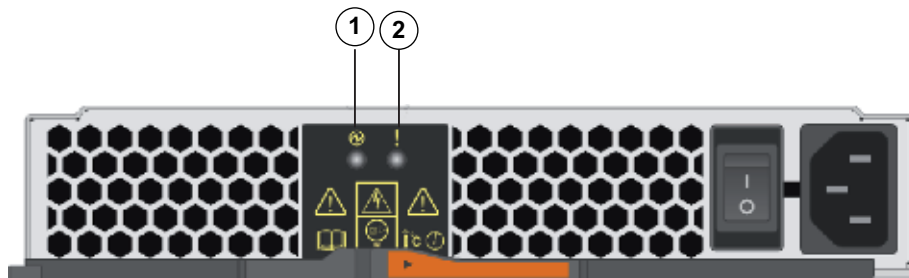

1	Power LED	2	Attention LED
----------	-----------	----------	---------------

The following table describes the LEDs and their operational states:

LED icon	LED name	Status indicator	Description
Ⓜ	Power	Steady green	The power supply is functioning correctly.
		Off	The power supply failed, the AC switch is turned off, the AC power cord is not properly installed, or the AC power cord input voltage is not within margin (there is a problem at the source end of the AC power cord).
!	Attention	Steady amber	The power supply or its integrated fan has a fault.

3.2.6 Seven-segment-display

Each controller unit has a two-digit, seven-segment display at the back, which shows the controller state.

Controller state	Seven-segment-display
Functioning correctly	Tray ID
Not functioning correctly	Diagnostic codes to help identify errors.

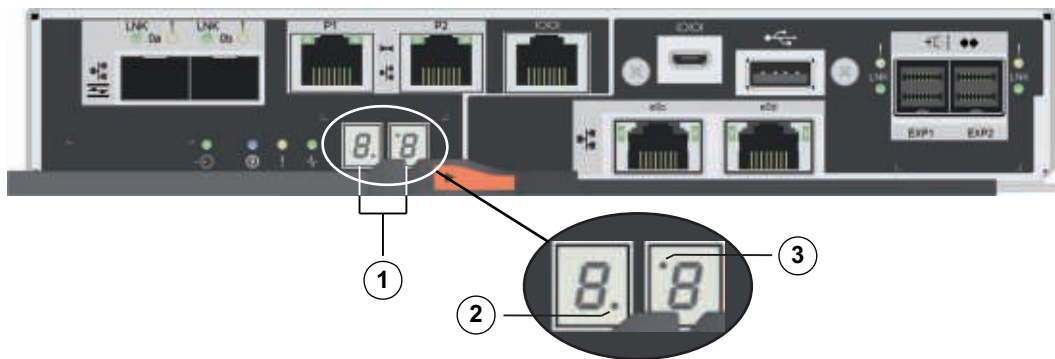

1	Tray ID	2	Heartbeat (dot in the lower right)
3	Diagnostic (dot in the upper left)		

The following table describes the LEDs and their operational states:

LED	Status indicator	Description
Tray ID	Green	Shows the ID of the controller unit when the controller operates normally. If the controller is not operating normally and the Diagnostic LED is on, the diagnostic code is displayed instead.
Heartbeat	Blinking green	Indicates normal activity.
Diagnostic	Green	The seven-segment display shows the diagnostic code.
	Off	The seven-segment display shows the tray ID.

4 Installation

4.1 Installing a 2U 12-bay unit

You can install the unit in a four-post rack or system cabinet.

Observe the following:

- You can install the unit in either a square-hole or round-hole rack.
- If you are installing the unit in a cabinet not provided by Bosch, you must calculate the thermal output of your equipment and compare the results with the target system cabinet's thermal rating. You might need to remove the system cabinet doors to improve airflow through the system cabinet.

For thermal rating information refer to the rack or system cabinet manuals provided by the manufacturer.

- You must use only the screws that are provided in the kit.



Notice!

When installing the units, load the cabinet so as not to make it top-heavy. One approach is to place the controller-unit in the middle portion of the cabinet while allowing room for expansion units to be placed above and below the controller unit.

To install a 12-bay controller or expansion unit:

1. Determine where you want to install the unit in the rack or system cabinet.

Note: Whenever possible, install the units from the bottom of the rack up, so that you can use the units underneath as a guide for installing the next set of rails.
2. Attach the rails to the rack or system cabinet as follows:
 - Place the rail inside the rack or system cabinet where you want to install the unit. Align the alignment screws on the rail with the holes on the front post of the rack.
 - If you have a round-hole rack, remove the eight preinstalled square-hole rack alignment screws and install the eight round-hole rack alignment screws.

Note: Ensure that you use the screws that are appropriate for your rack.
 - Extend the rail to the back post of the rack or system cabinet until the flanges on the rail touch the inside of the rack or system cabinet.
 - Insert one M5 screw through the hole in the front of the rack or system cabinet, and two M5 screws through the holes at the back of the rack or system cabinet.
 - Repeat these steps for the other rail.

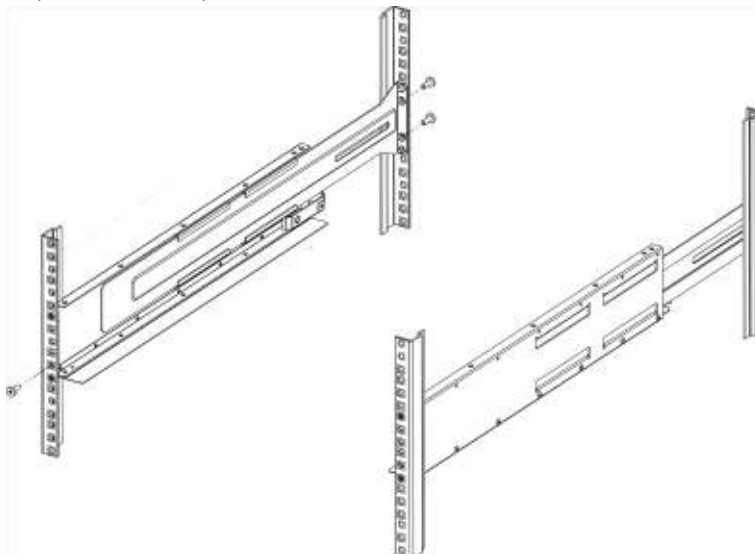

3. Place the back of the unit (the end with the connectors) on the rails.

Caution: A fully loaded unit weighs approximately 65 lb (29 kg). Two persons or a mechanical lift are required to safely move the unit.

- 4. Carefully slide the unit all the way onto the rails.

Note: If applicable, you might need to remove the end caps or the system bezel to secure the unit to the rack post. Replace the end caps or bezel when you are done.

Note: You might need to adjust the rails to ensure that the unit slides all the way onto the rails.

Note: Do not place additional equipment on the rails after you finish installing the unit. The rails are not designed to bear additional weight.

- 5. Secure the unit to the front of the rack or system cabinet and rails by inserting two M5 screws through the mounting brackets (preinstalled on either side of the front of the unit), the holes on the rack or system cabinet, and the holes on the front of rails.

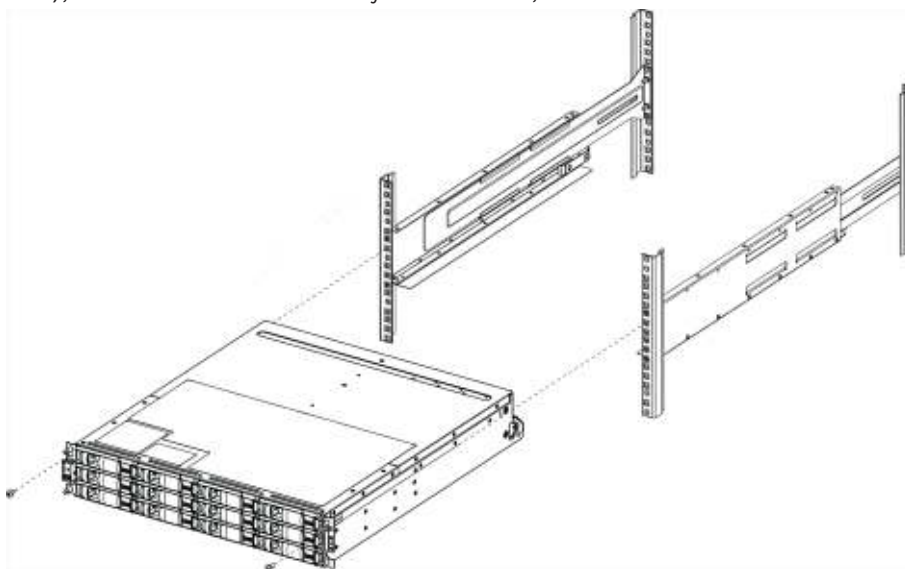

- Secure the unit to the back of the rails by inserting two M5 screws through the brackets at the unit and the rail kit bracket.

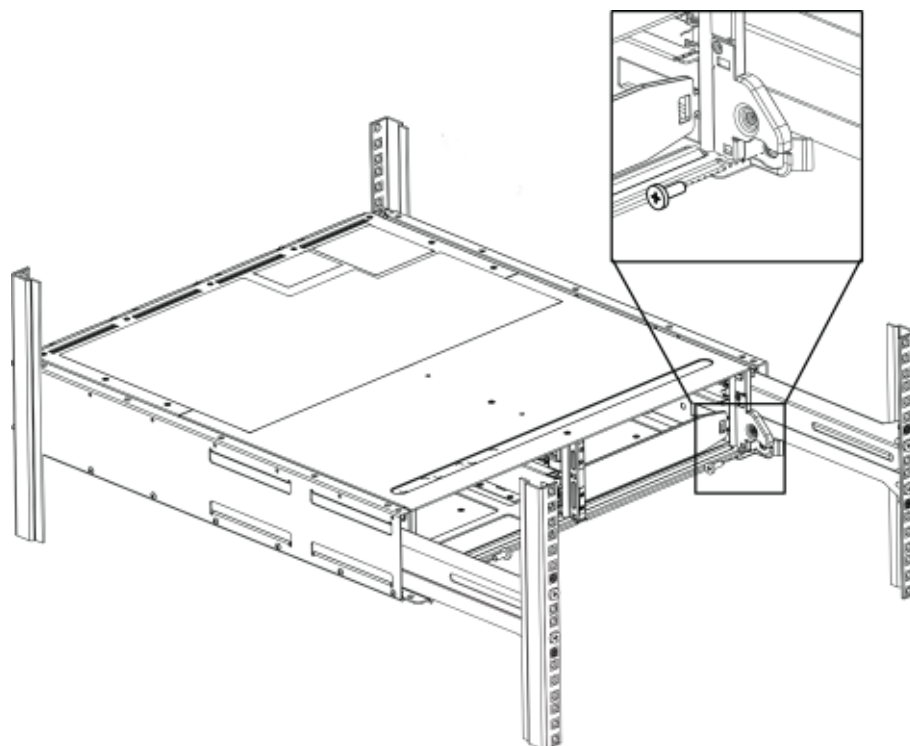

- If applicable, replace the end caps or the system bezel.

Note: Additional documentation can be found on the Bosch online catalog.



Notice!

Install the expansion units below and above the controller unit, keeping the weight in the lower portion of the cabinet.

4.2

Installing the front bezel and end caps

A front bezel covers the front of the controller unit and the expansion unit, while left and right end caps cover the mounting flanges on each unit.

To install the front bezel:

- Position the front bezel in front of the controller unit or the expansion unit so that the holes at each end align with the fasteners on the unit.
- Snap the bezel into place.

To install the end caps:

- Position the left end cap in front of the controller unit or the expansion unit so that the holes in the end cap align with the fasteners on the left side of the unit.
- Snap the end cap into place.
- Repeat these steps for the right end cap.

4.3

Setting the unit ID using the ODP button

You can set or change the unit ID for a controller unit or a expansion unit by using the operator display panel (ODP) button.

Before you begin

You might need to remove the front bezel or the end cap to see the ODP button.

About this procedure

The following figure shows the operator display panel (ODP) button on the controller unit and the expansion unit.



1	Operator display panel (ODP) button
----------	-------------------------------------

To set the unit ID with the ODP button:

1. Turn on the unit.
2. Press and hold the ODP button until the first number on the seven-segment display starts to blink.

Note: It can take up to three seconds for the number to blink. If the number does not blink in this time, release the button and press it again. Make sure to press the button all the way in.

3. Change the first number of the unit ID by repeatedly pressing the ODP button to advance the number until you reach the desired number from 0 to 9.
The first number continues to blink.
4. Press and hold the ODP button until the second number on the digital display starts to blink.

Note: It can take up to three seconds for the second number to blink. The first number on the seven-segment display stops blinking.

5. Change the second number of the unit ID by repeatedly pressing the ODP button to advance the number until you reach the desired number from 0 to 9.
The second number continues to blink.
6. Lock in the desired number, and exit the programming mode by pressing and holding the ODP button until the second number stops blinking.

Note: It can take up to three seconds for the second number to stop blinking.

5 Connection

5.1 Connecting the expansion units

The expansion units are shipped with the appropriate number of SAS cables.

To connect the components:

- Connect the SAS cable from the SAS port on the controller unit to the SAS port on the expansion unit.
- To connect a single controller to multiple expansion units, use the same cabling as for dual controller but ignore the cabling from Controller B.



Notice!

You can connect a 12-bay DSA E2800 controller unit to a maximum of seven 12-bay DSA E2800 expansion units.

5.1.1 Connecting expansion units to a single controller

One expansion unit - single controller configuration

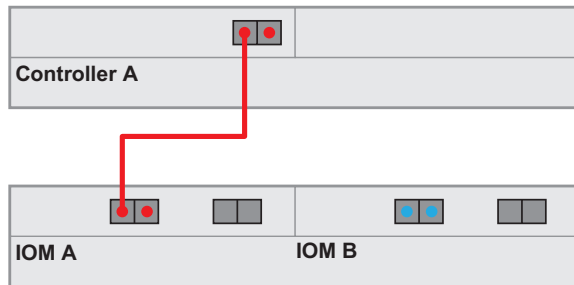

Three expansion units - single controller configuration

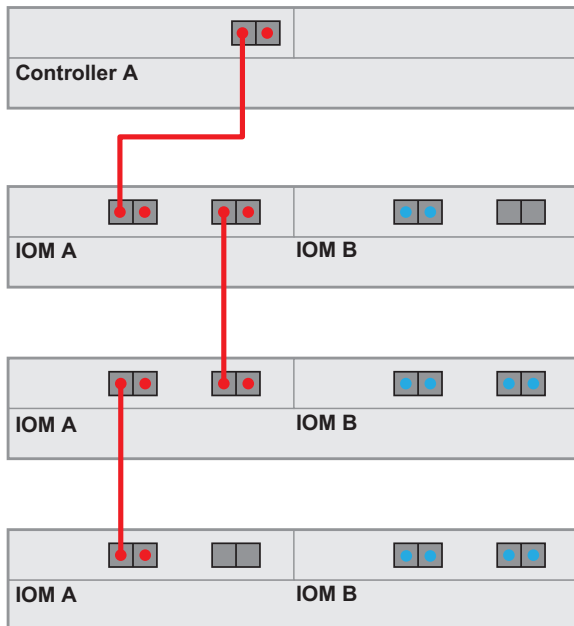

Maximum number of expansion units - single controller configuration

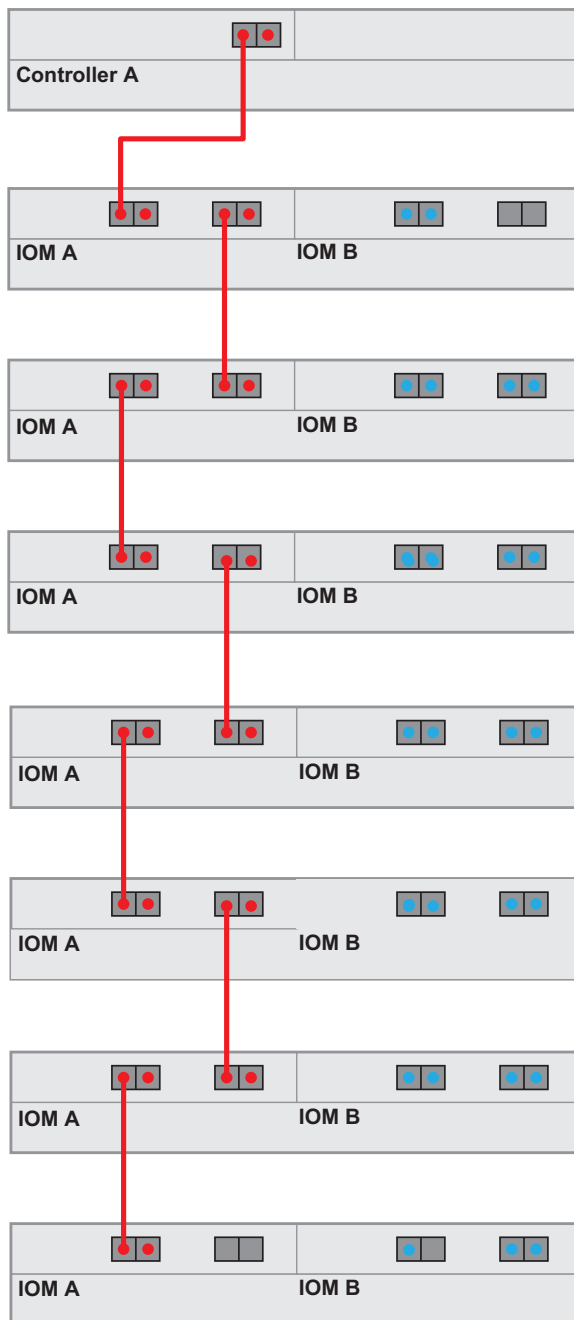

5.1.2 Connecting expansion units to a dual controller

One expansion unit - dual controller configuration

(recommended cabling for maximum throughput)

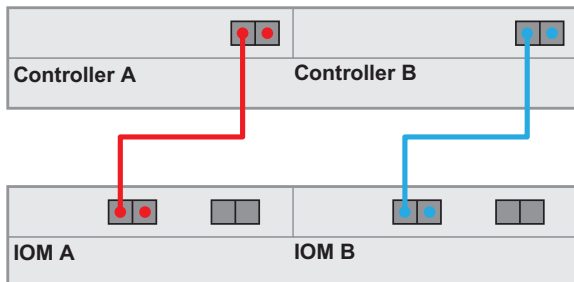

Three expansion units - dual controller configuration

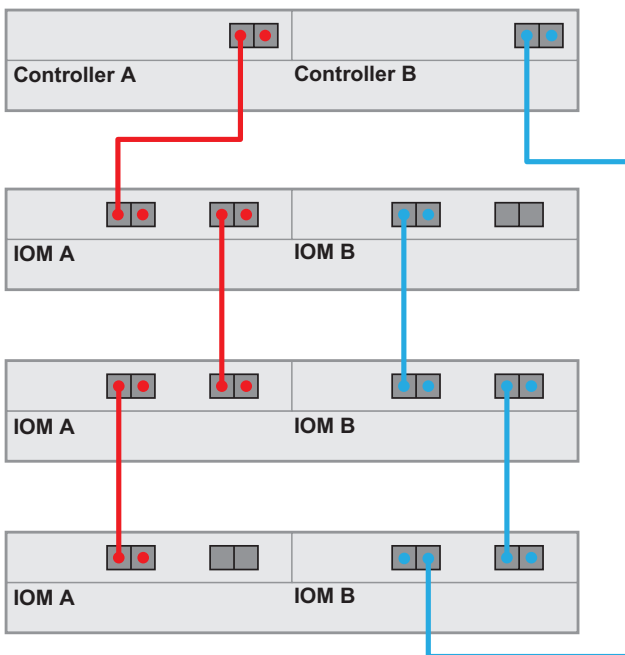

Maximum number of expansion units - dual controller configuration

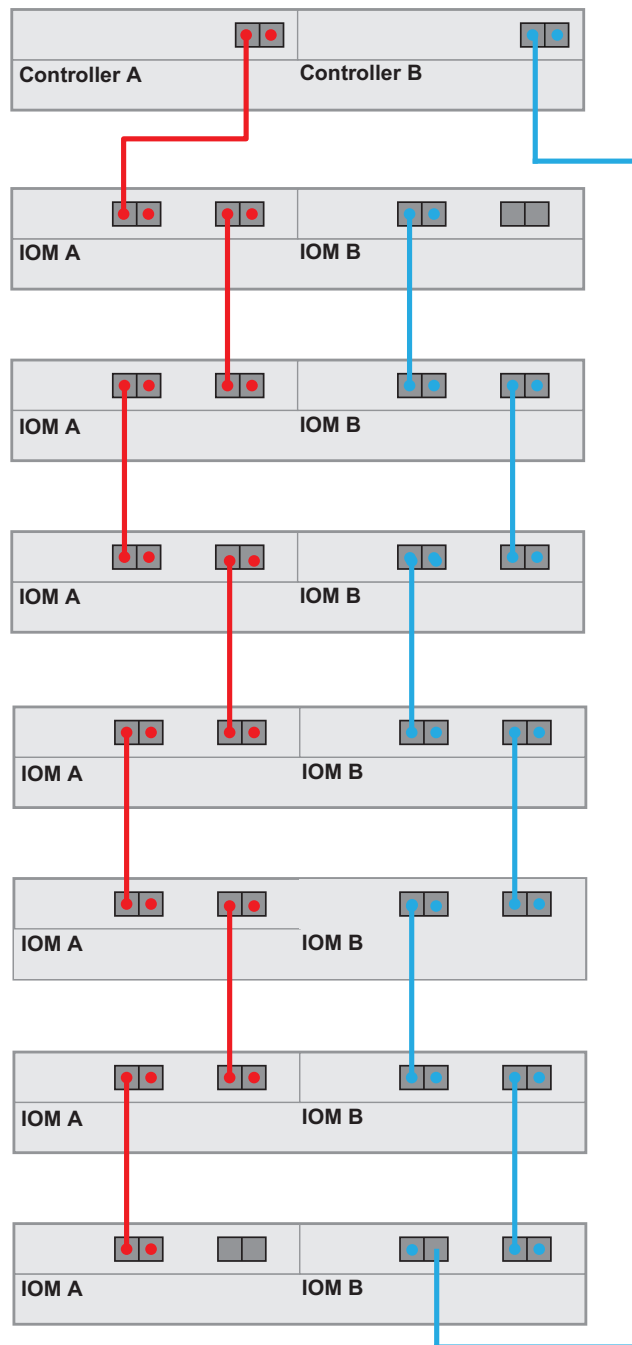

5.2

Connecting the controller unit to the network

In case of a Bosch Video Recording Solution a host is an IP camera. To connect the controller unit to the Ethernet one or two of two available iSCSI host ports must be connected to the Ethernet. The iSCSI port connections will then be used by the IP cameras for video data traffic.

To connect the controller unit to the network:

- ▶ Connect the cable from the iSCSI host port of the controller unit to a port on the switch.

Note: Make sure that the iSCSI ports of the controller unit and the relevant IP camera ports are in the same range on the switch.

Switch topology

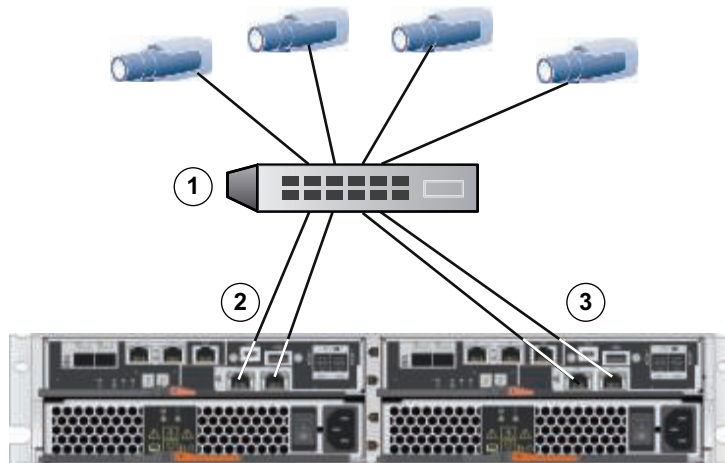

1	Switch	2	Controller A - iSCSI host interface ports (RJ45 Base-T) Note: Optionally, use the optical host interface ports.
3	Controller B - iSCSI host ports (RJ45 Base-T) Note: Optionally, use the optical host interface ports.		

5.3 Connecting the controller unit to the management hosts

The management host directly manages storage arrays over an out-of-band network. This section describes how to set up an out-of-band connection between the Ethernet port of a controller unit and the management host.

To set up an out-of-band connection:

1. Connect Ethernet cables between port 1 of controller A and port 1 of controller B to an external Ethernet switch or hub.
2. Connect the management host to the Ethernet switch or hub.

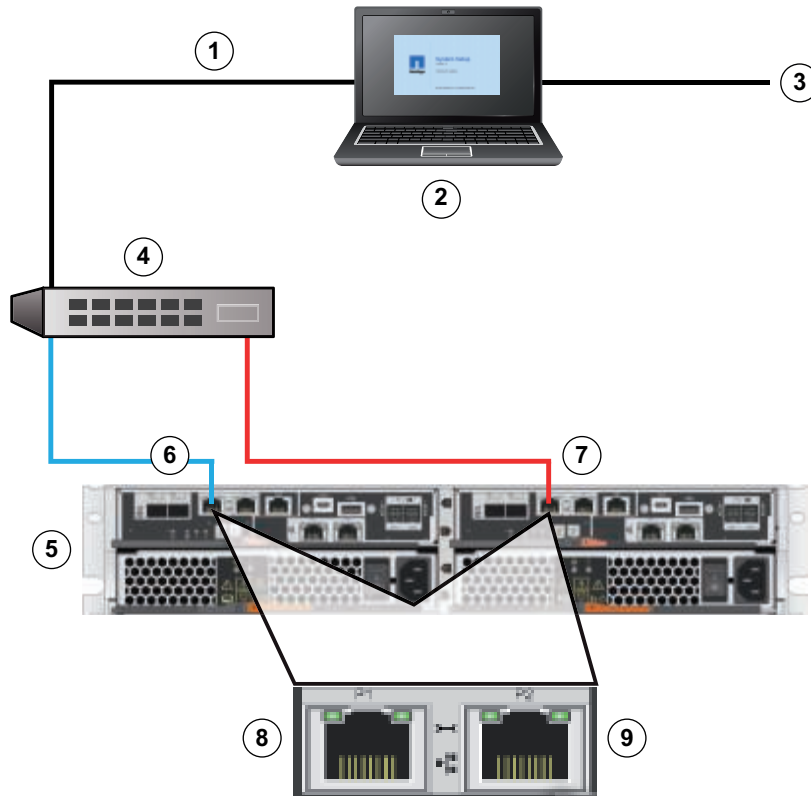

1	Private network	2	Management station or personal computer
3	Local Area Network (LAN)	4	Switch or hub
5	Dual controller unit	6	Controller A
7	Controller B	8	Management port 1 (Ethernet) Note: Used as default.
9	Management port 2 (Ethernet) Note: Reserved for maintenance operations if the hardware contains a second Ethernet port.		



Notice!

Ethernet port 2 should be reserved for maintenance operations if your hardware contains a second Ethernet port.

5.4

Connecting the units to the power supply

To connect the controller unit and the expansion units to the power supply:

1. Confirm that the two power switches on the controller unit are off.
Note: If you have expansion units, confirm that their power switches are off.

2. Connect the two power cords of the controller unit to different power distribution units in the cabinet or rack.

Note: If you have expansion units, connect the two cords accordingly.

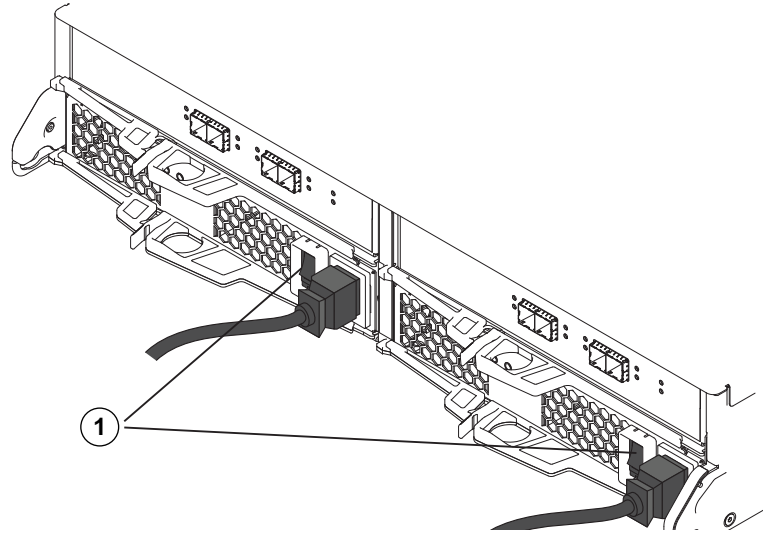

1 = Power switch

3. If you have expansion units, turn on their two power switches first.

Note: Wait for 2 minutes to allow hard disks to spin up before applying power to the controller unit.
4. Turn on the two power switches on the controller unit and wait approximately 3 minutes.

Note:

 - The default IP addresses will take approximately 3 minutes to initialize from the time the network is attached.
 - Do not turn off the power switches during the power-on process.
 - The fans are very loud when they first start up. The loud noise during start-up is normal.
5. Check the LEDs and the seven-segment display on the back of each controller.

Note: The seven-segment display shows a repeating sequence (OS, Sd, blank) to indicate that the controller is performing start-of-day processing. After the controller has started, the display shows the tray ID.
6. If any of the amber LEDs are on, there might be a problem with a component. Confirm you completed the installation steps correctly. If you are unable to resolve the problem, contact your local Bosch Technical Support team.

5.5 Supported connections

We recommend using the following connection methods:

12-bay single controller unit

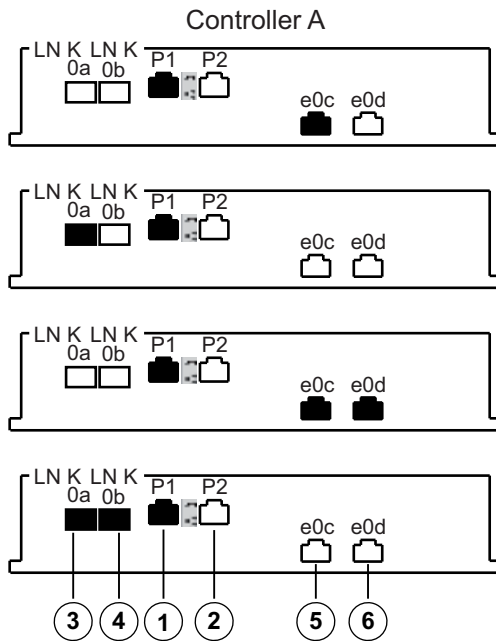

1	Management port 1 (Ethernet) Note: Used as default.	2	Management port 2 (Ethernet) Note: Reserved for maintenance operations if the hardware contains a second Ethernet port.
3	Channel 3 (iSCSI, optical)	4	Channel 4 (iSCSI, optical)
5	Channel 5 (iSCSI, RJ45 Base-T)	6	Channel 6 (iSCSI, RJ45 Base-T)

Single controller units support 2 different cabling options for the iSCSI ports.

- Default: iSCSI, RJ45 Base-T
- Alternatively: iSCSI, optical

12-bay dual controller unit

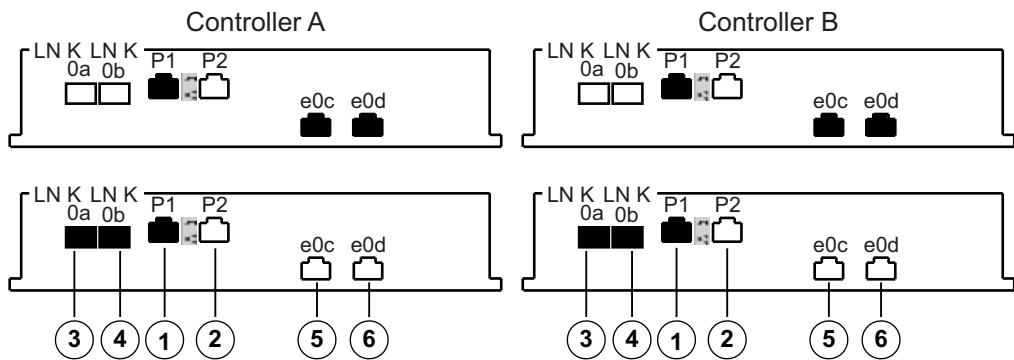

1	Management port 1 (Ethernet) Note: Used as default.	2	Management port 2 (Ethernet) Note: Reserved for maintenance operations if the hardware contains a second Ethernet port.
3	Channel 3 / Controller A and Channel 3 / Controller B (iSCSI, optical)	4	Channel 4 / Controller A and Channel 4 / Controller B (iSCSI, optical)

5	Channel 5 / Controller A and Channel 5 / Controller B (iSCSI, RJ45 Base-T)	6	Channel 6 / Controller A and Channel 6 / Controller B (iSCSI, RJ45 Base-T)
----------	---	----------	---

The Multipathing feature is enabled on dual controller units by default.

Dual controller units support 2 different cabling options for the iSCSI ports.

- Default: iSCSI, RJ45 Base-T

Note:

- Channel 5 / Controller B is the fallback of Channel 5 / Controller A and
Channel 6 / Controller A is the fallback of Channel 6 / Controller B

- Alternatively: iSCSI, optical

Note:

- Channel 3 / Controller B is the fallback of Channel 3 / Controller A and
Channel 4 / Controller A is the fallback of Channel 4 / Controller B

6 Turning on/off AC power

6.1 Turning on AC power

Make sure the Ethernet cable is connected to the management host. The default IP addresses will take three minutes to initialize from the time the network is attached.

The default IP addresses are:

- Controller A, Port 1: 192.168.128.101
- Controller B, Port 1: 192.168.128.102



Notice!

DHCP is attempted for the first three minutes of attaching the network cables. If a DHCP lease was not offered within this time, the controllers will use the default addresses.

To turn on power to the controller unit or the expansion units:

1. Connect the cabinet to the power supply.
2. Turn on the power distribution units of the cabinet.
3. If you have expansion units, turn on their two power switches first.
Note: Wait for 2 minutes to allow hard disks to spin up before applying power to the controller unit.
4. Turn on the two power switches on the controller unit and wait approximately 3 minutes.
Note:
 - The default IP addresses will take approximately 3 minutes to initialize from the time the network is attached.
 - Do not turn off the power switches during the power-on process.
 - The fans are very loud when they first start up. The loud noise during start-up is normal.
5. Check the LEDs and the seven-segment display on the back of each controller.
Note: The seven-segment display shows a repeating sequence (OS, Sd, blank) to indicate that the controller is performing start-of-day processing. After the controller has started, the display shows the tray ID.
6. If any of the amber LEDs are on, there might be a problem with a component. Confirm you completed the installation steps correctly. If you are unable to resolve the problem, contact your local Bosch Technical Support team.
7. Connect all cables if required.
8. Start recording of the cameras.

6.2 Turning off AC power

We recommend turning off the system when moving the system to another location and upgrading or replacing the hardware, for example.

To turn off power to the controller unit or the expansion units:

1. Stop recording of the cameras and wait for 5 minutes.
2. Ensure there are no background operations in progress.
3. Turn off the controller-unit and wait that all LEDs are off.
4. Turn off the expansion units and wait for 2 minutes to allow hard disks to spin down.
5. Disconnect the cables if required.

7 Configuring the storage system

This chapter describes the basic configuration of the storage system using the Configuration Manager program.

To get a basic configuration, do the following steps:

1. Start the Configuration Manager program.
2. Add the device to the system.
3. Create a basic configuration.

Starting the Configuration Manager program

To start the Configuration Manager program:

- ▶ Double-click the the Configuration Manager icon on the desktop.

Adding the device to the system

To add iSCSI devices to the system:

1. On the navigation bar, click the **Network Scan**  tab.
Note: The Configuration Manager program scans the network for compatible devices and displays the decoder in the tree structure.
2. In the tree structure, right-click a device, then click **Add to System...**
The **Add Device to System** dialog box appears.
3. Enter the name of the group or select the name from the list if you want to assign the device to a group.
Note: You can also continue without selecting or creating a group.
4. Click **OK**.
The device is added to the system.

5. Click the **My Devices**  tab to display the device in the tree structure.

Creating a basic configuration

To create a basic configuration:

1. On the navigation bar, click the **My Devices**  tab.
2. In the tree structure, click the corresponding device, click **Pool x**, click **Storage Systems**, then click the storage system.
3. In the view pane, click the **Basic configuration** tab. The basic configuration settings of the storage system appear.
4. Enter the basic settings of your storage system.
5. Click **Initialize**. An information message box appears.
6. Click **Yes** to confirm that you want to go on with the basic configuration. The **Basic Configuration for the iSCSI system** dialog box appears.
Note: The dialog box shows the status of the configuration process.
7. Click the **Status** tab to display the status of the configuration process.
Click the **Details** tab to display details about all processes.
Click **Close** to close the dialog box.

8. Click the **Reload**  icon.
9. In the tree structure, right-click the storage system, then click **LUN Assignment...** The **LUN Assignment** dialog box appears.
Note: If multiple iSCSI ports are used, distribute the LUNs equally among the logical iSCSI targets. Do not assign one LUN to multiple logical iSCSI targets.

10. Drag the **Target x** folder from the left side (**Source**) to the right side (**VRM System**), then click **OK**.
11. In the device tree, below the storage system, click **Target x**.
In the **LUNs** pane to the right, all assigned LUNs appear with the status **Unformatted**.
12. In the **LUNs** pane, click **Select All**, then click **Set**. The LUNs appear with the status **Task format** and a warning message box appears that informs you that formatting a disk will delete all data.
13. Click **Yes** to confirm. The status of the LUNs changes to **Ready**. The LUNs are formatted.

8 Maintenance

8.1 Replacing a drive in a 12-bay unit

The Recovery Guru in SANtricity System Manager monitors the drives in the unit and can notify you of an impending drive failure or an actual drive failure. When a drive has failed, its amber Attention LED is on. You can hot-swap a failed drive while the unit is receiving I/O operations.

Before you begin

- You have a replacement drive that is supported by Bosch for the controller unit or expansion unit.
- You have an ESD wristband, or you have taken other antistatic precautions.

About this procedure

Use this procedure to replace a drive in the following controller units or expansion units:

Type	Number of drives	Type of drives
12-bay controller unit	12	3.5-inch SAS drives (or 2.5-inch SAS drives in carriers)
12-bay expansion unit	12	

Drive numbering in a 12-bay controller unit or a 12-bay expansion unit



Rules for handling drives

The drives are fragile. Improper drive handling is a leading cause of drive failure. Follow these rules to avoid damaging the drives in your unit:

- Prevent electrostatic discharge (ESD)
 - Keep the drive in the ESD bag until you are ready to install it.
 - Do not insert a metal tool or knife into the ESD bag. Open the ESD bag by hand or cut the top off with a pair of scissors.
 - Keep the ESD bag and any packing materials in case you must return a drive later.
 - Always wear an ESD wrist strap grounded to an unpainted surface on your storage enclosure chassis. If a wrist strap is unavailable, touch an unpainted surface on your storage enclosure chassis before handling the drive.
- Handle drives carefully
 - Always use two hands when removing, installing, or carrying a drive.
 - Never force a drive into a unit. Use gentle, firm pressure to completely engage the drive latch.
 - Place drives on cushioned surfaces, and never stack drives on top of each other.
 - Do not bump drives against other surfaces.
 - Before removing a drive, unlatch the handle and wait 30 seconds for the drive to spin down.
 - Always use approved packaging when shipping drives.
- Avoid magnetic fields
 - Keep drives away from magnetic devices. Magnetic fields can destroy all data on the drive and cause irreparable damage to the drive circuitry.

To replace a drive observe the instructions in the following chapters:

1. *Preparing to replace a drive, page 36*

2. *Removing a drive, page 36*
3. *Installing a drive, page 37*
4. *After replacing a drive, page 37*

8.1.1

Preparing to replace a drive

Before replacing a drive, check the Recovery Guru in SANtricity System Manager and complete any prerequisite steps. Then, you can locate the failed drive.

To locate the failed drive:

1. If the Recovery Guru in SANtricity System Manager has notified you of an impending drive failure, but the drive has not yet failed, follow the instructions in the Recovery Guru to fail the drive.
2. If needed, use SANtricity System Manager to confirm you have a suitable replacement drive.
 - Select **Hardware**.
 - Select the failed drive on the unit graphic.
 - Click the drive to display the context menu, then select **View settings**.
 - Confirm that the replacement drive has a capacity equal to or greater than the drive you are replacing and that it has the features you expect.
For example, do not attempt to replace a hard disk drive (HDD) with a solid-state disk (SSD). Similarly, if you are replacing a secure-capable drive, make sure the replacement drive is also secure-capable.
3. If needed, use SANtricity System Manager to locate the drive within the storage unit.
 - If the unit has a bezel, remove it so you can see the LEDs.
 - From the drive's context menu, select **Turn on locator light**.

The drive's amber Attention LED blinks so you can identify which drive to replace.



1	Activity LED	2	Attention LED
----------	--------------	----------	---------------

8.1.2

Removing a drive

When removing a drive from a 12-bay controller unit or a 12-bay expansion unit, you must slide the drive partly out of the unit and wait for the drive to spin down. Then, you can remove the drive completely.

Before you begin:

- You have an ESD wristband, or you have taken other antistatic precautions.
- You have reviewed the *Rules for handling drives, page 35*.

To remove a drive:

1. Unpack the replacement drive, and set it on a flat, static-free surface near the unit. Save all packing materials for the next time you need to send a drive back.
2. Press the release button on the failed drive. The release button is located at the left of the drive.

The cam handle on the drive springs open partially, and the drive releases from the midplane.

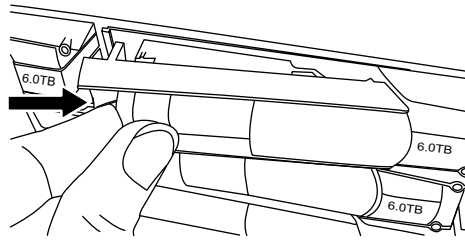

3. Open the cam handle, and slide out the drive slightly.
4. Wait 30 seconds.
5. Using both hands, remove the drive from the unit.
6. Place the drive on an antistatic, cushioned surface away from magnetic fields.
7. Wait 30 seconds for the software to recognize that the drive has been removed.



Notice!

If you accidentally remove an active drive, wait at least 30 seconds, and then reinstall it. For the recovery procedure, refer to the storage management software.

8.1.3

Installing a drive

Install the replacement drive as soon as possible after removing the failed drive. Otherwise, there is a risk that the equipment might overheat.

To install a drive:

1. Open the cam handle.
2. Using two hands, insert the replacement drive into the open bay, firmly pushing until the drive stops.
3. Slowly close the cam handle until the drive is fully seated in the midplane and the handle clicks into place.

Note: Depending on your configuration, the controller might automatically reconstruct data to the new drive. If the unit uses hot spare drives, the controller might need to perform a complete reconstruction on the hot spare before it can copy the data to the replaced drive. This reconstruction process increases the time that is required to complete this procedure.

8.1.4

After replacing a drive

After replacing a drive, you must confirm that the new drive is working correctly.

To confirm that the drive is working correctly:

1. Check the Power LED and the Attention LED on the drive you replaced.

LED status	Description
The Power LED is on or blinking, and the Attention LED is off.	The new drive is working correctly
The Power LED is off.	The drive might not be installed correctly. Remove the drive, wait 30 seconds, and then reinstall it.
The Attention LED is on.	The new drive might be defective. Replace it with another new drive. Note: When you first insert a drive, its Attention LED might be on. However, the LED should go off within a minute.

2. If the Recovery Guru in SANtricity System Manager still shows an issue, select **Recheck** to ensure the problem has been resolved.
3. If the Recovery Guru indicates that drive reconstruction did not start automatically, start reconstruction manually, as follows:

Note: Perform this operation only when instructed to do so by technical support or the Recovery Guru.

- Select **Hardware**.
- Click the drive that you replaced.
- From the drive's context menu, select **Reconstruct**.
- Confirm that you want to perform this operation.

When the drive reconstruction completes, the volume group is in an optimal state.

4. As required, reinstall the bezel on the front of the unit.
5. Return the failed part to Bosch, as described in the RMA instructions shipped with the kit.

8.2 Replacing a power-fan canister

Each 12-bay controller unit or 12-bay expansion unit includes 2 power supplies with integrated fans. These are referred to as power-fan canisters in SANtricity System Manager. If a power-fan canister fails, you must replace it as soon as possible to ensure that the unit has a redundant power source and adequate cooling.

Before you begin

- You have a replacement power-fan canister (power supply) that is supported for your 12-bay controller unit or 12-bay expansion unit.
- You have an ESD wristband, or you have taken other antistatic precautions.

About this procedure

Use this procedure to replace a power-fan canister in the following shelves:

- 12-bay controller unit
- 12-bay expansion unit

12-bay dual controller unit - rear view

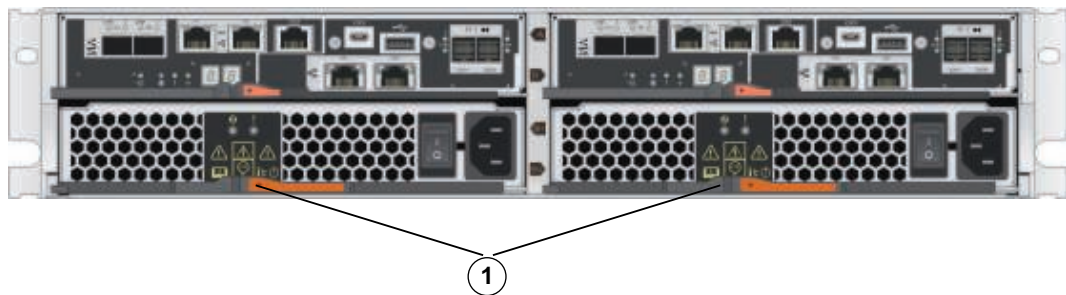

1	Power-fan canisters
----------	---------------------

12-bay expansion unit - rear view

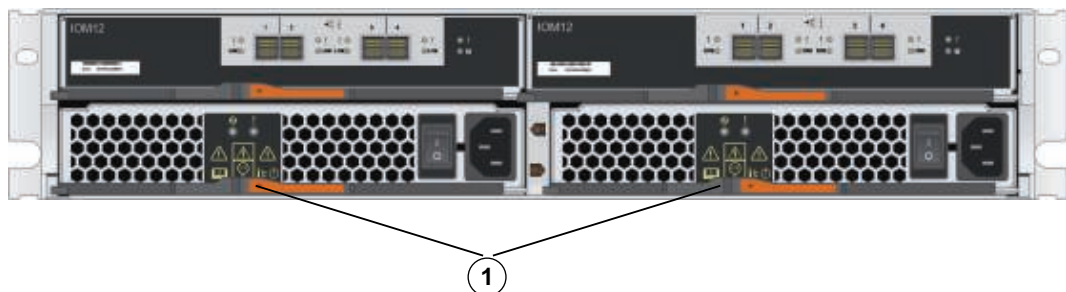

1	Power-fan canisters
----------	---------------------

You can replace a power-fan canister while the unit is turned on and performing host I/O operations, as long as the following conditions are true:

- The second power-fan canister in the unit has an Optimal status.
- The **OK to remove** field in the Details area of the Recovery Guru in SANtricity System Manager displays **Yes**, indicating that it is safe to remove this component.

Note: If the second power-fan canister in the shelf does not have Optimal status or if the Recovery Guru indicates that it is not OK to remove the power-fan canister, contact technical support.

To replace a power-fan canister observe the instructions in the following chapters:

Preparing to remove a power-fan canister, page 39

Removing a power-fan canister, page 40

Installing a power-fan canister, page 41

After replacing a power-fan canister, page 41

8.2.1

Preparing to remove a power-fan canister

Before removing a power-fan canister, use SANtricity System Manager to collect support data about your storage system and to locate the failed component.

You can determine if you have a failed power-fan canister in these ways:

- The Recovery Guru in SANtricity System Manager directs you to replace a failed power-fan canister.

Note: Before replacing a power-fan canister, select **Recheck** from the Recovery Guru to ensure no other items must be addressed first.

- The amber Attention LED on the power-fan canister is on, indicating that the power supply or its integrated fan is faulty.

Note: If both power-fan canisters in the unit have their Attention LEDs on, contact technical support for assistance.



To prepare the removing of the component:

1. Collect support data for your storage system (see *Collecting support data for the storage system, page 46*).

Note: Collecting support data before and after replacing a component ensures you can send a full set of logs to technical support in case the replacement does not resolve the problem.

2. From SANtricity System Manager, determine which power-fan canister has failed. You can find this information in the Details area of the Recovery Guru, or you can review the information displayed for the shelf.

- Select **Hardware**.

- Look at the power icon  and fan icon  to the right of the Shelf drop-down lists to determine which shelf has the failed power-fan canister.

If a component has failed, either or both of these icons will be red.

- When you find the shelf with a red icon, select **Show back of shelf**.
- Select the power-fan canister.

- On the **Power Supplies** and **Fans** tabs, look at the statuses of the power-fan canisters, the power supplies, and the fans to determine which power-fan canister must be replaced.

A component with a **Failed** status must be replaced.

Note: If the second power-fan canister in the shelf does not have **Optimal** status, do not attempt to hot-swap the failed power-fan canister. Instead, contact technical support for assistance.

- From the back of the storage array, look at the Attention LEDs to locate the power-fan canister you need to remove. You must replace the power-fan canister that has its Attention LED on.



Refer to

- *LEDs on the power-fan canister, page 17*

8.2.2

Removing a power-fan canister

When you remove a power supply (referred to in SANtricity System Manager as a power-fan canister), you turn off power, disconnect the power cord, and slide the part out of the shelf.

To remove a power-fan canister:

- Put on antistatic protection.
- Unpack the new power supply, and set it on a level surface near the drive shelf. Save all packing materials for use when returning the failed power supply.
- Turn off the power supply and disconnect the power cables:
 - Turn off the power switch on the power supply.
 - Open the power cord retainer, and then unplug the power cord from the power supply.
 - Unplug the power cord from the power source.
- Squeeze the latch on the power supply cam handle, and then open the cam handle to fully release the power supply from the midplane.

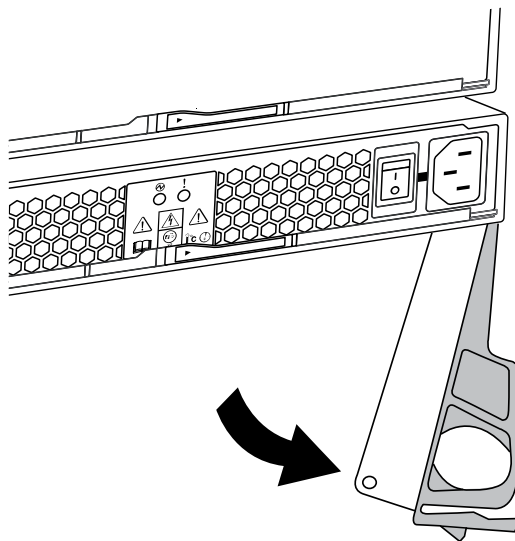

- Use the cam handle to slide the power supply out of the system. As you remove the power supply, a flap swings into place to block the empty bay, helping to maintain air flow and cooling.

Note: When removing a power supply, always use two hands to support its weight.

8.2.3 Installing a power-fan canister

To install a power-fan canister:

1. Make sure that the on/off switch of the new power supply is in the Off position.
2. Using both hands, support and align the edges of the power supply with the opening in the system chassis, and then gently push the power supply into the chassis using the cam handle.

The power supplies are keyed and can only be installed one way.

Note: Do not use excessive force when sliding the power supply into the system; you can damage the connector.

3. Close the cam handle so that the latch clicks into the locked position and the power supply is fully seated.
4. Reconnect the power supply cabling as follows:
Reconnect the power cord to the power supply and the power source.
Secure the power cord to the power supply using the power cord retainer.
5. Turn on the power to the new power-fan canister.

8.2.4 After replacing a power-fan canister

After replacing a power-fan canister, you must confirm that the new power-fan canister is working correctly. Then, you can gather support data and resume operations.

To confirm that the power-fan canister is working correctly:

1. Check the green Power LED and the amber Attention LED on the new power-fan canister. The green LED should be on and the amber LED should be off (see *LEDs on the power-fan canister, page 17*).



2. From the Recovery Guru in SANtricity System Manager, select **Recheck** to ensure the problem has been resolved.
3. If a failed power-fan canister is still being reported, repeat the steps in the following sections:
 - *Removing a power-fan canister, page 40*
 - *Installing a power-fan canister, page 41*
 If the problem continues to persist, contact technical support.
4. Remove the antistatic protection.
5. Collect support data for your storage system (see *Collecting support data for the storage system, page 46*).

Note: Collecting support data before and after replacing a component ensures you can send a full set of logs to technical support in case the replacement does not resolve the problem.

8.3 Seven-segment display codes

The following chapters explain the codes that are displayed on the seven-segment-display.

- *Seven-segment display sequence codes, page 42*
- *Seven-segment display codes when controller turns on, page 43*
- *Seven-segment display use cases, page 43*
- *Seven-segment display lock-down codes, page 44*

8.3.1 Seven-segment display sequence codes

Seven-segment display sequences enable you to understand errors and operational states of the various components in your storage array. Each sequence shows a two-digit category code, followed by a two-digit detail code. The category code appears at the start of a sequence and the detail code follows the category code with more specific information about the error. After each category code is displayed, the LED goes blank. Then the detail code appears and disappears, and the entire sequence is repeated. For example, if there is a power-on validation error during startup, you see the following codes displayed on the seven-segment display: SE, followed by Sx, in which SE is the category code and Sx is the detail code.

When the seven-segment display sequence starts, the Diagnostic LED is on (green).

The following table includes the seven-segment display sequence codes and descriptions:

Category	Category code	Detail code
Startup error	SE	<ul style="list-style-type: none"> – 88: Power-on default – dF: Power-on diagnostic fault – Sx: Power-on validation error
Operational error	OE	<ul style="list-style-type: none"> – Lx: Lock-down codes See Seven-segment display lock-down codes.
Operational state	OS	<ul style="list-style-type: none"> – OL: Offline – bb: Battery backup (operating on batteries) – OH: CPU temperature exceeds the warning level – CF: Component failure
Component failure	CF	<ul style="list-style-type: none"> – dx: Processor or cache DIMM – Cx: Cache DIMM – Px: Processor DIMM – Hx: Host interface card – Fx: Flash drive – bl: Base controller card
Diagnostic failure	dE	<ul style="list-style-type: none"> – Lx: Lock-down codes See Seven-segment display lock-down codes.
Category delimiter	--	
	Note: The double hyphen (--) is the separator between categorydetail code pairs when more than one pair exists in the sequence.	
End-of-sequence delimiter	Blank: The display turns off at the end of a sequence.	

8.3.2 Seven-segment display codes when controller turns on

The following table describes the seven-segment codes that are displayed when the controller turns on:

Code	Description
0xEA	DDR4 training failed
0xE8	No memory installed
0x22	No master boot record found on any boot device
0x23	No SATA drive installed
0xAE	Booting OS
0xAB	Alternate boot code
0x40	Invalid DIMMs
0x41	Invalid DIMMs
0x42	Memory test failed
0x2A, 0x2B	Stuck bus, unable to read DIMM SPD data
0x51	DIMM SPD read failure
0xA0, 0xA1, 0xA2, and 0xA3	SATA drive initialization
0x92 - 0x96	PCI bus initialization

8.3.3 Seven-segment display use cases

The following table shows seven-segment display use cases and the sequence that is displayed in each case:

Use case	Display sequence
Controller power-on	
– Normal power-on controller insertion	SE 88 blank
– Controller inserted while held in reset	
Operational states	
Normal operation	xy (static controller tray ID)
Start-of-day (SOD) processing	OS Sd blank
The controller is placed in reset while showing the tray ID	OS OL blank
The controller is operating on batteries (cache backup)	OS bb blank
The CPU temperature has exceeded the warning level	OS OH blank
Component failure when the controller is operational	
Failed host interface card (HIC)	OS CF HX blank

Use case	Display sequence
Failed flash drive	OS CF Fx blank
Power-on diagnostic failure	
Failure of a component that is not a field replaceable unit	SE dF blank-
Processor DIMM failure	SE dF -- CF Px blank-
Cache memory DIMM failure	SE dF -- CF Cx blank-
Processor DIMM or cache memory DIMM failure	SE dF -- CF dx blank-
Host interface card failure	SE dF -- CF Hx blank-
Incorrect number of cache backup devices	SE LC -- CF Fx blank-
The controller is suspended and there are no other errors to report	
All lock-down conditions	OH Lx blank
The controller is suspended because of component errors	
Persistent processor DIMM error correcting code (ECC) errors	OE L2 -- CF Px blank-
Persistent cache DIMM ECC errors	OE L2 -- CF Cx blank-
Persistent processor or cache DIMM ECC errors	OE L2 -- CF dx blank-
The controller is suspended as a result of persistent cache backup configuration errors	
The write-protect switch is set during cache restore	OE LC blank-
The memory size changed with dirty data in the flash drives	OE L2 -- CF dx blank-
The controller is suspended as a result of diagnostic errors	
Cache memory diagnostic failure	dE L2 -- CF Cx blank-
Base controller diagnostic failure	dE L3 -- CF b1 blank-
Base controller I/O Controller chip (IOC) diagnostic failure	dE L3 -- CF b2 blank-

8.3.4

Seven-segment display lock-down codes

Diagnostic lock-down codes are displayed when the controller is not operational, either because of a configuration problem or a hardware fault. The lock-down code is displayed as part of the seven-segment display sequence.

The following table includes the lock-down codes and describes the conditions that cause the controller to be in a suspended state:

Lock-down code	Description
L0	The controller types in a duplex configuration are mismatched.

Lock-down code	Description
L1	Missing interconnect canister.
L2	A persistent memory error has occurred.
L3	A persistent hardware error has occurred.
L4	A persistent data protection error has occurred.
L5	An auto-code synchronization (ACS) failure has been detected.
L6	An unsupported HIC has been detected.
L7	A sub-model identifier either has not been set or has been mismatched.
L8	A memory configuration error has occurred.
L9	A link speed mismatch condition has been detected in either the I/O module (IOM) or the power supply.
Lb	A HIC configuration error has been detected.
LC	A persistent cache backup configuration error has been detected.
Ld	A mixed cache memory DIMMs condition has been detected.
LE	Uncertified cache memory DIMM sizes have been detected.
LF	The controller has locked down in a suspended state with limited SYMbol support.
LH	A controller firmware mismatch has been detected.
LJ	The controller does not have enough memory to support the configuration.
LL	The controller cannot access either midplane SBB EEPROM.
Ln	A module is not valid for a controller.
LP	Drive port mapping tables are not detected.
Lr	A component that is not a field replaceable unit (FRU) has been replaced.
Lt	A configuration data base corruption has been detected.
LU	The SOD reboot limit has been exceeded.

In some cases, controllers detect errors during the startup process.

The following table describes seven-segment startup errors and conditions that result in the controller being in a suspended state:

Startup error code	Description
S1	The controller detects a checksum failure in EEPROM.
S2	The SBB Signature/Revision is invalid.
S3	An unsupported enclosure is detected in the storage array.
S4	The power supplies are incapable of powering the controller.
S5	The SBB pairing has failed.

8.4 Collecting support data for the storage system

The following procedures describe how to collect support data for the storage system using SANtricity System Manager and Script editor in the Enterprise Management Window (EMW).

Collecting support data using SANtricity System Manager

1. Select **Support > Support Center > Diagnostics**.
2. Select **Collect Support Data**.
3. Click **Collect**.
The file is saved in the Downloads folder for your browser with the name `supportdata.7z`

Collecting support data using Script editor in the EMW

1. Open the Enterprise Management Window (EMW) in SANtricity Storage Manager on your local host.
2. Select the storage system.
3. Select **Tools > Execute Script**.
4. Type the following command in the text box.
`save storageArray supportData file="filename";`
In this command, `filename` is the file path and the file name to which you want to save the support data. Enclose the file path and the file name in double quotation marks (" ").
For example:
`file="C:\Program Files\CLI\logs\support-data.7z"`
5. Select **Tools > Verify and Execute**

9 Support services and Bosch Academy



Support

Access our **support services** at www.boschsecurity.com/xc/en/support/.

Bosch Security and Safety Systems offers support in these areas:

- [Apps & Tools](#)
- [Building Information Modeling](#)
- [Warranty](#)
- [Troubleshooting](#)
- [Repair & Exchange](#)
- [Product Security](#)



Bosch Building Technologies Academy

Visit the Bosch Building Technologies Academy website and have access to **training courses**, **video tutorials** and **documents**: www.boschsecurity.com/xc/en/support/training/



Bosch Security Systems B.V.

Torenallee 49
5617 BA Eindhoven
Netherlands

www.boschsecurity.com

© Bosch Security Systems B.V., 2021