

MIC-7604-Z12WR PTZ 8MP 12x enhanced white

MIC inteox 7100i



- ▶ UHD “4K” resolution (3840 x 2160 pixels) @ 30fps, 12x zoom with Optical Image Stabilization (OIS)
- ▶ Exceptional strength and ruggedness for any outdoor application including traffic monitoring (bridges, tunnels, or highways), perimeter protection, city surveillance, and mining
- ▶ Built-in Camera Trainer to train the camera to recognize user-specified target objects, such as moving and non-moving objects, to alert operators of unusual scene activity
- ▶ Edge intelligence with Intelligent Tracking and object detection even when the camera is moving
- ▶ Optional illuminator with multispectral LEDs that distribute IR light uniformly in the field to avoid dark spots or an over-illuminated scene

The MIC inteox 7100i camera is an advanced PTZ surveillance platform “driven by OSSA,” ensuring seamless connectivity with the Azena Application Store to add easily third-party software apps that meet customer-specific requirements.

With starlight imaging technology and excellent low-light sensitivity, the camera is the perfect solution for robust and high-quality imaging needs for mission-critical applications.

The camera’s ruggedized design meets customer expectations in demanding environments that exceed the capabilities of conventional IP cameras. Even in installations subject to harsh shock/vibration conditions and/or extreme weather, the camera provides high-quality video images.

The camera is the ideal choice for:

- Transportation: highways, bridges/tunnels, and ports
- Critical infrastructure: power generation/transmission, refineries/pipelines, and mining
- High-security: government facilities and data centers
- Mission-critical applications involving harsh environments that require high-resolution imaging

- Complex scenes with many details under any lighting condition
- Installations where downtime is undesired because of high service costs

Intelligent open, flexible, and extendable camera platform

The camera has a powerful, embedded processor with dedicated hardware to support advanced machine learning and neural-network-based Video Analytics. All cameras with this platform have high image quality, built-in Video Analytics, intelligent bitrate management, and the highest levels of data security. The platform also gives you the flexibility to customize your camera to your specific requirements.

The camera platform integrates with the cloud infrastructure of Azena for app management across devices. Also, Bosch offers advanced device management and services through the Bosch Remote Portal (<https://remote.boschsecurity.com/>). From the Bosch Remote Portal you can (remotely):

- Complete initial configuration of your online and connected Bosch devices.
- Update firmware for single or multiple devices.

- Manage certificates through Configuration Manager or the web interface of your camera.
- Monitor the health of and receive alerts for your connected Bosch devices.
- Connect your Bosch devices to the Azena portal for app management.

Functions

Ruggedized design for extreme applications

The camera is designed to last in surveillance applications that are beyond the mechanical capabilities of conventional positioning systems. The entire metal body is anodized and has been engineered to withstand high-impact, low-frequency vibration. The camera models comply to IK10 rating for impact resistance and to the IEC 60068 standards applicable to vibration and shock.

The camera has a closed-loop positioning system. The system allows the camera to maintain its position under continuous vibration or after an extreme shock event, even without homing or pre-position calibration.

The camera benefits from Bosch domain knowledge in material engineering and coatings. As a result, the superior metallurgy and the finish of the camera provide unprecedented protection against corrosion. The camera has been tested to and meets the ISO 12944:6 standard C5-M - very high (marine) on Aluminum Housing Components.

Defroster on the viewing window

For installations in environments where ice build-up or condensation is a possibility, the camera has an automatic defrosting function. The inside of the camera window has a transparent coating that puts heat directly on the glass. The heat on the glass helps to decrease and to prevent a build-up of ice as well as condensation on the camera window.

Based on the same technology used to de-ice aircraft windscreens, the defroster can melt 1 cm (0.4 in.) of accumulated ice in five minutes in environments as cold as -25 °C (-13 °F). The defroster starts automatically at ≤ 5 °C (41 °F). Even in very cold environments, where other cameras suffer from frosted windows, the enhanced MIC models let you see more and see better.

Both the defroster and the IP67 kit, correctly installed on the connectors in the camera base, help to decrease condensation on the camera window.

Robust design rated to an industry-leading IP68, Type 6P, IK10

Subjected and certified to rigorous dust and immersion tests (IP68, Type 6P) and impact test (IK10), MIC cameras are perfectly suited for installation in even the most unforgiving environments. Anodized aluminum housing and robust, powder coat paint give unequalled corrosion protection to each MIC camera. Reliable O-ring seals completely protect the internal components from the external environment, meaning that there is no need

to pressurize the camera. To guarantee unit integrity, the factory tests each MIC camera for leaks before shipping.

Pan and tilt drive mechanism

The pan and tilt mechanisms use ruggedized, all-metal intermeshing gears, which are more resistant to shock and to vibration. Cameras with all-metal gears have a longer operational life than cameras with plastic gears and drive belt systems of rubber. High-efficiency motors with brushless positioning control the pan and tilt movement directly to support continuous operation without significant wear and tear. Innovative dual spring-loaded gears on the pan and tilt stage reduce backlash and further improve positional accuracy. The spring-loaded gears provide a more stable image compared to belt-driven cameras.

Dual-mode illumination

The MIC illuminator accessory (sold separately) has IR LEDs and White light LEDs. The illuminator is field-installable.

Note: The cameras in this product family are compatible with MIC-ILx-400 models only. The distances and the performance depend on the environmental light conditions.

The following table identifies the application for each type of LED.

Application	Type of illuminator
Close-range illumination	940 nm IR LEDs
Long-range detection	850 nm IR LEDs
Identification and deterrent	White light LEDs

The MIC camera can steer the IR beam dynamically to match the illumination intensity with the camera's field of view according to the zoom level.

Beam intensity is controlled automatically or manually, depending on user preference. Decreasing intensity reduces overexposure.

The patented, integrated Constant Light technology supplies a consistent level of illumination during the life of the product, even in changing temperatures. White light mode allows operators to capture full scene details in color or use the light as a deterrent effect.

H.265 high-efficiency video encoding

The camera is designed on the most efficient and powerful H.264 and H.265/HEVC encoding platform. The camera is capable of delivering high-quality and high-resolution video with very low network load. With a doubling of encoding efficiency, H.265 is the compression standard of choice for IP video surveillance systems.

More flexibility in streaming capabilities

The camera has three independent encoder streams. Users can configure each stream individually to change the video resolution and the frame rate. Users have two options:

1. Let the camera deliver what is possible based on its encoding performance across the streams equally.
2. Select one of the three streams to be prioritized, for example, to guarantee “quality of service” for the recording stream.

Users can select the coding standard (H.264/H.265) for each stream.

Each stream also has its own set of 8 encoder profiles that users can configure.

Recording and storage management

Control recording management with the Bosch Video Recording Manager application.

Intelligent Video Analytics on the edge

The camera includes the latest release of Intelligent Video Analytics application for use on pre-positions.

Designed for mission-critical applications, the video analytics can reliably detect, track, and analyze moving objects while suppressing unwanted alarms from spurious sources in the image, even in harsh weather conditions.

Advanced tasks like multiple line crossing, loitering, idle / removed object detection, crowd density estimation, occupancy and people counting are available for live alarming and forensic search. Object filters based on size, speed, direction, aspect ratio, and color can be defined.

A simplified calibration mode reduces installation time significantly, because you only need to enter the installation height once for each camera, independent of pre-positions.

After the camera is calibrated, the analytics engine can automatically classify objects as upright person, car, bike, or truck.

Support for specific use cases

Intelligent Video Analytics 8.10 offers easy setup by providing optimal default values for several applications. Calibrate the camera, then simply select the desired use case and adapt the offered alarm fields and lines to your field of view. This is available for the following scenarios:

- Intrusion detection (smaller area, single alarm field)
- Intrusion detection (long distance, 2 alarm fields must trigger)
- People counting
- Traffic monitoring (automatic incident detection with wrong way detection, pedestrian detection, slow vehicles, stopped vehicles and dropped objects)
- Traffic monitoring (wrong way detection)

With a future-proof design, the camera can tackle new use cases by delivering more reliable detections, more detailed classifications, and thus more insights on what is happening in a scene. Based on the open platform principle, these capabilities are leveraged by Intelligent Video Analytics by Bosch as well as by third-party apps from the Application store from Azena.

Video Analytics while camera is moving

Outside of pre-positions and even while the PTZ camera is moving, whether on guard tours or manually, the Intelligent Video Analytics application can detect and start alarms when objects are in alarm fields. These alarm fields are defined once across all PTZ camera views. The camera can automatically trigger an alarm if any part of a field within the camera's view becomes active while on a guard tour sweeping across the monitored areas.

Camera Trainer

Based on examples of target objects and non-target objects, the Camera Trainer program uses machine learning to allow the user to define objects of interest and generate detectors for them. In contrast to the moving objects that the Intelligent Video Analytics application detects, the Camera Trainer program detects both moving and non-moving objects and classifies them immediately. Using Configuration Manager, you can configure the Camera Trainer program using both live video as well as recordings available through the respective camera. The resulting detectors can be downloaded and uploaded for distribution to other cameras.

A free of charge license is required to activate the Camera Trainer program.

Areas with potentially interfering background motion (moving trees, pulsating lights, and busy roads) can be masked out.

Optical Image stabilization

The camera incorporates a built-in, optical image stabilization feature which prevents pixel loss and outperforms electronic image stabilization.

If it detects vibration, the camera dynamically corrects the shaky video in both the vertical and horizontal axis, resulting in exceptional image clarity and a stable field of view on the monitor.

Auto Exposure (AE) region and Focus region

With the Auto Exposure (AE) function, the camera computes the lighting condition of the entire scene. Then the camera determines the optimum level of iris, gain, and shutter speed.

In AE region mode, users can designate a specified area of the scene, based on pre-positions. The camera computes the lighting condition of the specified area. Then the camera determines the optimum level of iris, gain, and shutter speed to get an image.

Snap to zoom

Drawing a box in the image will trigger the camera to zoom to the correct position.

Simple set-up

The camera has a very intuitive user interface that allows fast and easy configuration. Configurable scene modes are provided with the best settings for a variety of applications.

- **Standard**

This mode is optimized for most standard scenes both indoor and outdoor.

- **Sensitivity boost**

This mode provides maximum sensitivity in low light scenes by using longer exposure times, resulting in bright images even in extreme low light.

- **Fast movement**

This mode is used for monitoring fast moving objects like cars in traffic scenes. Motion artifacts are minimized and the image is optimized for a sharp and detailed picture in color and monochrome.

- **Vibrant**

This mode provides a more vivid image with increased contrast, sharpness, and saturation.

- **Color Only (Traffic)**

In this mode, the camera does not switch to monochrome mode at low light levels. The mode is optimized to minimize motion artifacts and to capture the color of vehicles/pedestrians and traffic lights, even at night, for scenarios such as city surveillance and traffic monitoring.

- **Illuminator**

This mode gives optimized performance when using the MIC illuminator accessory.

Focus region mode, unlike normal auto focus mode, allows users to focus on a specified area of the scene.

Data security

Special measures are necessary to ensure the highest level of security for device access and data transport. On initial setup, the camera is only accessible over secure channels. A three-level password protection with security recommendations lets users customize device access. Unsecure ports are disabled. Firmware updates are only possible with Bosch-signed firmware files. The Embedded Login Firewall improves robustness against Denial of Service (DoS) attacks. The software sealing functionality can detect changes in a configuration. HTTPS or other secure protocols prevent access to the web browser and the viewing client. With the feature of secure and verified boot, you can trust all executed code in the device. TPM functionality is provided by “Secure Element” (dedicated AES/DES/PKI crypto co-processor) that:

- Is independently certified with Assurance Level (EAL) 6+ based on Common Criteria for Information Technology Security Evaluation [out of 7 levels according to ISO/IEC 15408]
- Has cryptography with a maximum of 4096 bit RSA keys for TLS (maximum version 1.3) and device identity (Future-proof until 2031 and beyond) [according to NIST Special Publication 800-57, part 1, page 56]

The advanced certificate handling offers:

- Self-signed, unique certificates automatically created when required
- Client and server certificates for authentication
- Client certificates for proof of authenticity
- Certificates with encrypted private keys

Only trusted and authenticated third-party apps can be uploaded. A safe sandbox environment enables the secure execution of trusted third-party software. There is full transparency on individual app requirements to access system resources (listed in the Application store from Azena).

Software sealing

After camera configuration is set and should not be changed, system administrators can enable software protection that seals the camera configuration. Any change of the sealing status and any change to static configuration, accidentally or intentional, will break the seal. The camera then sends an alarm message that the video management system can use to start an appropriate alarm scenario. The camera creates a separate log file of all changes that have an effect on the sealing status.

System integration and ONVIF conformance

The camera conforms to the specifications for ONVIF Profile S, ONVIF Profile G, and ONVIF Profile M. (ONVIF is the acronym for Open Network Video Interface Forum.) For H.265 configuration, the camera also supports Media Service 2, which is part of ONVIF Profile T. Compliance with these standards guarantees interoperability between network video products, regardless of manufacturer. Third-party integrators can easily access the internal feature set of the camera for integration into large projects. For more information, see the Bosch Integration Partner Program (IPP) website (ipp.boschsecurity.com). Cameras with this platform are intended to be backwards compatible with existing VMS integrations. Compatibility of the app feature set that is available in the Application store is the responsibility of the app developer and of Azena.

Ease of installation

The camera supports mounting in upright, inverted, or canted orientation. The on-site canting functionality lets installers tilt down the upper section of the camera at a 35° angle. At this angle, operators can see the scene directly below the camera. The camera has been designed for quick and easy installation, a key feature from Bosch IP video security products.

Power options

The camera can be powered by a network compliant to High Power-over-Ethernet using a Bosch model of High PoE Midspan (sold separately). With this configuration, only a single cable connection (Cat5e/Cat6 Shielded Twisted Pair (STP)) is needed to view, to power, and to control the camera.

For maximum reliability, the camera can operate with a redundant power system of a High PoE Midspan and a separate 24 VAC power source connected simultaneously. If either the High PoE or 24 VAC power source fails, the camera seamlessly transitions to the remaining power source.

The 60 W midspan can supply power to models without an illuminator accessory. The 95 W midspans can supply power to all models of MIC IP ultra 7100i, including models with the illuminator accessory. The camera can also accept a standard 24 VAC power source if a High PoE network interface will not be used. User-supplied wiring must be in compliance with electrical codes (Class 2 power levels).

Camera Diagnostics

The camera has several built-in sensors / advanced diagnostics that display warnings on the camera's OSD about the health of the camera. The diagnostics log records the events such as:

- Low voltage - a drop in incoming power below the level where the camera becomes non-functional
- High temperature - the internal temperature exceeds specifications
- Low temperature - the internal temperature exceeds minimum levels
- High humidity - the internal humidity exceeds 70%
- High vibration - the acceptable level of acceleration forces was exceeded
- Total hours of camera operation
- Illuminator aging history

Certain events also appear on the camera's OSD. These diagnostic records are available for the installation or service technician to review.

Unsurpassed reliability

As with all Bosch products, the camera is designed using the industry's best design process and is subjected to the most stringent testing standards such as HALT (highly accelerated life testing), which pushes the limits of products to ensure reliability throughout their lifetime.

Project Assistant

Project Assistant by Bosch is the market's most easy-to-use app for initial installation and basic configuration of IP cameras. Off-site and without connection to the camera, basic configurations can be created and then shared with colleagues. On-site, these pre-configurations can be pushed onto the camera, making the installation procedure easier and less time-consuming. Cameras previously configured can be integrated as well. The app allows easy viewing and adjustment of the camera's field of view. The app automatically generates a comprehensive report of the commissioned cameras.

Certifications and approvals

For a full list of all related certifications/standards, refer to the Product Tests Report, available on the online catalog, on the Documents tab of the product page for your device. If the document is unavailable on the product page, contact your sales representative.

Electromagnetic Compatibility (EMC)	Complies with FCC 47 CFR Part 15, ICES-003, and CE regulations, including latest versions of: EN 50130-4 EN 50121-4 (Railway applications) EN 55032 CISPR 32
Product Safety	Complies with UL, CE, CSA, EN, and IEC Standards including: UL 62368-1 UL 60950-1, Ed. 2 CAN/CSA-C22.2 No. E60950-1-07 EN 62368-1 EN 60950-1 EN 60950-22 CAN/CSA-C22.2 No. 62368-1-14 IEC 62368-1 Ed.2* IEC 60950-1 Ed.2** IEC 60950-22 Ed.2
Marks	UL, CE, WEEE, EAC, FCC, RoHS, RCM

* Except the Steady-state test (6.2.2.2) for Australia

** Except the Steady-state test (5.4.10.2.3) for Australia

Region	Regulatory compliance/quality marks	
Europe	CE	Declaration of Conformity (DoC)

Installation/configuration notes

In the table below, an "X" identifies the power source options for MIC IP camera models.

Camera models	60 W midspan	95 W midspan	24 VAC PSU*
Models with illuminator		X	X
Models without illuminator	X	X	X

* recommended: 24V at 100VA, 4A with a slow blow fuse

Mounting Bracket Options

Bosch designed MIC IP 7100i cameras for use in outdoor applications. In an enclosed installation area (for example, in a foundry, near a furnace, etc.), temperatures outside of the camera might exceed +65 °C (+149 °F). If you install a camera in an

enclosed area, make sure that the operating temperature of the camera is a maximum of +60 °C (+140 °F). Make sure that air circulates around the camera to supply cooling.

The following figure identifies the optional mounting brackets for MIC cameras. Refer to the datasheets of each bracket for details. Some brackets may not be available in all regions.

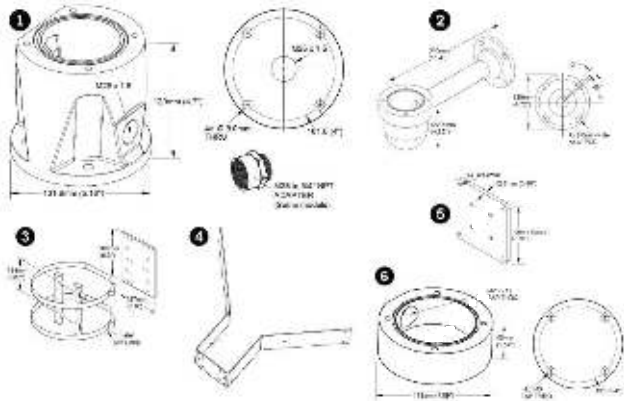

Fig. 1: Optional Mounts, MIC IP 7100i series

- 1 Deep conduit adapter
- 2 Wall mount bracket
- 3 Pole mount bracket
- 4 Corner mount bracket
- 5 Wall mount spreader plate
- 6 Shallow conduit adapter

For more options, refer to the MIC IP cameras Accessory Quick Selection Guide (https://media.boschsecurity.com/fs/media/pb/media/support_1/tools/mic_ip_cameras_accessory_quick_selection_guide.pdf).

Dimensional Drawings

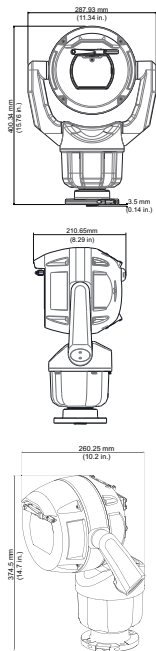

Fig. 2: Canted

Parts included

Quantity	Component
1	MIC inteox 7100i camera
1	spanner tool [to remove and to attach the yoke caps in order to cant the camera if desired, and to remove the access plug from the camera head when installing the optional illuminator accessory (sold separately)]
1	base gasket
1	RJ45 coupler
1	MAC address labels
1	Quick Installation Guide
1	Safety instructions

Technical specifications

Imager	1 in. Exmor R CMOS Sensor
Effective Picture Elements (Pixels)	5544 x 3694 (20.47 MP)
Lens	12x motorized Zoom; 9.3 mm to 111.6 mm; F2.8 to F4.5
Field of view (FOV) (with optic image stabilizer ON)	6.1° to 64.6° (6.1° to 64.5°)
Focus	Automatic with manual override, Region per pre-position
Iris	Automatic with manual override
Digital zoom	12x Note: Super resolution zoom is always on when digital zoom is <1.5X. This feature is not available at higher zoom values.

Video performance - Sensitivity

(3100K, reflectivity 89%, 1/30, F1.6, 30 IRE)

Color	0.292 lx
Monochrome	0.0110 lx

Video performance - Dynamic range

High dynamic range (measured according to IEC 62676 Part 5)	62 dB
---	-------

Firmware

Common Product Platform	CPP13
-------------------------	-------

DORI	Distance	To	Object
	WIDE 1X	TELE 12X	Scene width
Detection 25 pixels/m (8 pixels/ft)	121 m (397 ft)	1441 m (4728 ft)	154 m (505 ft)
Observation 63 pixels/m (19 pixels/ft)	48 m (157 ft)	572 m (1877 ft)	61 m (200 ft)
Recognition 125 pixels/m (38 pixels/ft)	24 m (79 ft)	288 m (945 ft)	31 m (102 ft)
Identification 250 pixels/m (76 pixels/ft)	12 m (39 ft)	144 m (472 ft)	15 m (49 ft)

Additional Camera Settings

Modes for viewing the video area of pre-position settings	Automatic exposure, either full-screen or defined to a specific area Focus
Gain control	AGC, Fixed, Region per pre-position
Aperture Correction	Horizontal and vertical
Electronic Shutter Speed (AES)	1/1 sec to 1/10000 sec (22 steps)
Signal-to-Noise Ratio (SNR)	>55 dB
Backlight compensation (BLC)	On / Off / Intelligent Auto Exposure (IAE)
White balance	2000 K to 10,000 K ATW, AWB Hold, Extended ATW, Manual, Sodium Lamp Auto, Sodium Lamp
Day/Night	Monochrome, Color, Auto
Defog mode feature	Improves visibility when viewing foggy or other low-contrast scenes.
Noise Reduction	Intelligent Dynamic Noise Reduction
Sectors	4, 6, 8, 9, 12, or 16 user-selectable, independent Sectors, each with 20 characters per Title

Privacy Masks	32 individually configurable Privacy Masks; maximum 8 per Pre-position; programmable with 3, 4 or 5 corners; select your own color from the color palette. With the "Auto" option, the camera selects the most prevalent of the three colors in the background scene as the pattern color. With the "Mosaic" option, the movements behind a Privacy Mask will remain visible.
Virtual Masks	24 individually configurable Virtual Masks to hide parts of the scene (background motion such as moving trees, pulsating lights, busy roads, etc.)
Pre-positions	256 Pre-positions, each with 20 characters per Title
Guard Tours	Custom Recorded Tours - two (2), total duration 30 minutes: Pre-position tour - one (1), consisting of up to 256 scenes consecutively, and one (1) customized with up to 256 user-defined scenes
Supported Languages	English, Czech, Dutch, French, German, Italian, Polish, Portuguese, Russian, Spanish, Japanese, Chinese
Alarm control	Rules-based logic supports basic and complex pre-defined user-specified commands In its most basic form, a "rule" could define which input(s) should activate which output(s).
Camera status monitoring	Integrated sensors monitor operational status such as internal temperature, humidity level, incoming voltage level, vibration, and shock events.
Diagnostics	Various status conditions are tracked in the internal diagnostic log. Critical fault conditions will also be displayed on screen.

Video content analysis

Analysis type	Intelligent Video Analytics
Configurations	Off / Global VCA / Profiles 1 - 16
Calibration	Automatic self-calibrating when height is set
Alarm rules (combinable)	Any object, Object in field, Crossing line, Entering field, Leaving field, Loitering, Following route, Idle object, Removed object, Counter, Occupancy, Crowd detection, Condition change, Similarity search, Tampering
Object filters	Duration, Size, Aspect ratio v/h, Speed, Direction, Object classes (Upright persons, Bikes, Cars, Trucks), Color

Network

Standard/Video compression	H.265, H.264 (ISO/IEC 14496), M-JPEG, JPEG
Streaming	3 fully configurable streams, with the option to activate or deactivate VCA overlays on each stream

Resolution (H x V)	Pixels
4K UHD	3840 x 2160
1080p HD	1920 x 1080
720p HD	1280 x 720
432p SD	768 x 432
288p SD	512 x 288

Protocols	IPv4, IPv6, UDP, TCP, HTTP, HTTPS, RTP/RTCP, IGMP V2/V3, ICMP, ICMPv6, RTSP, FTP, ARP, DHCP, APIPA (Auto-IP, link local address), NTP (SNTP), DNS, DNSv6, DDNS (DynDNS.org, selfHOST.de, noip.com), SMTP, iSCSI, UPnP (SSDP), DiffServ (QoS), LLDP, SOAP, Dropbox™, CHAP, digest authentication
-----------	---

Note: Dropbox is a trademark of Dropbox, Inc.

Ethernet	100BASE-TX/1000 Base-T, auto-sensing, half/full duplex, Auto-MDI-X
Encryption	TLS 1.0, TLS 1.1, TLS 1.2, AES128, AES256
Ethernet connector	RJ45
GOP structure	IP, IBP, IBBP
Camera internal delay	8MP models: 30 fps: 410 ms (typical) 2MP models: 30 fps: 233 ms (typical)
Interoperability	ONVIF Profile S , ONVIF Profile G , ONVIF Profile T , GB/T 28181

The table that follows shows the average typical optimized bitrate, in kbits/s, for different frame rates:

FPS	H.264	H.265
30	2740	2060
15	1690	1260
2	420	310
1	260	190

The average is for the highest resolution of the camera.

Actual bitrate may vary depending on the scene, picture settings, and encoder profile settings.

Mechanical

Drive Unit	Brushless, integral pan/tilt motor drive
Supported mounting orientation	Upright, Inverted, Canted
Pan Range	360° continuous rotation
Tilt Angle	290° (with or without illuminator)
Tilt Range	(With or without illuminator) Upright: -55° to +90°; Inverted: -95° to +55°; Canted: -80° to +65°
Variable Pan Speed	0.2°/second - 120°/second
Variable Tilt Speed	0.2°/second - 90°/second
Speed of Pre-positions	120°/second
Pre-position Accuracy	+/-0.05°
Proportional Pan / Tilt to Zoom	Yes
Audible Noise	<65 dB

Electrical

Input voltage	21-30 VAC, 50/60 Hz; High Power over Ethernet 56VDC nominal
Power Consumption (typical), without illuminator	40 W
Power Consumption (typical), with illuminator	70 W
Current consumption, 24 VAC	~3.15A
Current consumption, High PoE	~1.5A
Redundant configuration	Connect both a High PoE Midspan and a separate 24 VAC power source. If either power source fails, the camera automatically switches to the other power source.
Surge protection	Built-in surge protection for power, data, and network interfaces (Refer to the A&E Specifications for details.)

Communications / Software Control

Camera Setup/Control	Via web browser [Refer to the Release Letter of your camera's firmware for specific requirements.], Bosch Configuration Manager, Bosch Video Management System (BVMS), Video Security Client (VSC), Project Assistant, or support for third party software
Software Update	Network firmware upload

User Connections

Chassis ground	Ground wire with connector lug
Input voltage, without illuminator	RJ45 connector to 60 W High PoE Midspan (NPD-6001B) or 95 W High PoE Midspan (NPD-9501A or NPD-9501-E), or 21-30 VAC, 50/60 Hz; Female-to-female RJ45 coupler included
Input voltage, with illuminator	RJ45 connector to 95 W High PoE Midspan (NPD-9501A or NPD-9501-E)* or 21-30 VAC, 50/60 Hz; Female-to-female RJ45 coupler included
Power, Camera	24 VAC (power supply)
Video and Control	RJ45 100BASE-TX Ethernet

* Must purchase NPD-9501A or NPD-9501-E in order to use the High PoE solution.

Audio

Compression	G.711, AAC, and L16 (live and recording)
Signal-to-Noise Ratio (SNR)	Audio in: 47 dBA Audio out: 50 dBA
Mode	Two-way, full duplex audio communication
User connections	Line in: 130k ohm typical / 1.0Vrms, max Line out: 0.8Vrms at 2.4 ohm, typical

Environmental

The customer is responsible for making sure that the installation complies with the specified stresses that follow.

Note: Unit includes internal heater and fan.

Ingress Protection Rating/Standard	IEC 60529 IP66 / IP68 / Type 6P (dust and immersion) when installed on a MIC-DCA, or on a MIC wall mount with a MIC-SCA. IP67 (moisture and dust) with the IP67 Connector Kit (MIC-9K-IP67-5PK) on the connectors in the camera base. This kit is also required when using non-Bosch mounts.
------------------------------------	---

External Mechanical Impact (IK Code / Impact rating)	IEC 62262 IK10 (excluding glass window)
Operating temperature	-40 °C to +65 °C (-40 °F to +149 °F)
NEMA TS 2-2003 (R2008), para 2.1.5.1 using fig. 2.1 test profile	-34 °C to +74 °C (-30 °F to +165 °F) for 15 hours
Cold Start-up Temperature	-40 °C (-40 °F) (Requires 60-minute warm-up prior to PTZ operations.)
Storage temperature	-45 °C to +70 °C (-49 °F to +158 °F)
Humidity	0-100%
Wind Load	Sustained winds up to 161 kph (100 mph) An upright camera or an inverted camera with an illuminator will hold its position in gusts up to 241 kph (150 mph). A canted camera with an illuminator will hold its position in gusts up to 257 km/h (160 mph).
Effective Projected Area (EPA)	Camera + DCA: 0.0725 m ² (0.78 ft ²) Camera + DCA + illuminator: 0.0854 m ² (0.92 ft ²)
Vibration	IEC 60068-2-6: 10-150 Hz, 1.0G (0.5G on canted unit), 10m/s ² , 20 Sweeps NEMA TS-2 Section 2.2.8: 5-30 Hz, 0.5G MIL-STD-167-1A
Shock	IEC 60068-2-27, Test Ea: Shock, half sine impulse, 11 ms, 45 G (20G on canted unit), non-repetitive shocks (three shocks in each axis and in each direction) NEMA TS 2 Section 2.2.9 Shock (Impact) Test Half sine wave 11 ms, 10G
Power Service Transients	NEMA TS2 Section 2.2.7.2
Power Interruption	NEMA TS2 Section 2.2.10
MIL-STD-810 Military Standard Test Methods	MIL-STD-810-G, 501.5 High Temperature; MIL-STD-810-G, 502.5 Low Temperature; MIL-STD-810-G, 503.5 Temperature Shock; MIL-

	STD-810-G, 505.5 Solar Radiation; MIL-STD-810-G, 506.5 Rain; MIL-STD-810-G, 509.5 Salt Fog; MIL-STD-810-G, 510.5 Sand and Dust
Salt Mist Spray (Corrosion Test)	ISO 12944-6: C5-M (High); Aluminum Housing Components
Construction	
Dimensions (W x H x D)	Without illuminator accessory or sunshield: <i>Upright, Inverted:</i> 287.93 mm x 400.34 mm x 210.65 mm (11.34 in. x 15.76 in. x 8.29 in.) <i>Canted:</i> 260.25 mm (10.2 in.) x 374.5 mm (14.7 in.)
Weight	8.7 Kg (19.2 lb)
Window	Flat glass with defroster Defroster starts automatically at <= 5 °C (41 °F).
Construction Material	Anodized cast aluminum
Window Wiper	Integrated, long-life silicone wiper
Sunshield (to prevent sun load in hot climates)	Optional (sold separately)
Canting	On-site canting functionality
Color	White (RAL 9010)
Standard Finish	Corrosion-resistant, powder coat paint, sand finish

Ordering information

MIC-7604-Z12WR PTZ 8MP 12x enhanced white

Ruggedized PTZ camera; 4K UHD, 12x, optical image stabilization, defroster open camera platform
White (RAL 9010). Sand finish.
Order number **MIC-7604-Z12WR | F.01U.381.149 F.01U.386.567**

EWE-MICIIR-IW 12 mths wrty ext MIC IP str/dyn illum IR

12 months warranty extension
Order number **EWE-MICIIR-IW | F.01U.346.324**

EWE-VG4PS2-IW 12 mths wrty ext VG4-A-PSu2

12 months warranty extension
Order number **EWE-VG4PS2-IW | F.01U.346.348**

Accessories

MIC-ILW-400 Illuminator, white-IR light, white

Illuminator accessory for certain MIC IP cameras, IR Light (850 nm/940 nm) + White light LEDs
White (RAL 9010). Sand finish.
Order number **MIC-ILW-400 | F.01U.370.192**

NPD-6001B Midspan, 60W, single port, AC in

60 W indoor midspan for cameras without illuminators
Order number **NPD-6001B | F.01U.347.358 F.01U.392.458**

NPD-9501A Midspan, 95W, single port, AC in

95 W indoor PoE midspan for AUTODOME and MIC cameras
Order number **NPD-9501A | F.01U.286.250 F.01U.392.336**

NPD-9501-E Midspan 95W 1 port outdoor

95 W outdoor PoE midspan for AUTODOME and MIC cameras
Order number **NPD-9501-E | F.01U.365.279**

VG4-A-PSU1 PSU, 120VAC, for AUTODOME, MIC7000

Power supply for AUTODOME 7000, MIC IP cameras without illuminators.
120VAC in, 24VAC out
Order number **VG4-A-PSU1 | F.01U.009.667 F.01U.081.593 F.01U.261.377**

VG4-A-PSU2 Power supply, 230VAC, AUTODOME, MIC7000

Power supply for AUTODOME 7000, MIC IP cameras without illuminators.
230VAC in, 24VAC out
Order number **VG4-A-PSU2 | F.01U.081.604 F.01U.009.668 F.01U.096.639 F.01U.097.433 F.01U.261.378**

MIC-DCA-HW Deep conduit mount, two M25 holes, white

DCA mount for MIC7000 family and MIC IP fusion 9000i cameras. Aluminum. Two M25 holes for conduit/cable glands.
White (RAL 9010) color.
Order number **MIC-DCA-HW | F.01U.286.245**

MIC-DCA-HWA Deep conduit mount, M25 holes, white

DCA mount for MIC7000 and MIC IP fusion 9000i cameras. Aluminum. Two M25 holes for conduit/cable glands. Includes an conduit adapter (male M25 to female 3/4" NPT). Available in specific regions only.
White (RAL 9010) color.
Order number **MIC-DCA-HWA | F.01U.303.167**

MIC-WMB-WD Wall mount bracket, white

Wall mount bracket, white sand finish (RAL9010)
Order number **MIC-WMB-WD | F.01U.143.156**

MIC-SCA-WD Shallow conduit adapter, white sand

Shallow conduit adapter for a MIC-WMB, a MIC-PMB, or a MIC-SPR mount, white sand finish (RAL9010)
Order number **MIC-SCA-WD | F.01U.143.154**

MIC-PMB Pole mount bracket

Pole mount bracket (includes 2 x 455 mm stainless steel banding straps for pole diameters 75 to 145 mm)
Order number **MIC-PMB | F.01U.087.283**

MIC-CMB-WD Corner mount bracket, white

Corner mount bracket, white sand finish (RAL9010)

Order number **MIC-CMB-WD | F.01U.143.159**

MIC-SPR-WD Wall mount spreader plate, white sand

Aluminum spreader plate suitable for brickwork surface mounting, white sand finish (RAL9010)

Order number **MIC-SPR-WD | F.01U.143.163**

MIC-M25XNPT34 Adapter, M25 to 3/4" NPT, stainless steel

Stainless Steel M25 to 3/4" NPT thread adapter

Order number **MIC-M25XNPT34 | F.01U.301.975**

MIC-WKT-IR Washer kit, MIC IR

Washer kit for MIC IP starlight 7000i and MIC IP fusion 9000i camera models

Washer kit for analog infrared MIC camera models

Order number **MIC-WKT-IR | F.01U.087.255**

MIC-IP67-5PK Connector kit, IP67, 5pcs

5-pack weather protection kit for MIC7000 cameras.

Provides an IP67-rated barrier against dust or moisture.

Recommended when MIC camera is mounted directly to installation surface (instead of onto a MIC-DCA or MIC wall mount).

Order number **MIC-IP67-5PK | F.01U.294.750**

MIC-7100I-SNSHLD-W Sunshield for MIC 7100i white

Sunshield for MIC IP ultra 7100i camera models

Order number **MIC-7100I-SNSHLD-W | F.01U.353.591**

Services**EWE-MIC7IF-IW 12 mths full wrty ext MIC IP 7000i**

12 months warranty extension

Order number **EWE-MIC7IF-IW | F.01U.382.951**

Represented by:

Europe, Middle East, Africa:
Bosch Security Systems B.V.
P.O. Box 80002
5600 JB Eindhoven, The Netherlands
Phone: + 31 40 2577 284
emea.securitysystems@bosch.com
emea.boschsecurity.com

Germany:
Bosch Sicherheitssysteme GmbH
Robert-Bosch-Ring 5
85630 Grasbrunn
Germany
www.boschsecurity.com

North America:
Bosch Security Systems, LLC
130 Perinton Parkway
Fairport, New York, 14450, USA
Phone: +1 800 289 0096
Fax: +1 585 223 9180
onlinehelp@us.bosch.com
www.boschsecurity.us

Asia-Pacific:
Robert Bosch (SEA) Pte Ltd, Security Systems
11 Bishan Street 21
Singapore 573943
Phone: +65 6571 2808
Fax: +65 6571 2699
apr.securitysystems@bosch.com
www.boschsecurity.asia