

FPMCPU



FRONT-PLATE CPU MODULE AND REPEATER

PREVIDIA | MAX



Main control unit for Previdia Max control panels.

To be connected to the CAN DRIVE bar inside the metal cabinets and equipped with a 7" graphic colour touchscreen. Each FPMCPU unit contains two CPUs: a main CPU and a second emergency CPU capable of taking over control of the basic system functions in the event of fault on the main CPU, as required by EN54 part 2. For complete redundancy of all the configured functions and logics, it is necessary to install an FPMCPU module which must be configured as the system backup unit.

The FPMCPU front-plate module has three operating modes:

- main unit of the control panel
- backup unit
- remote repeater user-interface

Mounts to the frontplate of the Previdia Max control panel and, if housed in the upper opening, connects to the CAN DRIVE bar. However, if housed in the lower opening, it connects to the FPM module in the upper opening. Each Previdia Max control panel can manage 2 FPMCPU modules (one main and one backup), or up to 14 FPMCPU modules if set as repeaters.

HARDWARE CHARACTERISTICS

- Double CPUs, a main CPU and a emergency backup that will take over in the event of fault on the main CPU.
- 7" touch screen, 65000 colours
- 6 status LEDs
- 6 LED and function buttons
- LED and button for multiple alarm management
- Scandinavian key to access level 2 (EN54 part 2)
- Ethernet port
- RS232 port
- Mini USB port
- RS485 port for the connection of up to 14 repeater panels
- RS485 port for ModBus RTU
- Connector for the connection to other frontplate module
- Housing for µSD card

TECHNICAL SPECIFICATIONS

- Customization of user interface, icons, buttons etc.
- Connection over RS485 or TCP/IP (if set as repeater)
- Possibility to operate in three different modes: main control panel unit, backup unit, remote repeater user-interface
- Event visualization filter
- Customization of event priority and visualization
- Power voltage: 19-30Vdc
- Consumption @ 27.6V: stand-by 120mA, max. 140mA
- Maximum current on RS485-REPEATER @ 27.6V 1A
- Maximum current on RS485-BMS @27.6V 1A

DIMENSIONS

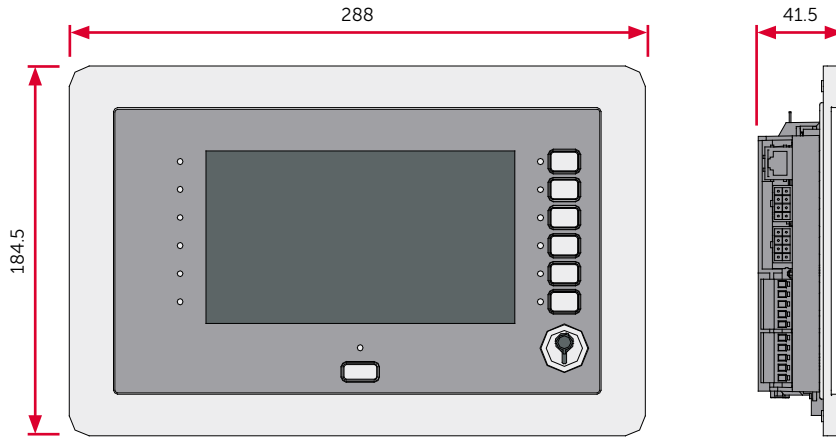

INSTALLATION

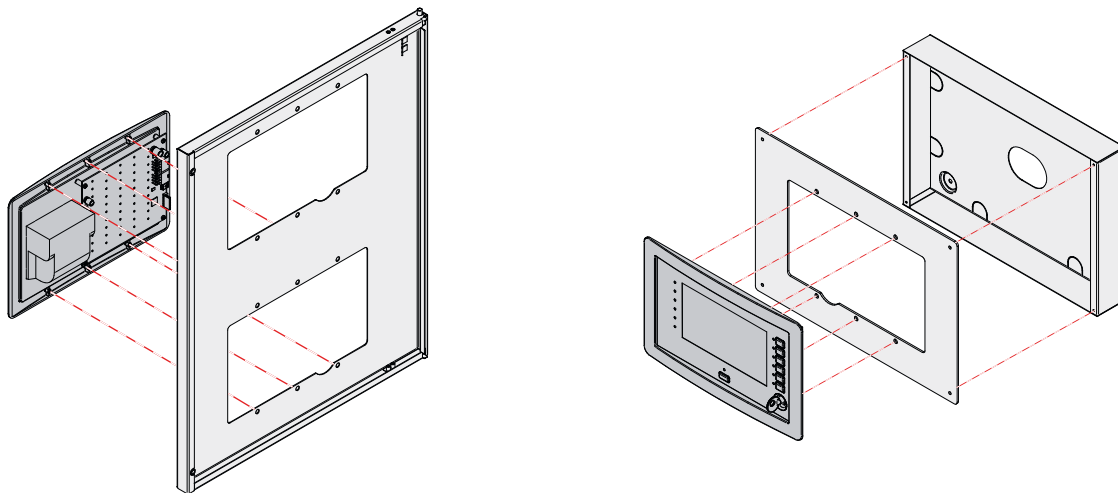

IN THE PACKAGE

- Package dimensions: 32.5 x 62 x 25 cm
- Weight: 900g

ORDER CODES

FPMCPU main unit module

PRREP enclosure for mounting FPMCPU module as remote repeater