

Intelligent Base Mounted Flame Detectors



Product overview

Product	Intelligent Base Mounted UV Flame Detector
Part No.	55000-022
Product	Intelligent Base Mounted UV/IR Flame Detector
Part No.	55000-023
Product	Triple IR Flame Detector
Part No.	55000-024
Product	Flame detector test unit
Part No.	29600-226
Product	Adjustable mounting bracket including deckhead mounting box
Part No.	29600-458

Technical Data

All data is supplied subject to change without notice. Specifications are typical at 24V, 73°F and 50% RH unless otherwise stated.

	UV	UV/Dual IR	Triple IR
Supply voltage	17 - 28 V dc	17 - 28 V dc	17 - 28 V dc
Protocol peak to peak	5 - 9 V	5 - 9 V	5 - 9 V
Quiescent current	2.3 mA	2.8 mA	2.5 mA
Alarm current	4.2 mA	4.2 mA	4.2 mA
Surge current	9 mA (peak) for 110 ms	9 mA (peak) for 85 ms	9 mA (peak) for 85 ms
Maximum power-up time	4 seconds	4 seconds	4 seconds
Remote output characteristics	Connects to positive line through 4.5 kΩ (5 mA maximum)	Connects to positive line through 4.5 kΩ (5 mA maximum)	Connects to positive line through 4.5 kΩ (5 mA maximum)
Operating range	0.1 m ² n-heptane at 25 m	0.1 m ² n-heptane at 25 m	0.1 m ² n-heptane at 25 m
Sensitivity	Class 1 or 3, EN 54-10	Class 1 or 3, EN 54-10	Class 1 or 3, EN 54-10
Field of view	90° cone	90° cone	90° cone
Spectral response	UV 185 to 260 nm	UV 185 to 260 nm, IR 0.75 to 2.7 μm	0.75 to 2.7 μm
Operating temperature (no condensing or icing)	-40°C to +70°C	-40°C to +70°C	-40°C to +70°C
Storage temperature	-40°C to +85°C	-40°C to +70°C	-40°C to +70°C
Relative humidity	95% non-condensing	95% non-condensing	95% non-condensing
IP rating	IP66	IP66	IP66
Dimensions	100 mm x 40 mm detector only 100 mm x 48 mm detector and base	100 mm x 40 mm detector only 100 mm x 48 mm detector and base	100 mm x 40 mm detector only 100 mm x 48 mm detector and base
Weight	150 g - detector only 210 g - detector and base	150 g - detector only 210 g - detector and base	150 g - detector only 210 g - detector and base
Materials:			
Housing	White polycarbonate, V-0 rated to UL94	White polycarbonate, V-0 rated to UL94	White polycarbonate, V-0 rated to UL94
Sensing window	2 mm Quartz	2 mm Quartz	2 mm Float glass
Terminals	Nickel plated stainless steel	Nickel plated stainless steel	Nickel plated stainless steel
Isolator count:			
20D	7	7	7
20i	20	20	20



A HALMA COMPANY

© Apollo Fire Detectors Limited 2017



Intelligent Base Mounted Flame Detectors

Product information

The Intelligent Base Mounted Flame Detectors are designed to protect areas where open fires may be present.

Intelligent Base Mounted UV Flame Detector

The Intelligent UV Base Mounted Flame Detector is sensitive to ultraviolet (UV) radiation emitted by flames during combustion. Since it requires only UV radiation the detector responds even to stationary flames with no flicker such as cigarette lighters and blue gas flames.

The detector is set to respond to UV radiation (185 - 260 nm) emitted by almost all flames including those invisible to the naked eye, e.g. hydrogen fires.

The detector has a single UV sensor with a narrow spectral response in order to discriminate between flames and most spurious sources of radiation and is designed for use in internal fully enclosed areas.



CAUTION: The detector will also detect electrical discharges from lightning or arc welding.

Intelligent Base Mounted UV/Dual IR Flame Detector

The Intelligent Base Mounted UV/Dual IR Flame Detector is sensitive to UV and low-frequency, flickering infra-red (IR) radiation emitted by flames during combustion. Since it requires both UV and IR radiation the detector can operate in applications where a basic single UV or single IR detector would be inappropriate. The detector is set to respond to UV (185 - 260 nm) and low-frequency, flickering IR (0.75 - 2.7 μm) radiation at 1 - 15 Hz in order to detect all flickering flames, including those invisible to the naked eye, e.g. hydrogen fires. The detector has one UV and two IR sensors responding to different wavelengths in order to discriminate between flames and spurious sources of radiation. False alarms due to electrical discharges or arc welding and flickering sunlight are minimised by combining the UV/IR signals.

Triple IR

The detector is sensitive to low frequency, flickering IR radiation emitted by flames during combustion. Since it responds to flickering radiation the detector can operate even if the lens is contaminated by a layer of oil, dust water-vapour or ice. The detector is set to respond to low-frequency radiation at 1 - 15 Hz (0.75 - 2.7 μm) in order to detect all flickering flames, including those invisible to the naked eye, e.g. hydrogen fires. The detector has three IR sensors that respond to different IR wavelengths in order to discriminate between flames and spurious sources of radiation. False alarms due to factors such as flickering sunlight are avoided by a combination of filters and signal processing techniques.

Applications for Intelligent Base Mounted Flame Detectors*

UV

UV detectors are used when detection is required to be unaffected by convection currents, draughts or winds. These include engine rooms in ships, factories affected by draughts or wind and warehouses.

They are fast reacting and respond to a flame more than 25 m away. The UV flame detector is affected by arc welding, electrical sparks, lightning, nuclear radiation and UV light sources. For applications where these phenomena are present a UV flame detector should not be used.

UV/Dual IR

These detectors are not affected by any of the sources mentioned above. They are suitable for use in aircraft hangars, generator rooms (diesel and gas turbines) and paint works.

Triple IR

These detectors are also fast reacting but is also tolerant of fumes, vapours, steam, dust and mist, whilst being unaffected by the phenomena listed above. It may, however, be affected by modulated IR radiation. Triple IR flame detectors are used in waste handling, colour printing and paper manufacturing applications.

* For a full list of applications for Apollo Intelligent Base Mounted Flame Detectors, please refer to PP2409, available on request or from www.apollo-fire.co.uk

Protocol compatibility

The detectors operate with control equipment using the XP95 or Discovery digital protocol and are CoreProtocol® ready.

Protocol usage

Output Bits	
2	LED
1	Test
0	Remote LED
Interrupt	No
Analogue value	
Quiescent	25
Alarm	55 - 64
Fault	4
Input Bits	
2	LED confirmed
1	Test confirmed
0	Remote LED confirmed
Flag settings	
XP95 flag	Yes
Alarm flag	Yes

Electrical considerations

The Intelligent Base Mounted Flame Detectors are loop-powered and require no external supply. A remote LED alarm indication may be connected to the flame detector.

Intelligent Base Mounted Flame Detectors

The field of view for the Intelligent Base Mounted Flame Detectors is shown in Figure 1. The illustration also includes information on the size of fire detectable at various distances.

The flame detectors can also be ceiling mounted positioned above the anticipated flame source or at the centre of the area to be protected, perpendicular to the floor below. If the detector cannot see the whole of the area to be protected, one or more additional detectors may be required. Figure 2 shows the angle of view to help you establish the detectors performance. The area of detection is dependent upon the detectors height above the likely source of flame.

The detectors have a 90° conical field of view or 45° either side of the viewing axis centre line. The maximum ceiling height is 20 m. If the detector is perpendicular to the floor and at a height of 10 m, the detector will view a circular floor area below with a 10 m radius (20 m diameter circle).

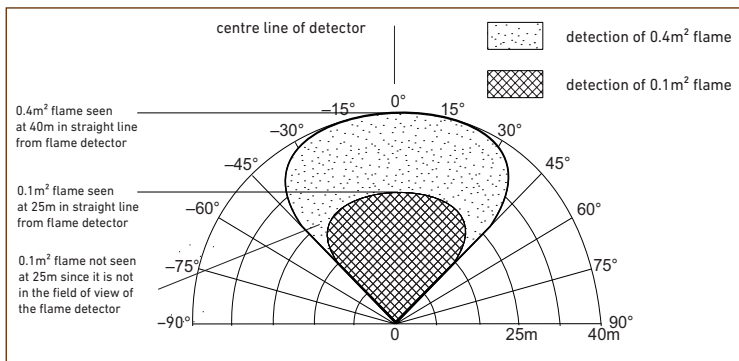

Figure 1: Field of view

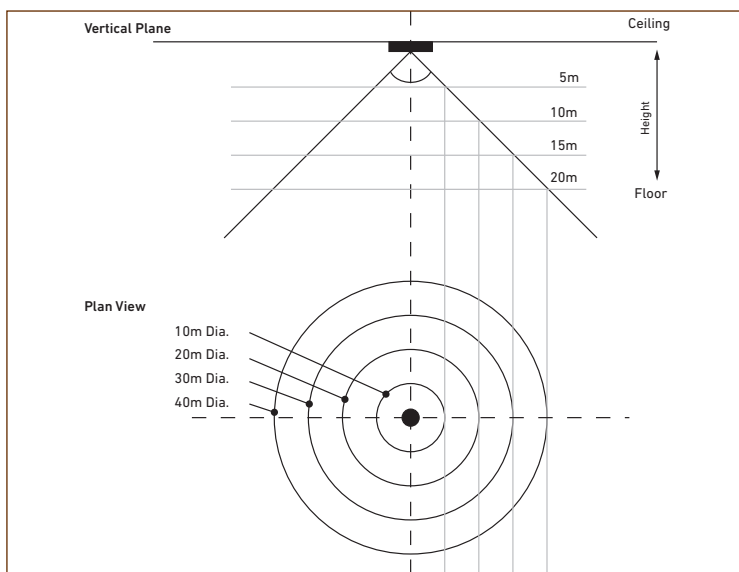

Figure 2: Ceiling mounting measurements